



POOL OWNER'S GUIDE TO POOL COVER OPERATION & SAFETY



SAFETY INSTRUCTIONS	3
MANUALLY SECURING YOUR COVER	4
SYSTEM GLOSSARY	5
CARE & MAINTENANCE	6
DIAGNOSTICS/SERVICE	7
FREQUENTLY ASKED QUESTIONS	7
SYSTEM CONTROLLER INSTRUCTIONS	
POWERTOUCH™	8
KEY SWITCH	9
LIMITED WARRANTY	
MECHANICAL AND ELECTRICAL	10
COVER AND FABRIC	11
SYSTEM INFORMATION & HISTORY	12



WARNING



DO NOT ATTEMPT TO CONNECT, OR DISCONNECT, THE CONTROL UNIT OR MOTOR HARNESS WHILE SUPPLY POWER IS ON. DOING SO CAN IRREVERSIBLY DAMAGE CONTROLLER AND COVER MOTOR, AND POTENTIALLY CAUSE SERIOUS INJURY OR DEATH.

READ AND FOLLOW ALL INSTRUCTIONS

WARNING: To reduce the risk of injury, whenever possible, cover should only be **operated by an adult or pool owner**. Do not permit children to use this product unless closely supervised at all times.

To reduce the risk of electric shock, connect the local common-bonding grid and all other metal within 3m to the equipment bonding lugs with solid copper conductors not less than No. 6 AWG

- ▲ **NEVER LEAVE COVER PARTIALLY OPENED.** Entrapment is possible.
- ▲ **ENSURE ALL SWIMMERS AND OBJECTS ARE OUT OF THE POOL/SPA** before closing cover.
- ▲ **KEEP CHILDREN AWAY FROM COVER.** Children and objects are not visible underneath the cover.
- ▲ **DO NOT WALK ON THE COVER** except for in emergency circumstances.
- ▲ **PREPARE PUMP FOR PROPER USE; LEAVE PUMP ON THE COVER** when cover is closed.
- ▲ **ALWAYS PUMP WATER OFF THE COVER** to avoid drowning risk.
- ▲ **STORE ALL ELECTRICAL CORDS AND SUBMERSIBLE PUMP AWAY FROM SWIMMING AREA** while pool is in use.
- ▲ **CHECK COVER FREQUENTLY FOR SIGNS OF DETERIORATION.**

SAVE THESE INSTRUCTIONS

MANUALLY SECURING YOUR COVER

! IMPORTANT !

**NEVER LEAVE POOL UNCOVERED WITHOUT ADULT SUPERVISION
TO PREVENT A DROWNING HAZARD, THE AUTOMATIC COVER CAN BE CLOSED MANUALLY
IF POOL COVER CONTROL SYSTEM BECOMES INOPERABLE WHILE POOL COVER IS OPEN**

IMPORTANT NOTE

- Instructions for AUTOMATIC POOL COVERS, INC. systems.
 - Complete steps 1 - 8 for an AutoGuard™ cover system
 - Complete steps 5 - 8 for a Spa cover system
1. Turn off power supply to cover system
 2. Remove lid or housing cover
 - located at end of pool where cover rolls in, on right or left side (allows access to cover system mechanical components).
 3. Locate motor coupler assembly (attaches motor to cover mechanism)
Coupler may have to be rotated with channel-lock pliers to access the bolt heads.
 4. Remove two coupler bolts
 - Use 9/16" wrench (socket wrench with extension works best) to remove two coupler bolts (eliminates resistance on the cover from idle motor).
 5. Locate ropes and rope reel
 6. Pull ropes upward incrementally, unwinding the reel until the ropes are at their end
 7. Unfasten ropes from both reels (freeing ropes from reels).
 8. Establish a good grip in same spot on each rope and pull (Cover should move)
 - Keep tension on both ropes (keeping cover straight)
 - Reset grip before each pull if necessary
 - Move cover a few feet with each pull
 - Continue until cover is closed

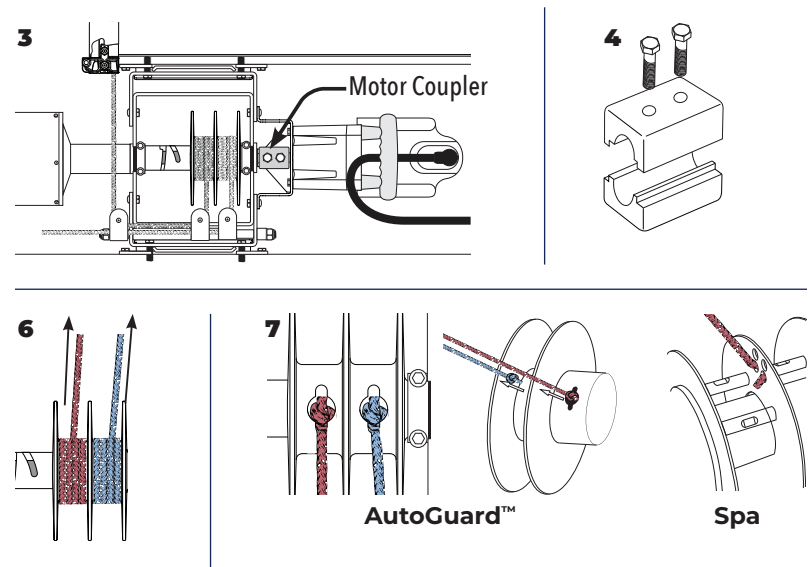

**Items colored for identification only. Actual product may vary.*

For assistance with this procedure, contact your cover service company or Automatic Pool Covers, Inc. Technical Support (800) 878-5789.

SYSTEM COMPONENTS

- 1 POWERTOUCH™ TOUCHPAD CONTROLLER†**
- 2 KEY SWITCH CONTROLLER†**
- 3 MOTOR**
Drives the system
- 4 MECHANISM END**
Motor end of cover system
- 5 TUBE**
Where the cover rolls into
- 6 HOUSING**
Houses mechanism & cover
- 7 OPPOSITE END**
Non-motor end
- 8 ROPE GUIDE***
Transitions rope from track to mechanism
- 9 TRACK**
Secures cover on pool side
- 10 PULLEY CASTING***
Rope turns at far end
- 11 ROPE**
Connected to cover;
runs inside the track
- 12 GLIDER & BRACKET***
Connects lead edge to
under track **B**
- 13 LEAD EDGE**
Front edge of pool cover
- 14 CARRIAGE & BRACKET***
Connects lead edge to
tracks **A** and webbing **15**
- 15 WEBBING**
Reinforced material
connected to cover edge **C**
- 16 COVER**
Vinyl that protects pool

SYSTEM LAYOUT

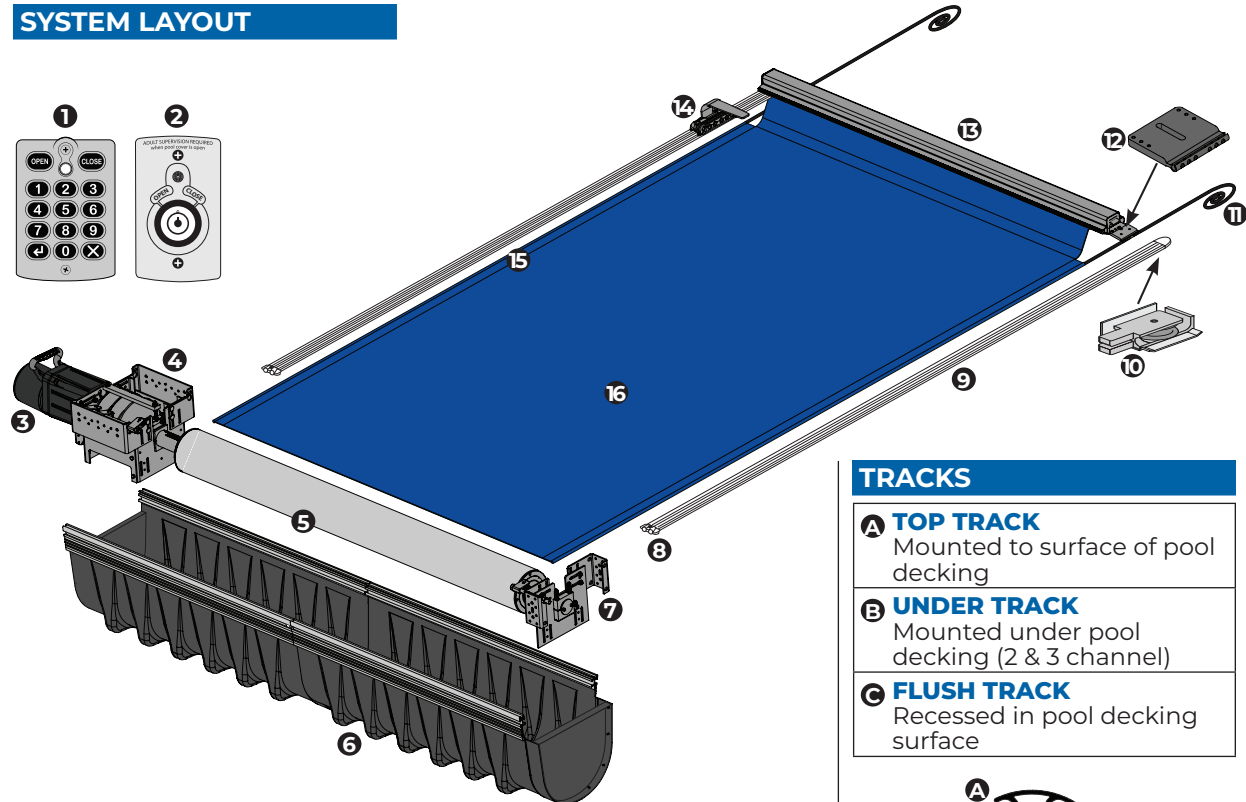

Pool Cover Pump*
*Included pool cover pump model may vary.

TRACKS

- A TOP TRACK**
Mounted to surface of pool decking
- B UNDER TRACK**
Mounted under pool decking (2 & 3 channel)
- C FLUSH TRACK**
Recessed in pool decking surface

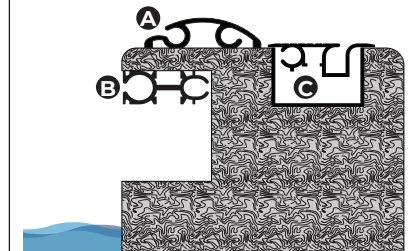

THIS ILLUSTRATION SHOWS THE BASIC LAYOUT OF MAJOR COMPONENTS OF THE SYSTEM AND THEIR FUNCTION. YOUR SYSTEM MAY VARY SLIGHTLY.

*Part design appearance may differ from illustration. †Your system has either controller **1** or **2**.

CARE & MAINTENANCE

POOL COVER

- Remove all debris and water routinely.
- Do not operate your cover in temperatures below 40° F.
- Do not operate your cover if the water level is below the skimmer. (Will cause strain in cover and potential damage to the system.)
- Winterizing: water level should not be lower than 2" below the skimmer. Slack in cover will accommodate winter water level.
- Ladders must be raised or removed before closing the cover.
- Leave cover open up to 60 minutes after adding pool water chemicals to allow dissipation.

Responsible adult should attentively supervise the pool.

VINYL POOL COVER FABRIC

- Fabric will wear over time due to chemicals, age, heat and UV-rays, causing it to become brittle. A weakened fabric may compromise safety and should be replaced.
- Inspect fabric for holes. If necessary, call your pool service company for an easy-to-use patch kit.
- Inspect webbing (material that moves through the tracks). Tearing or fraying will compromise the strength of the pool cover.

TRACKS

- Inspect deck/coping screws (if applicable). Loosened screws should be tightened with a #3 Phillips-head screwdriver.
- Remove potential debris/build-up twice per year (Spring/Autumn) by using a hose and high-pressure nozzle to spray water into the tracks. Begin at the motor-end of the pool cover system, spraying continually to the end until the water appears clear.

MECHANISM

- Clean the recessed box for the cover mechanism once per year minimally. Leaves or debris inside the box can be deposited into your pool water while operating your cover system.
- An opening in the recessed box allows drainage, preventing undue wear. Check the recessed box for standing water, additional drainage may be necessary.
- Shut off power to the cover system when pool is closed seasonally.

ROPES

- Inspect pulley system ropes. Ropes with fraying or unusual wear should be replaced by your pool cover service technician before possible breakage.
- Ropes and webbing do not require grease or lubrication. Adding certain petroleum-based products may damage your pool components or be harmful to your health.

SUBMERSIBLE PUMP

- Pump must be plugged into a G.F.C.I outlet only.
- Cover pump must be UL/ULC approved and meet ASTM safety standard specifications
- Pump shall be placed where water tends to pool on the cover
- Inspect the pump and cord periodically. Frayed cords can allow water into the housing and cause malfunction.
- Keep the pump clear of debris..

WHOLE-SYSTEM MAINTENANCE SHOULD BE PERFORMED BY A TRAINED SERVICE TECHNICIAN ANNUALLY OR BI-ANNUALLY.

REGULAR MAINTENANCE INCLUDES CLEANING THE RECESSED BOX, OVERALL SYSTEM TUNE-UP AND COMPLETE SAFETY CHECK.

DIAGNOSTICS/SERVICE & FREQUENTLY ASKED QUESTIONS

COVER DOES NOT OPEN/CLOSE WHEN I ACTIVATE THE CONTROLLER

Operate the controller while a partner stands by the pool cover box. If your partner does not hear the motor running, the issue may be occurring within other system components.

WATER APPEARS ON MY COVER WHEN IT HAS NOT RAINED IN DAYS

This may be an indication of a hole in your pool cover. Contact your pool cover service company for a patch kit to easily repair.

COVER STOPS HALF WAY CLOSED/OPENED

1. Clean the tracks with water as this might be caused by dirt or debris inside the tracks.
2. Lift the lid. If the rope appears to be tangled, call for service or carefully attempt to untangle the ropes.
3. Pump any water off of the cover. If the issue continues, a trained technician may need to perform a torque adjustment.

CONTROLLER INDICATOR LIGHT IS BLINKING RED

Cover has stopped under stress. Possible causes: Too much water on the cover (use pump to remove water), debris in the tracks (remove debris and/or clean with water). If red light continues to blink, cover operation may be crooked or torque level is too low (call for service). Contact Automatic Pool Covers, Inc. technical support at (800) 878-5789, or your local service provider.

COVER IS COMPLETELY OPEN AND WILL NOT CLOSE

Check your electrical service or ensure you are using the correct code. This indicates lack of power to your pool cover system.

SUBMERSIBLE COVER PUMP IS NOT PUMPING WATER

Check your pump owner's manual for troubleshooting tips. The automatic shut-off may be malfunctioning.

NOTICE: AN INOPERABLE COVER IN THE OPEN POSITION POSES A SAFETY RISK. IF YOU CANNOT DIAGNOSE THE ISSUE PREVENTING YOUR COVER FROM FULLY CLOSING, CONTACT AUTOMATIC POOL COVERS, INC. TECHNICAL SUPPORT AT (800) 878-5789 OR YOUR LOCAL COVER SERVICE PROVIDER FOR ASSISTANCE.

CAN I WALK ON THE COVER?

The cover is capable of supporting thousands of pounds in proper operating condition, however, it is NOT recommended to walk on the cover, with exception of emergency circumstances only.

THERE SEEMS TO BE A LOT OF SLACK IN THE COVER, IS IT TOO BIG?

No. The fabric is manufactured to include extra material, allowing for variance in water level. Wrinkled material will become smooth over water surface.

CAN THE COVER BE OPENED/CLOSED MANUALLY?

Yes. Refer to the "Manually Securing Your Cover" section of this manual, or contact your automatic pool cover service company.

IF MY POOL LEAKS, OR I DRAIN MY POOL/SPA, SHOULD I CLOSE THE COVER?

No. The automatic pool cover is ineffective when the water level is more than 6 inches below the skimmer. Closing the cover without support from the water surface may cause damage to the cover system. A pool containing any amount of water can be a hazard.

THE COVER IS CROOKED WHEN OPENING/CLOSING, WHAT SHOULD I DO?

If the cover opens or closes more than 2 inches off of its normal position, contact your automatic pool cover service provider for an adjustment by a trained technician.

SHOULD I LEAVE THE COVER PUMP ON THE COVER AT ALL TIMES?

Yes. The pool cover pump will automatically pump water off of the cover, preventing drowning risks and damage to the pool cover system. The only exception is during severe winter weather conditions, when the pump should be removed and placed in a warm location. When ice and snow begin to melt, place the pump back on the pool cover.

IS A "POPPING SOUND" NORMAL WHEN I OPEN OR CLOSE THE COVER?

Yes. The popping sound is caused as the ropes pass through the pulleys, onto the rope reel, occurs when the rope "snaps" down into a low spot.

SYSTEM CONTROLLER INSTRUCTIONS - POWERTOUCTM

IMPORTANT PRIOR TO OPERATING COVER

- Ensure that you are familiar with all of the safety instructions
- READ INSTRUCTIONS prior to OPERATING COVER
- Ensure swimmers are not in the pool/SPA during operation
- Remove cover pump
- Clear obstructions (towels, ladders, toys, pool furniture, etc.)
- Remove water or debris (leaves, etc.) with cover pump or pool brush



LOCATION INDICATORS

- A** OPEN COVER
- B** CLOSE COVER
- C** INDICATOR LIGHT
- D** NUMBER KEYS 0-9
- E** ENTER
- F** CANCEL/EXIT

INDICATOR LIGHT **C**

- SOLID GREEN** System ready
- SOLID RED** Enter new code
- FLASHING GREEN** System in motion
- FLASHING RED** Obstruction or error

CHANGING YOUR CODE

To change default (1 2 3 4) or custom code:

1. Press and hold ENTER ✓ until Indicator Light **C** glows SOLID RED
2. Enter new four-digit code
3. SOLID RED Indicator Light **C** turns off when new code is accepted

Controller is ready for normal use

⚠ REVIEW IMPORTANT! INFORMATION ON LEFT

1. Type your 4 digit code on the Touchpad **D** then press and release ✓ (**E**).
NOTE: If the code is entered correctly, the light will illuminate solid green. If entered incorrectly, the light will blink red 2 times indicating the code has not been accepted.

OPENING THE COVER

1. Press and hold the **OPEN (A)** button
Indicator Light **C** will flash green while cover is moving
2. Release the **OPEN (A)** button when cover is fully opens

⚠ IMPORTANT! VERIFY THAT COVER IS FULLY OPEN

3. The Indicator Light **C** will turn solid green.
4. Turn off the controller by letting the controller rest for 20 seconds, or pressing the **X** button

CLOSING THE COVER

1. Press and hold the **CLOSE (B)** button
Indicator Light **C** FLASHES green while cover is moving
 2. Release the **CLOSE (B)** button when the cover is fully closed
- ## ⚠ IMPORTANT! VERIFY COVER IS FULLY CLOSED
3. The Indicator Light **C** will turn solid green
 4. Turn off the controller by letting the controller rest for 20 seconds, or pressing the **X** button
 5. Place cover pump on pool cover, and plug into a G.F.C.I. electrical outlet

SYSTEM CONTROLLER INSTRUCTIONS - KEY SWITCH

*IMPORTANT! PRIOR TO OPERATING COVER

- Ensure that you are familiar with all of the safety instructions
- READ INSTRUCTIONS prior to OPERATING COVER
- Ensure swimmers are not in the pool/SPA during operation
- Remove cover pump
- Clear obstructions (towels, ladders, toys, pool furniture, etc.)
- Remove water or debris (leaves, etc.) with cover pump or pool brush



LOCATION INDICATORS

- A** INDICATOR LIGHT
- B** OPEN COVER
- C** CLOSE COVER
- D** KEY

INDICATOR LIGHT **A**

SOLID GREEN System ready

FLASHING GREEN System in motion

SOLID RED Cover is open/closed

FLASHING RED Obstruction or error

❗ REVIEW IMPORTANT! INFORMATION ON LEFT.

- Be sure the key switch light is **SOLID GREEN**, indicating there is power to the cover system
- If the light begins to **FLASH RED** during the **OPEN/CLOSE** procedure, the cover has stopped due to a strain on the motor. Release key and troubleshoot. Clear any obstructions. Reverse cover to the close direction for a few feet and then switch direction back to open. If light continues to **FLASH RED**, call for service.

OPENING THE COVER

1. Insert key **D**, turn **LEFT** to **OPEN (B)** cover.
2. The Indicator Light **A** will **FLASH GREEN** and cover will begin to move.
3. Continue holding key in **OPEN** position during opening process
4. Indicator Light becomes **SOLID RED** when cover is completely **OPEN**
5. When the key is released, the Indicator Light will turn **SOLID GREEN**

❗ IMPORTANT! VERIFY COVER IS FULLY OPEN

CLOSING THE COVER

1. Insert key **D** turn **RIGHT** to **CLOSE (C)** cover.
2. Indicator Light **A** will **FLASH GREEN**, cover will begin to move.
3. Continue holding key in **CLOSE** position during closing process
4. Indicator Light becomes **SOLID RED** when cover is completely **CLOSED**
5. When the key is released, the Indicator Light will turn **SOLID GREEN**

❗ IMPORTANT! VERIFY COVER IS FULLY CLOSED

LIMITED WARRANTY

MECHANICAL AND ELECTRICAL

Automatic Pool Covers, Inc. warrants the Mechanical and Electrical components to be free from defects in material or workmanship which results in failure of the component and/or an inoperable Cover System.

MECHANICAL COMPONENTS TERMS AND CONDITIONS:

The Mechanical Components Limited Warranty Period is ten (10) years or one-hundred-twenty (120) months from the shipment date of the Mechanical Components from Automatic Pool Covers, Inc. Automatic Pool Covers, Inc. will replace or repair the Mechanical Components and include return shipping costs from Automatic Pool Covers, Inc. during the Limited Warranty Period.

The Mechanical Components Limited Warranty does not include pulleys, guides, lead edge gliders or custom items.

ELECTRICAL COMPONENTS TERMS AND CONDITIONS:

The Electrical Components Limited Warranty Period is three (3) years or thirty-six (36) months from the shipment date of the Electrical Components from Automatic Pool Covers, Inc. Automatic Pool Covers, Inc. reserves the right to replace or repair the Electrical Components and include return shipping costs from Automatic Pool Covers, Inc. during the Limited Warranty Period.

MECHANICAL AND ELECTRICAL COMPONENTS LIMITED WARRANTY CONDITIONS:

Components are treated as individual parts of the System, and they are each covered individually, not wholly.

The Limited Warranty does not include any travel or labor costs for replacement or repair of warranted parts from Automatic Pool Covers, Inc. to the Pool Cover Dealer, Distributor or Pool Cover Owner.

- The Limited Warranty does not cover shipping costs of Components to Automatic Pool Covers, Inc.
- The Limited Warranty does not cover incidental or consequential damages.
- The Limited Warranty is not valid if full payment has not been received by Automatic Pool Covers, Inc. in accordance with the original terms and conditions of sale prior to warranty claim.
- The Limited Warranty does not cover the following: Acts of God such as storm or flood, snow damage, operation of the Cover System with frozen water and/or in temperatures below forty (40°) degrees Fahrenheit, inadequate pool water level, or due to user abuse, improper installation, improper chemical balance, or failure to comply completely with the Manufacturer's Installation and Owner's Manual guidance.

All Limited Warranty Claims must be pre-authorized by Automatic Pool Covers, Inc. and Components are required to be returned to Automatic Pool Covers, Inc. for warranty determination. Replacement Components will carry the balance of the original warranty.

Automatic Pool Covers, Inc. warrants the Cover Fabric material free from defects due to excessive shrinkage or deterioration whereby the Fabric is unable to prevent a volume of pool water from penetrating through the bottom of the Fabric or which results in an inoperable Cover System.

The Cover Fabric Material Limited Warranty Period is five (5) years or sixty (60) months from the ship date of the Fabric from Automatic Pool Covers, Inc. to the Pool Cover Dealer or Distributor. Automatic Pool Covers, Inc. reserves the right to replace or repair the Fabric Material and include return shipping costs from Automatic Pool Covers, Inc. during the first three (3) years or thirty-six (36) months of operation if defects in the Fabric are due to excessive shrinkage or deterioration of the Fabric where the Fabric is unable to prevent a volume of pool water from penetrating up through the bottom of the Fabric and which results in an inoperable Cover System.

Automatic Pool Covers, Inc. will replace or repair the Fabric Material in the fourth (4th) through fifth (5th) year, or thirty-seventh (37th) month through the sixtieth (60th) month of the Warranty Period, on a replacement cost basis including return shipping costs from Automatic Pool Covers, Inc. The material replacement cost will be reduced by one-sixtieth (1/60th) per month for each remaining month of warranty. The automatic or manual pool Cover System must have been installed and operated in accordance with the Manufacturer's Installation and Owner's Manual in order to qualify for a warranty claim.

FABRIC LIMITED WARRANTY CONDITIONS:

Vinyl, ropes and hybrid-webbing are treated as individual parts of the Fabric, while all are covered under the Limited Warranty they are each covered individually, not wholly.

- The Limited Warranty does not include any travel or labor costs for replacement or repair of warranted parts from Automatic Pool Covers, Inc. to the Pool Cover Dealer, Distributor or Pool Cover Owner.
- The Limited Warranty does not cover shipping costs to Automatic Pool Covers, Inc.
- The Limited Warranty does not cover incidental or consequential damages.
- The Limited Warranty is not valid if full payment has not been received by Automatic Pool Covers, Inc. in accordance with the original terms and conditions of sale prior to warranty claim.
- The Limited Warranty does not cover the following: Acts of God such as storm or flood, snow damage, operation of the Cover System with frozen water and/or in temperatures below forty (40) degrees Fahrenheit, inadequate pool water level, or due to user abuse, improper installation, improper chemical balance, normal fading of Fabric color, or failure to comply completely with the Manufacturer's Installation and Owner's Manual guidance.

All Limited Warranty Claims must be pre-authorized by Automatic Pool Covers, Inc. and components are required to be returned to Automatic Pool Covers, Inc. for warranty determination. If Fabric is replaced within the first 36 months, the replacement Fabric will carry the balance of the original warranty.

AUTOMATIC POOL COVERS SYSTEM INFORMATION & HISTORY

COMPLETE THIS FORM AND KEEP FOR FUTURE REFERENCE

SYSTEM TYPE		SERVICE HISTORY AND NOTES
<input type="checkbox"/> THREE·SIXTY·FIVE™	<input type="checkbox"/> AutoGuard	
<input type="checkbox"/> Manual Guard	<input type="checkbox"/> Spa	
TRACK TYPE		
<input type="checkbox"/> Top Track	<input type="checkbox"/> Under Track	
<input type="checkbox"/> Flush Mount		
CONTROLLER TYPE		
<input type="checkbox"/> PowerTouch™ Touchpad	<input type="checkbox"/> Key Switch	
SYSTEM SERIAL NUMBER:		
DATE OF MANUFACTURE:		
INSTALLER:		
DATE OF INSTALL:		
SERVICE COMPANY:		
PHONE NUMBER:		

Place Serial Number
Sticker Here



CONTACT US
AutomaticPoolCovers.com
(800) 878-5789