

SPECIFICATION BOOK 2024

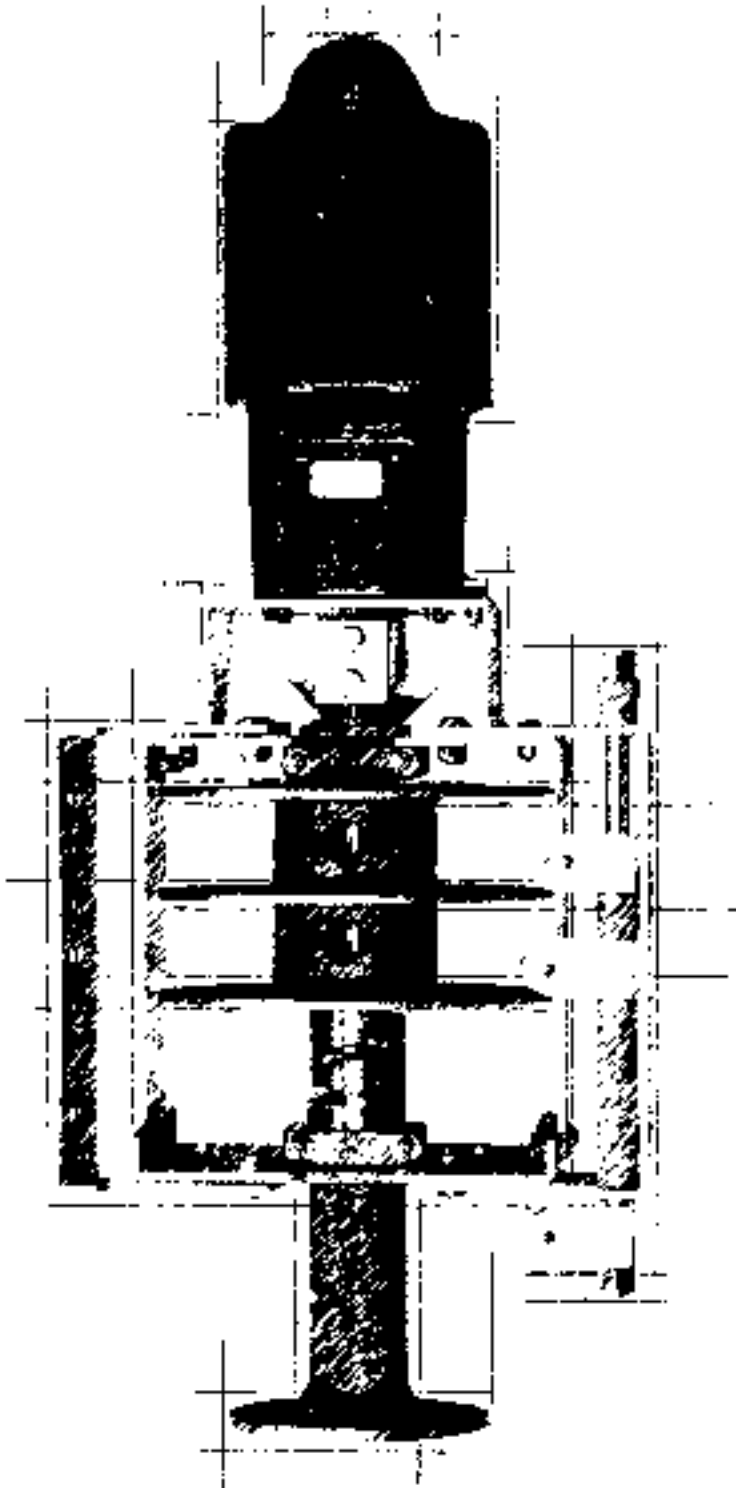
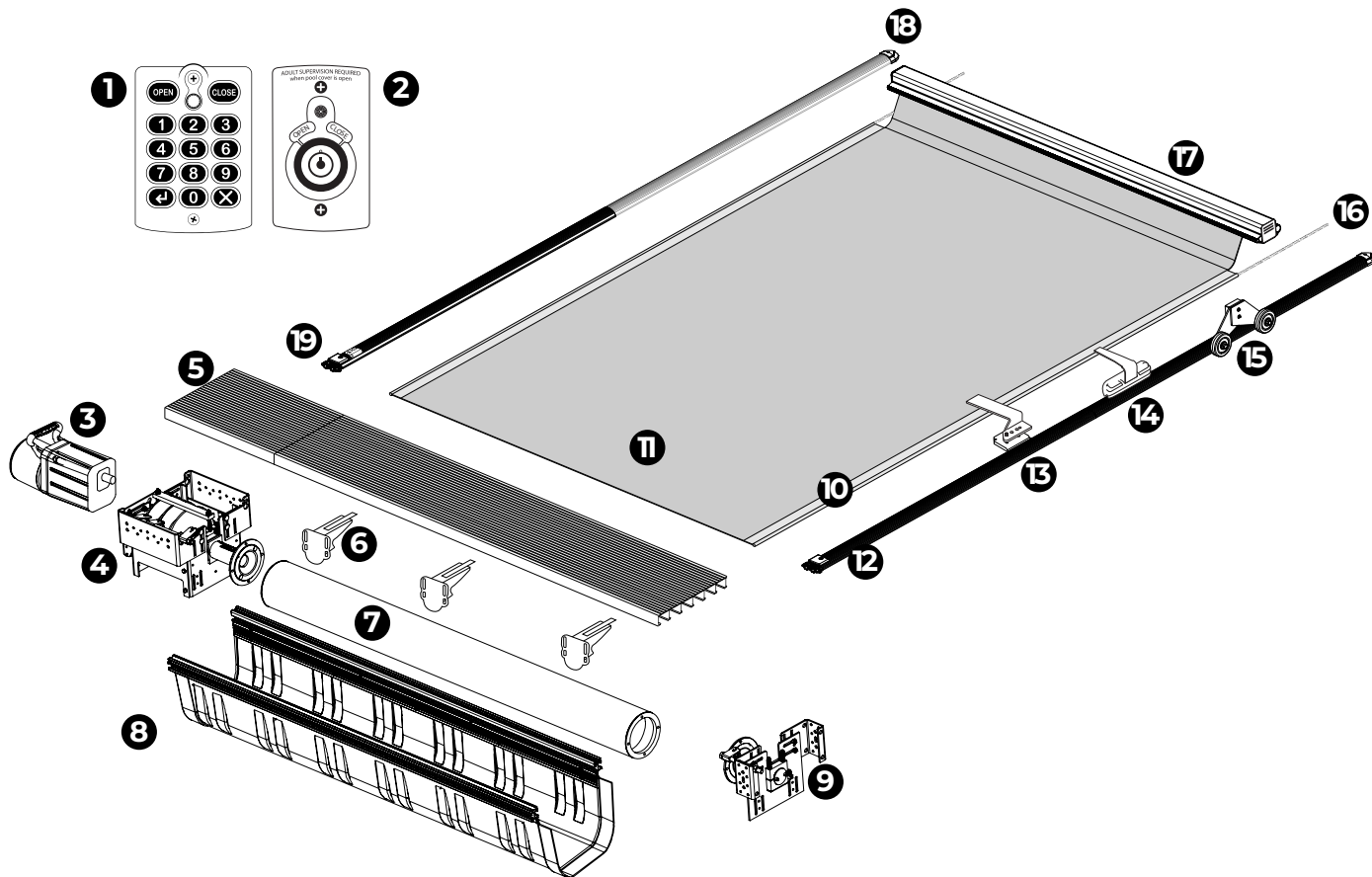

TABLE OF CONTENTS

Glossary.....	2
System Information.....	5
Gliders.....	9
Lid Brackets.....	10
Fabric Corners.....	11
Pre-Installation Checklist.....	13
Retainer Installation.....	15
Polybox Installation.....	23
Flush Lid Risers.....	28
Fiberglass Pool Brackets.....	35
Housings.....	38
Electrical.....	45
Service Diagrams/Instructions.....	54
Troubleshooting Guide.....	80
Unit Installation Instructions.....	81



- 1 TOUCH PAD CONTROLLER** - Page 30
- 2 KEY SWITCH CONTROLLER** - Page 31
- 3 MOTOR** - Page 3
- 4 MECHANISM END**
- 5 LID** - Page 6
- 6 LID BRACKET** - Page 9
- 7 TUBE** - Page 11
- 8 HOUSING** - Wood: Top Track - Page 14, Under Track - Page 16, Concrete - Page 18, Polymer Box - Page 20
- 9 OPPOSITE END**
- 10 WEBBING**
- 11 COVER** - Pages 10-11
- 12 TRACK** - Page 6
- 13 GLIDER** - Page 8
- 14 CARRIAGE** - Page 3
- 15 WHEELS** - Page 3
- 16 ROPE** - Page 11
- 17 LEAD EDGE BAR** - Page 3
- 18 PULLEY CASTING** - Page 4
- 19 ROPE GUIDE** - Page 4
- 20 CORNERS** - Page 4
- 21 RETAINER** - Page 4

CONTROLLERS

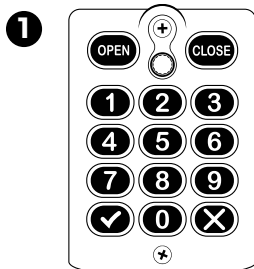

POWERTOUCH
The Touch Pad signals the motor to open or close the cover. Operation is only allowed with a unique personal 4 digit code.

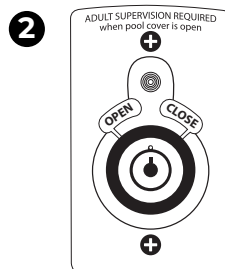

KEY SWITCH
The Key Switch signals the motor to open or close the cover. Operation is only allowed with the proper key.



Glossary

MOTORS 3

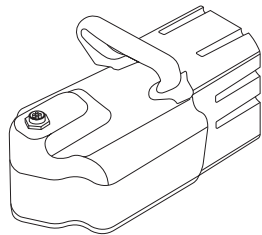

AUTOGUARD

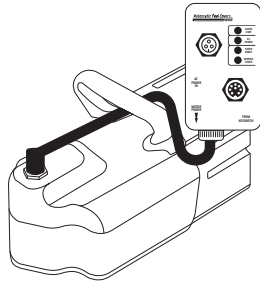

AUTOGUARD with Sensor Motor Adaptor

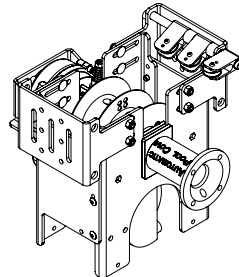

SPA UNIT

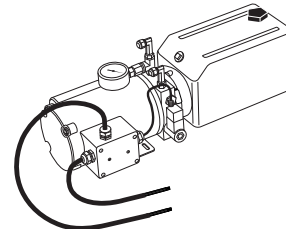

HYDRAULIC

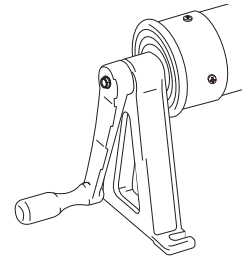

MANUAL GUARD Hand Operated

LID 5

FLUSH LID

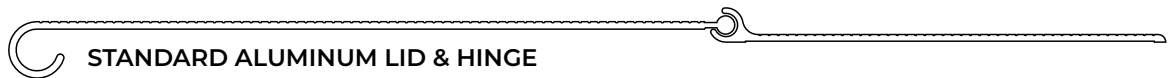
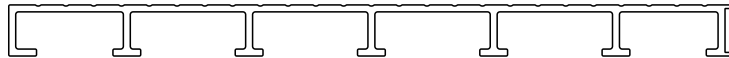

STANDARD ALUMINUM LID & HINGE

LID BRACKET 6

(See details on Page 9)

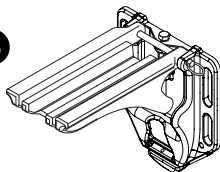

ATLAS

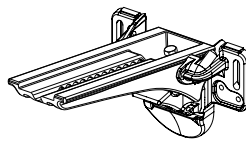

HEAVY DUTY

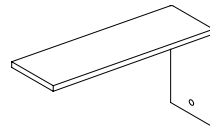

TOP TRACK

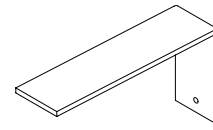

UNDER TRACK

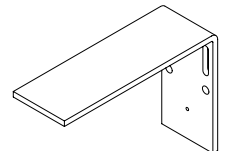

UNDER TRACK HD

TRACKS 12

(See details on Page 6)

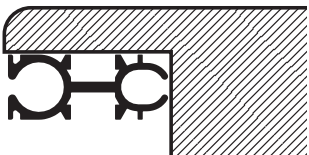

UNDER TRACK (UT)

Mounted under the pool decking (2 & 3 channel)

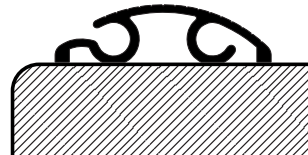

TOP TRACK (TT)

Mounted to the surface of the pool decking



FLUSH TRACK (FT)

Recessed in the surface of the pool decking

LEAD EDGE ASSEMBLY 13 14 15 17

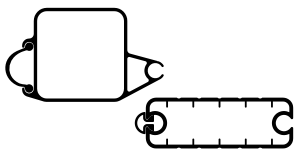

LEAD EDGES

Rigid bar spanning the pool, which the cover is attached. Available in the standard square, or low-profile (available up to 15') design.

GLIDER

Attached to the rope/cover or bracket, and travels inside the track channel, used with Under Track or Top Track

(See details on Page 8)

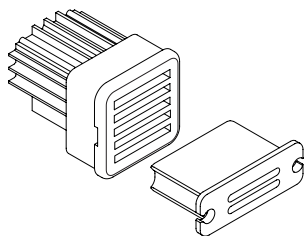
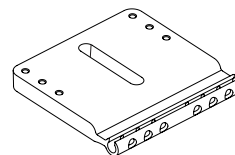

ADJUSTABLE LEAD EDGE DOWELS

Inserted into the end of the Lead Edge. Glider and Carriage brackets are inserted into the slots. The slots allow for Lead Edge height adjustment. Square dowel can be inserted 180° for even more height options.

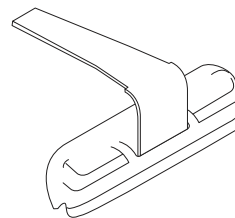

CARRIAGE

Attached to the lead edge, used with top track and flush track

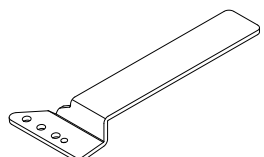

ADJUSTABLE LEAD EDGE BRACKET

Inserts into the Adjustable Lead Edge dowel to attach the Gliders to the Lead Edge.

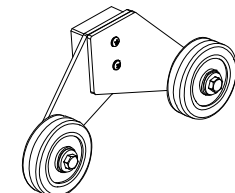

WHEELS

Attached to the lead edge, used with top track

Glossary

PULLEY CASTING 18

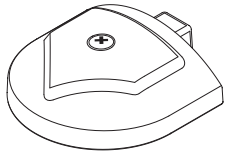

TOP TRACK

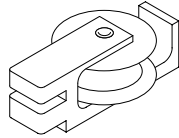

UNDER TRACK
Large 2-Channel

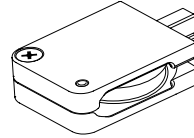

UNDER TRACK
Small 3-Channel

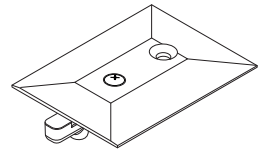

FLUSH TRACK

ROPE GUIDE 19

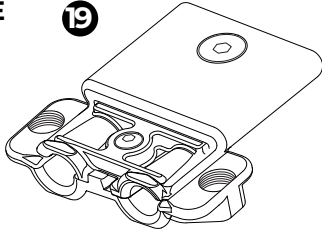

TOP TRACK

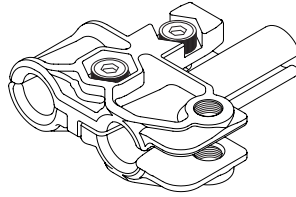

UNDER TRACK
Large 2-Channel

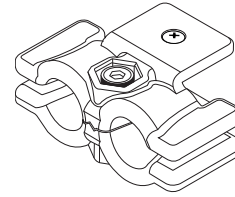

UNDER TRACK
Small 3-Channel

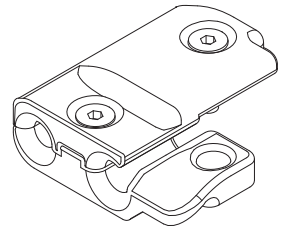

FLUSH TRACK

THREE·SIXTY·FIVE™ - CORNERS 20

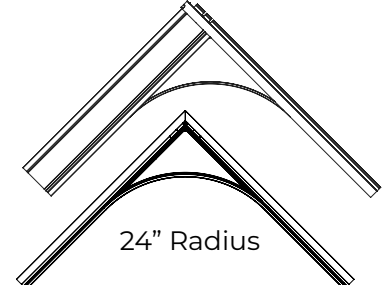
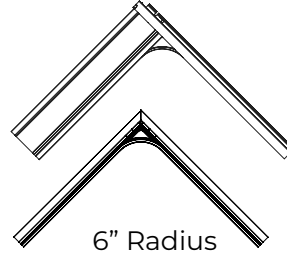
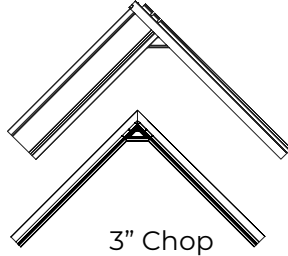
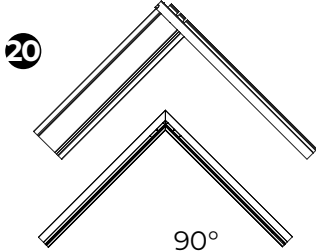

RETAINERS 21

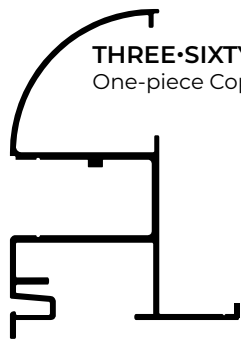

THREE·SIXTY·FIVE™ COPING
One-piece Coping and Form

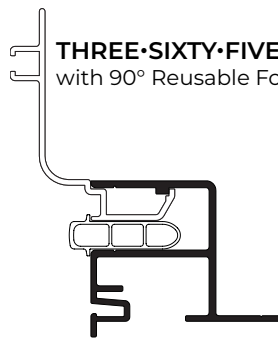

THREE·SIXTY·FIVE™ VINYL LINER RETAINER (VLR)
with 90° Reusable Form & Spacer

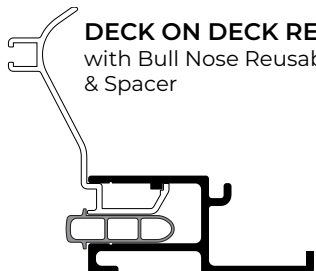

DECK ON DECK RETAINER
with Bull Nose Reusable Form
& Spacer

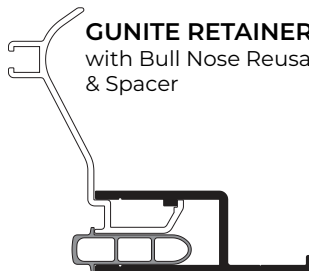

GUNITE RETAINER
with Bull Nose Reusable Form
& Spacer

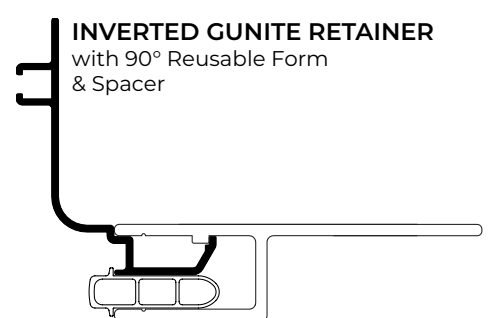

INVERTED GUNITE RETAINER
with 90° Reusable Form
& Spacer

Measuring Track Space & Cut Sizes

THREE-SIXTY-FIVE COPING

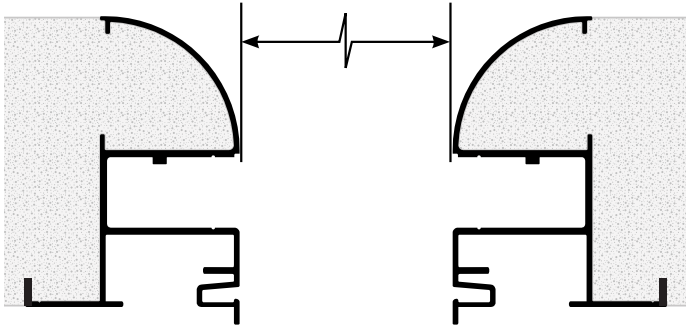

UNDER TRACK

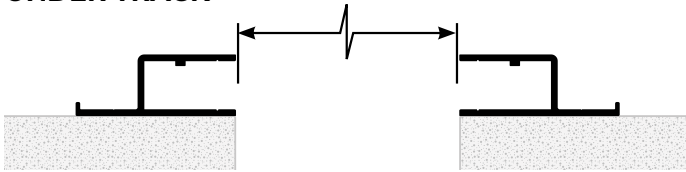

DRILLED UNDER TRACK

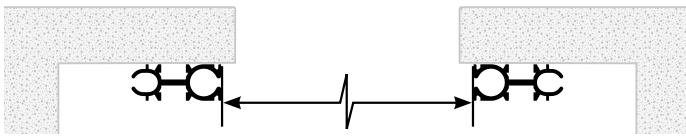

FLUSH TRACK

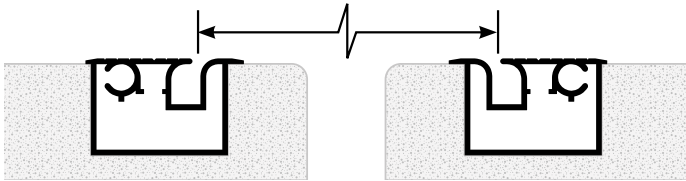

TOP TRACK

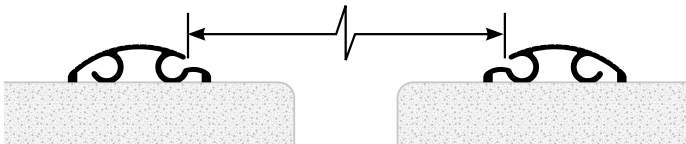

UNDER TRACK LAYOUT

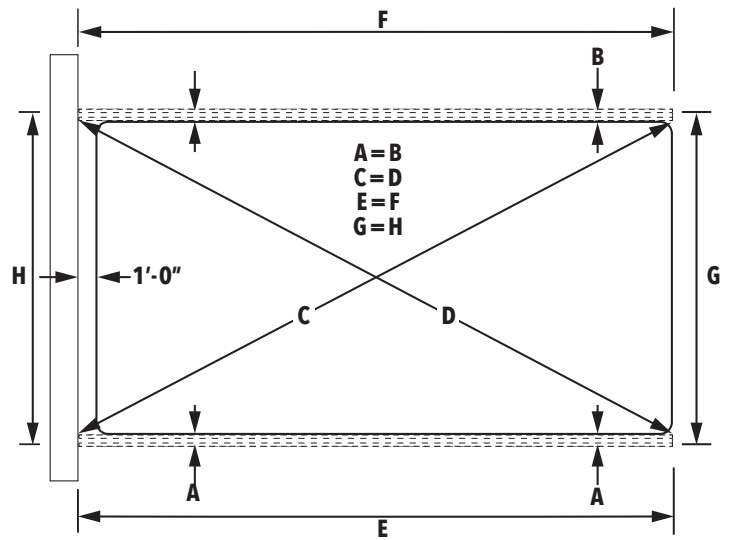

TOP TRACK LAYOUT

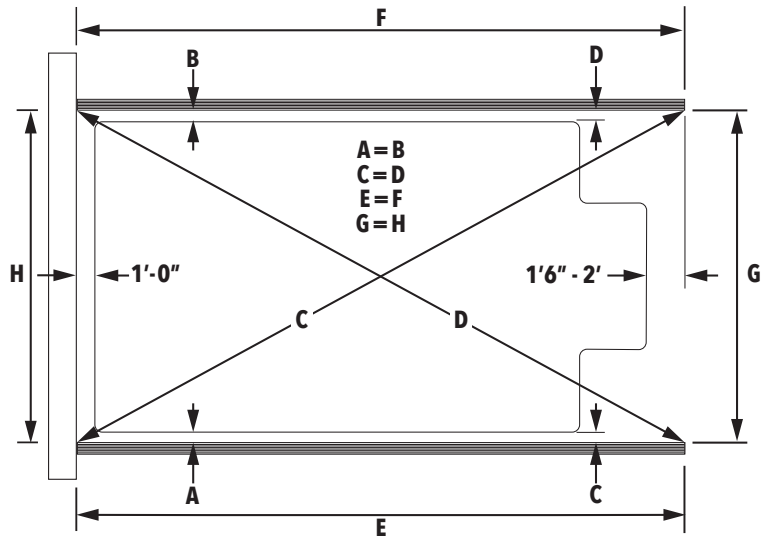

CUT SIZES (Based on Track Width)

RECESSED HOUSING	UNDER TRACK
TOP TRACK / FLUSH TRACK	Lid +7"
Lid +7"	Hinge +67"
Hinge +67"	Drum -5"
Drum -5"	Lead Edge -7"
Lead Edge (Carriage Assy) .. -3"	
Lead Edge (Wheel Assy) +5"	
	365 SYSTEM
	Lid +1' 4"
	Drum -5"
	Lead Edge -7"
DECK MOUNT HOUSING	MANUAL
TOP TRACK / FLUSH TRACK	4" Drum +8"
Drum -5"	Lead Edge (Carriage Assy) -3"
Lead Edge (Carriage Assy) .. -3"	Lead Edge (Wheel Assy) +5"
Lead Edge (Wheel Assy) +5"	

System Components Dimensions

Track

Rope Guide

Pulley

UNDER TRACK Large Channel

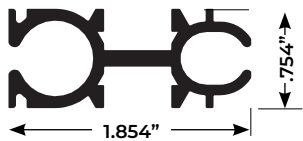

Under Track (Large 2-Channel)
XC 0054, XC 1109 (drilled)

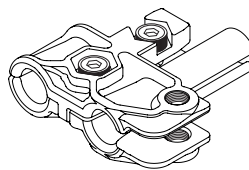

Under Track Guide
Large 2-Channel
MA 0147

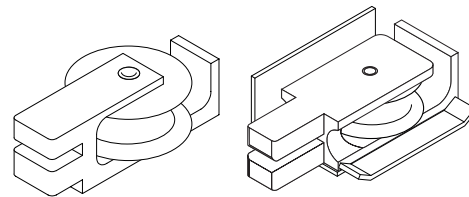

Under Track Pulleys
Large 2-Channel
MA 0121 (use with XC 0054) MA 0142 (use with XC 1109)

UNDER TRACK 3 Channel



Under Track - (Small 3-Channel)
XC 0092, XC 1130 (drilled)

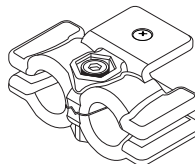

Under Track Guide
Small 3-Channel
RA 0006

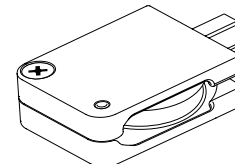

Under Track Pulley
Small 3-Channel
CSA005

FLUSH TRACK

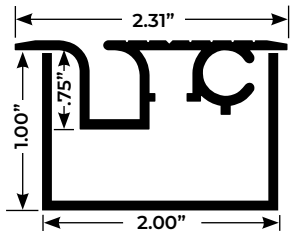

Flush Track - XC 0005
U-Channel - XC 1015

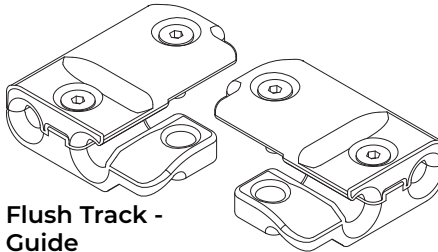

Flush Track - Guide
MA 0182 (Left) MA 0183 (Right)

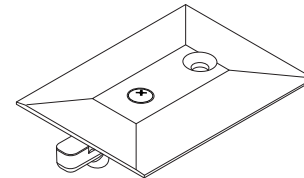

Flush Track - Pulley
MA 0073

TOP TRACK

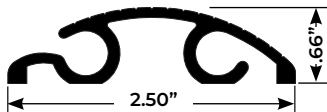

Top Track - Track
XC 0004

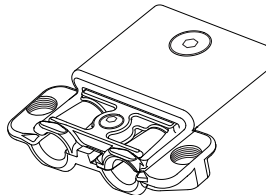

Top Track - Guide
MA 0143

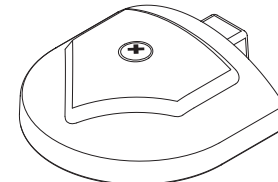

Top Track - Pulley
MA 0014

LIDS

Standard Aluminum Lid - XC 0002 (with 5" Hinge - XC 0014)

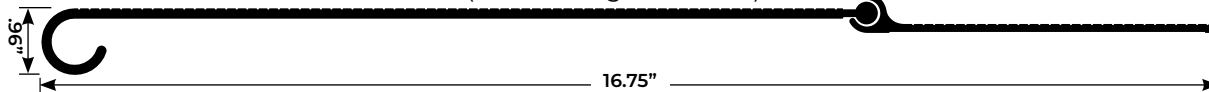

Standard Aluminum Lid - XC 0002 (with 7" Hinge - XC 0078)

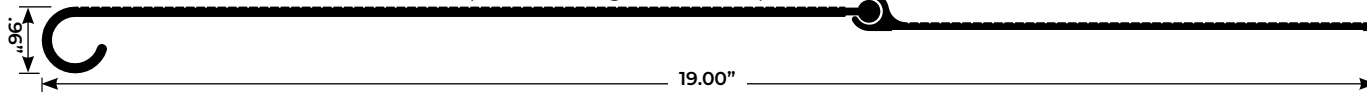

Flush Lid - XC 0004

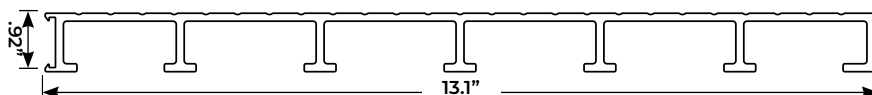

System Components Dimensions

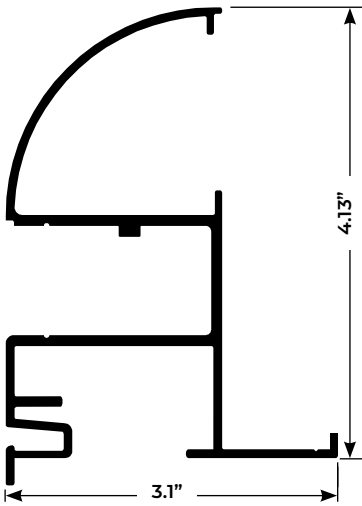

THREE-SIXTY-FIVE™ Coping

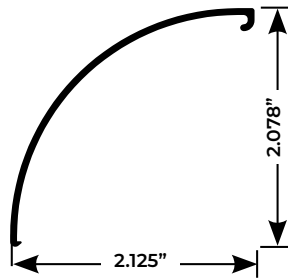

THREE-SIXTY-FIVE™ Coping Clip

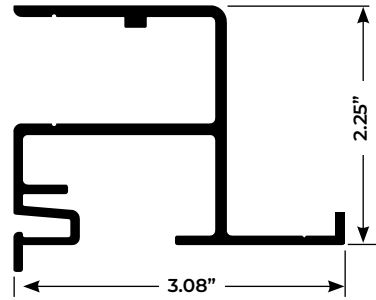

THREE-SIXTY-FIVE™ Vinyl Liner Retainer (VLR)

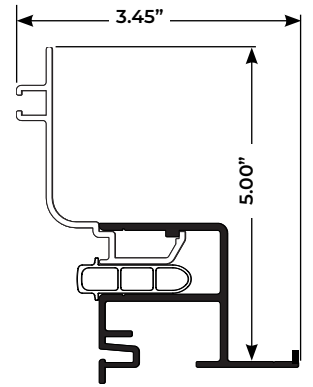

THREE-SIXTY-FIVE™ Retainer with 90° Reusable Form & Spacer

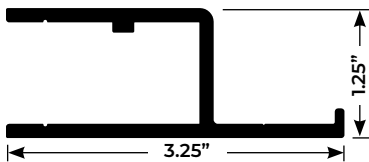

Gunite Retainer
XC 0080 (KA 0186 Kit)

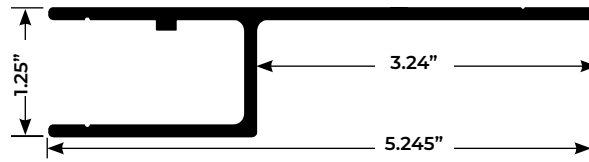

Inverted Gunite Retainer
XC 0085 (KA 0315 Kit)

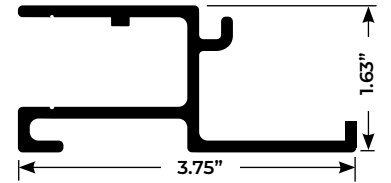

Deck On Deck Retainer
XC 0021 (KA 0133 Kit)

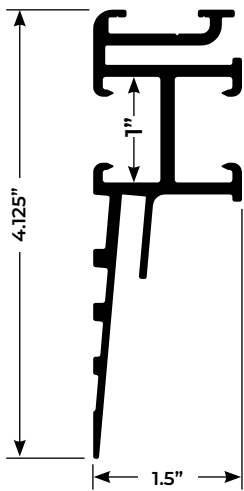

Polymer Box Rail
Factory installed to Polymer Box

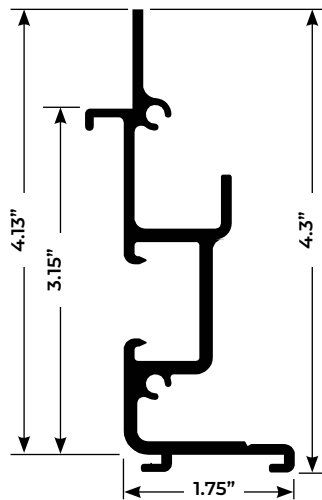

THREE-SIXTY-FIVE Lid Riser

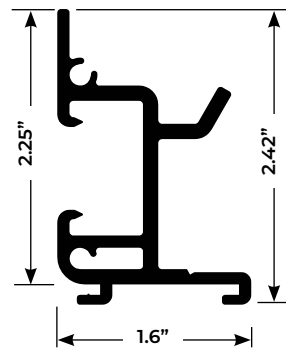

Stone Lid Riser

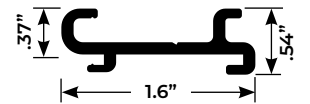

3/8" Extension Riser

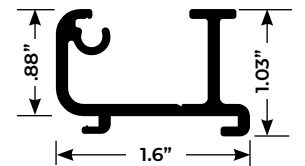

1" Extension Riser

System Components Dimensions

INVERTED GUNITE RETAINER

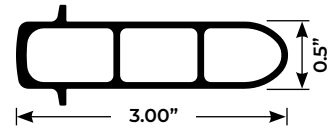
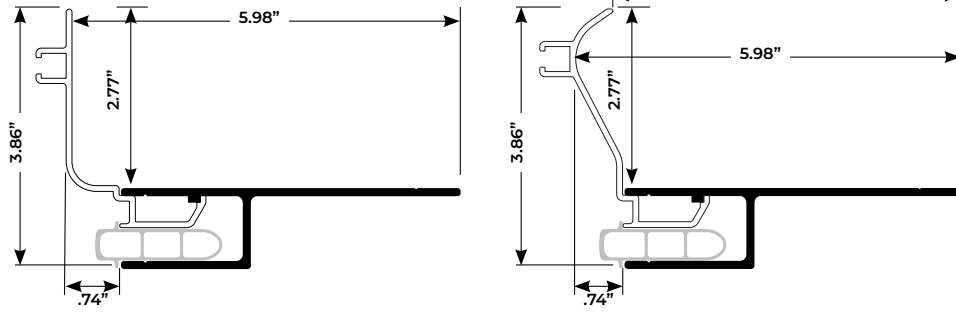

3" Shim
MC 0567

Note: All Reusable Form kits work on systems up to 20' x 50'. Additional pieces may be purchased for larger pool sizes.

GUNITE RETAINER

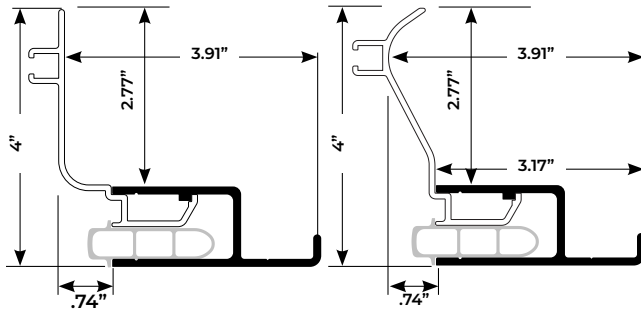

365/VLR RETAINER

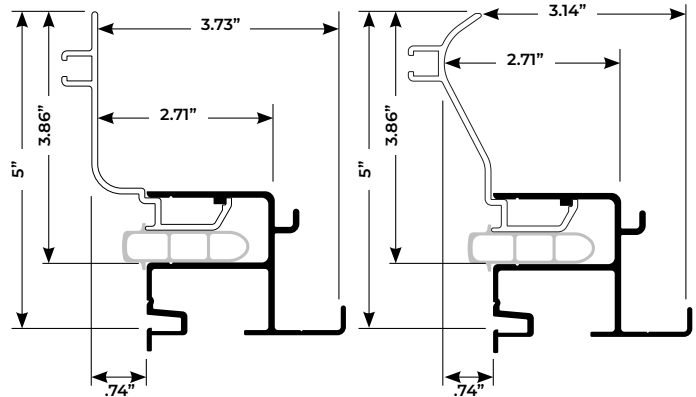

DECK ON DECK RETAINER

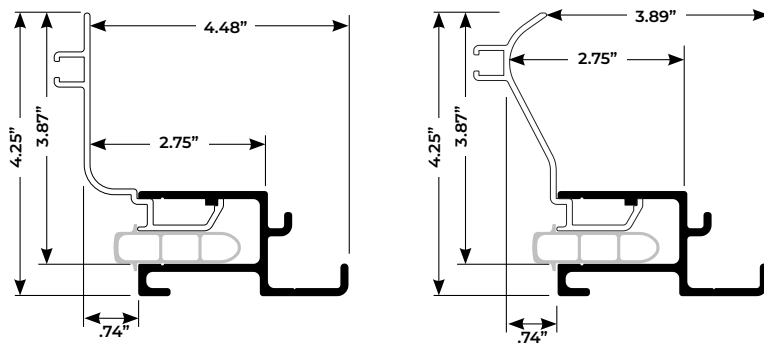

LEAD EDGES

STANDARD AND ANODIZED

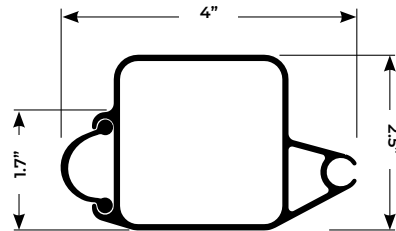

4" TUBE

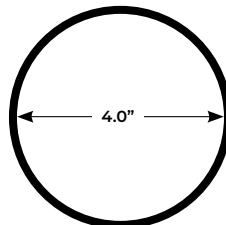

LOW PROFILE

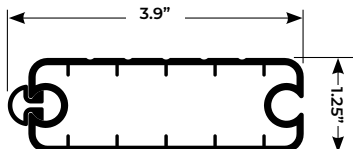

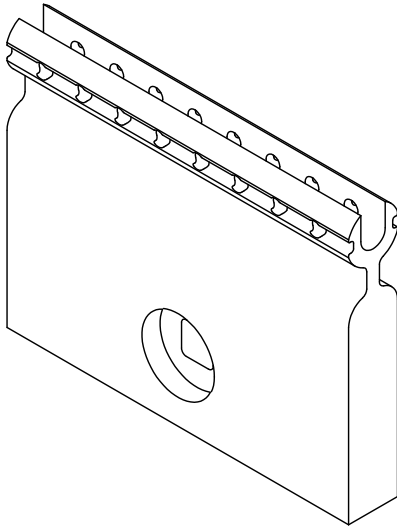

Sew On, Large 2-Channel Under Track
MC0406 - 3.5" W x 2.66" H x .5" D
 (XC0054, XC1109)

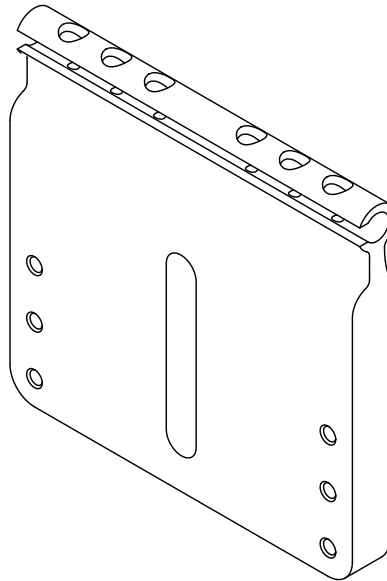

Universal Small 2-Channel Under Track
MC0601 - 3.5" W x 2.7" H x .375" D
 (XC0004, XC0006, XC0007, XC0008)

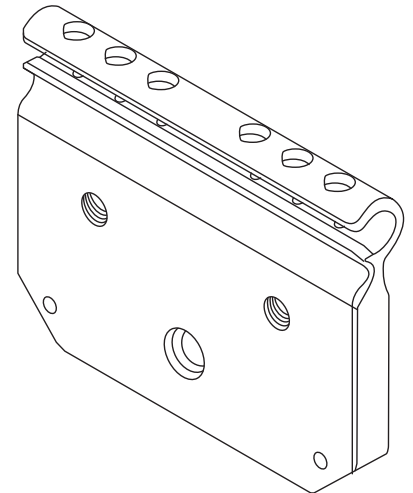

Screw On, Large 2-Channel Under Track
MC0618 - 3.5" W x 3.3" H x .375" D
 (XC0054, XC1109)

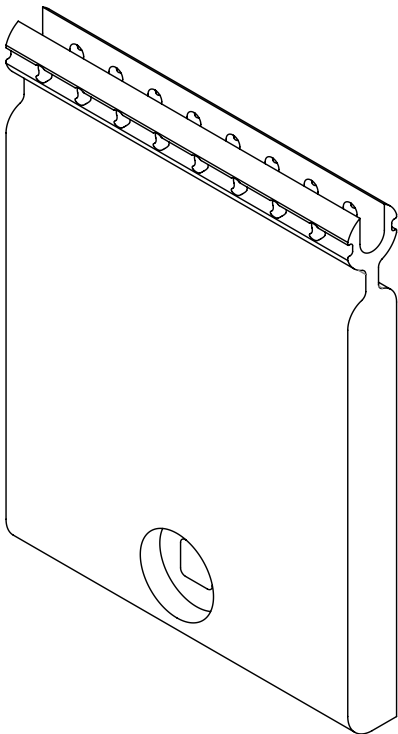

Extra Wide Sew-On Large Channel
MC0641 - 3.5" W x 4.5" H x .5" D
 (XC0054, XC1109)

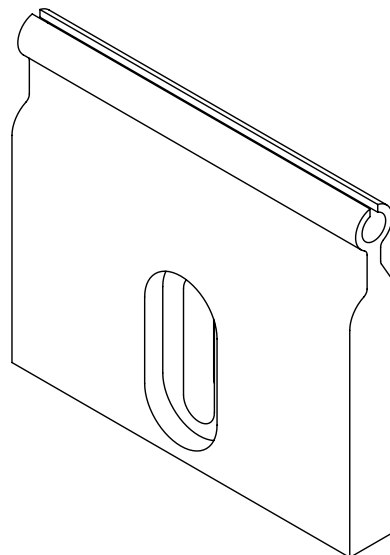

Combined Under Track
MC0688 - 3.5" W x 2.84" H x .5" D
 (XC0004, XC0006, XC0007, XC0008)

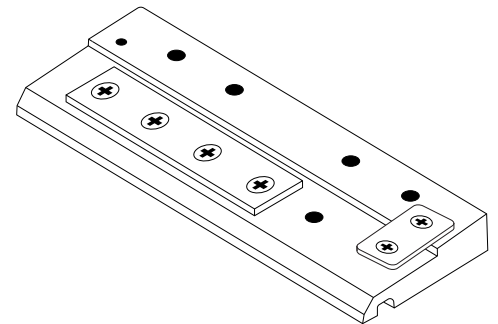

Detachable Black Slider - Large Channel
CSA-018 - 6" W x .5" H x 2.22" D
 (XC0004, XC0006, XC0007, XC0008)

Lid Brackets

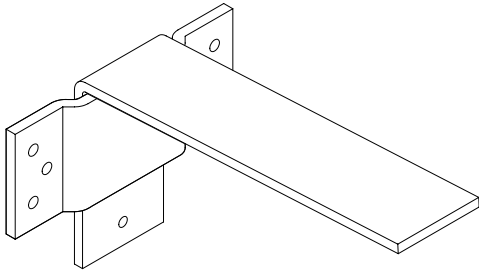

MA 0233
Standard Under Track Lid Mount
Bracket Assy
 Sleeve: **MC 0091** & Bracket: **MC 0125**
 Maximum Weight: **50 lbs.**
 Extension: **10"**
 Using either:
 (4) 1/4" x 1.50" Lag Bolts
 (4) 1/4" x 3.00" Wedge Anchor

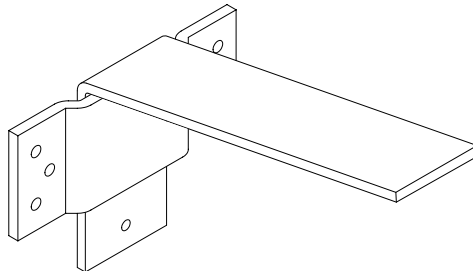

MA 0234
Standard Top Track Lid Mount
Bracket Assy
 Sleeve: **MC 0091** & Bracket: **MC 0059**
 Maximum Weight: **50 lbs.**
 Extension: **9.84"**
 Using either:
 (4) 1/4" x 1.50" Lag Bolts
 (4) 1/4" x 3.00" Wedge Anchor

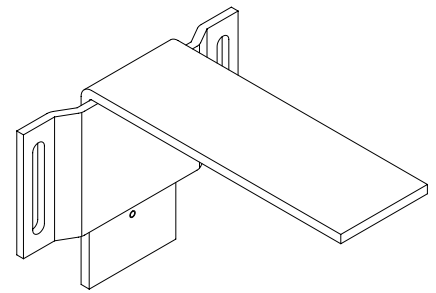

MA 0235
Heavy Duty Under Track Lid
Mount Bracket Assy
 Sleeve: **MC 0237** & Bracket: **MC 0061**
 Maximum Weight: **125 lbs.**
 Extension: **12"**
 Using only:
 (2) 3/8" x 5.00" Wedge Anchor

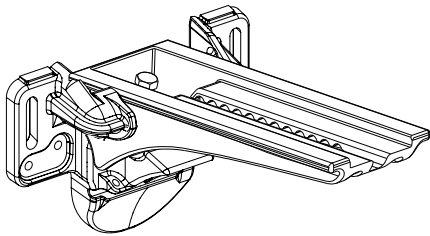

KA 0335
HD2 - Heavy Duty Lid Bracket Assy No
Extension
 (1) MC 0191 - HD II Mount Assembly
 (1) MC 0192 - HD II Arm Assembly
 (1) MC 0257 - HD Aluminum Bracket Arm
 Maximum Weight: **300 lbs.**
 Extension: **11"**
 Using only:
 (2) 3/8" x 5.00" Wedge Anchor

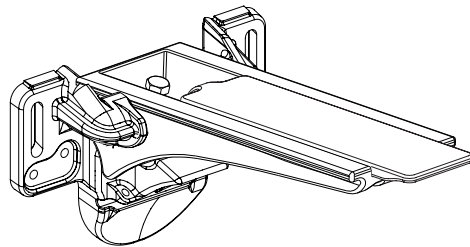

KA 0336
HD3 - Heavy Duty Lid Bracket Assy
w/Extension
 (1) MC 0191 - HD II Mount Assembly
 (1) MC 0192 - HD II Arm Assembly
 Maximum Weight: **175 lbs.**
 Extension: **12" - 16"**
 Using only:
 (2) 3/8" x 5.00" Wedge Anchor

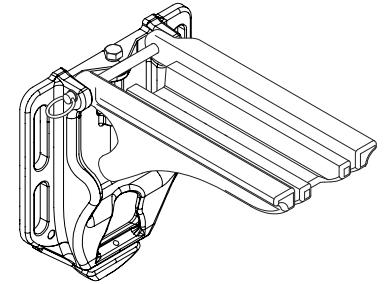

KA 0309
Atlas - Extreme Duty Bracket No
Extension
 (1) MA 0165 - Extreme HD II Bracket Mount
 without Extension
 Maximum Weight: **640 lbs.**
 Extension: **No Extension**
 Using only:
 (2) 1/2" x 5.50" Wedge Anchor

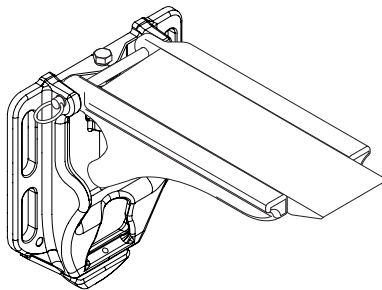

KA 0310
Atlas - Extreme Duty II Bracket -
Short Extension
 (1) MA 0165 - Extreme Duty II Bracket Mount
 w/o Ext.
 (1) MC 0664 - Extension Arm
 Maximum Weight: **435 lbs.**
 Extension: **12" - 16"**
 Using only:
 (2) 1/2" x 5.50" Wedge Anchor

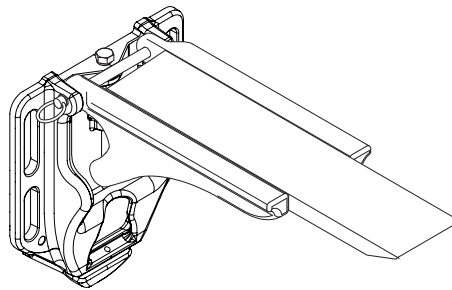

KA 0311
Atlas - Extreme Duty II Bracket -
Medium Ext.
 (1) MA 0165 - Extreme Duty II Bracket Mount
 w/o Ext.
 (1) MC 0663 - Extension Arm
 Maximum Weight: **370 lbs.**
 Extension: **17" - 20"**
 Using only:
 (2) 1/2" x 5.50" Wedge Anchor

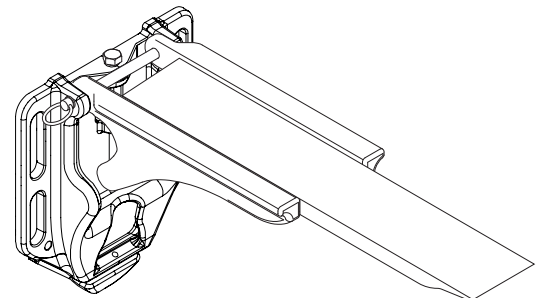

KA 0312
Atlas - Extreme Duty II Bracket -
Long Ext.
 (1) MA 0165 - Extreme Duty II Bracket Mount w/o
 Ext.
 (1) MC 0663 - Extension Arm
 Maximum Weight: **325 lbs.**
 Extension: **21" - 24"**
 Using only:
 (2) 1/2" x 5.50" Wedge Anchor

Fabric Corners, Tubes, Rope

TOP TRACK

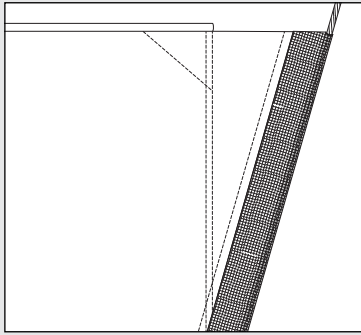

Standard Gore (Wheels)

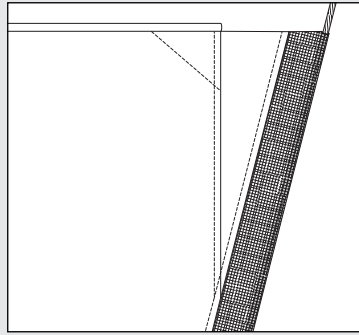

Standard Gore - 3" Small (Wheels)

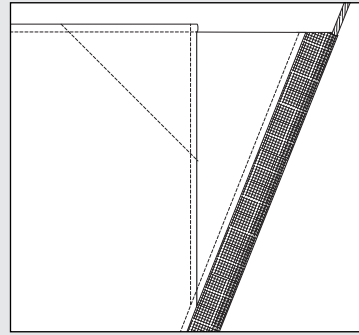

Xtra Large Gore (Wheels)

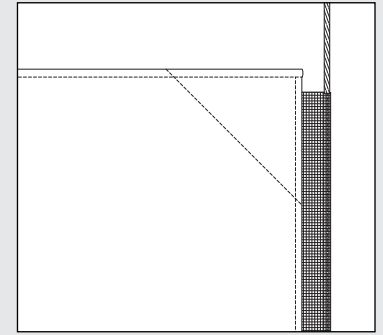

Top Track Glider

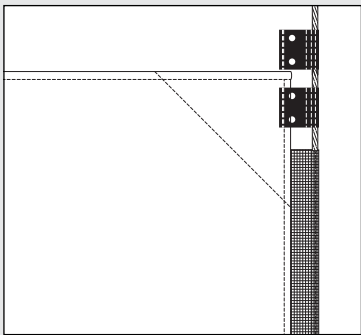

Top Track Torque Limit (Carriages)

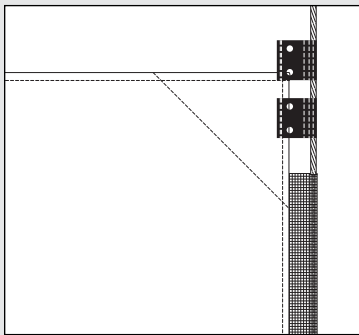

XL Top Track Torque Limit (Carriages)

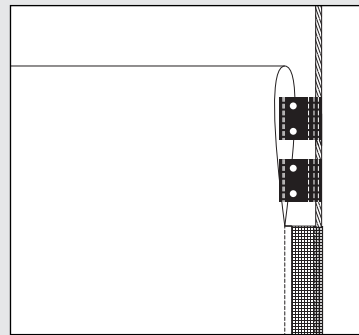

Torque Limit w/6.75" Loop (up to 3" LE) - (Carriages)

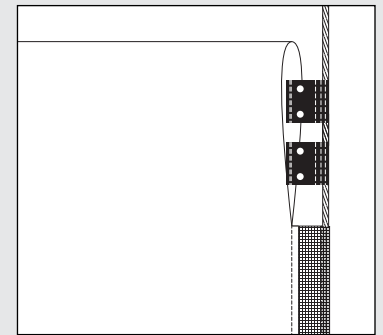

Torque Limit w/7.75" Loop (up to 4" LE) - (Carriages)

UNDER TRACK

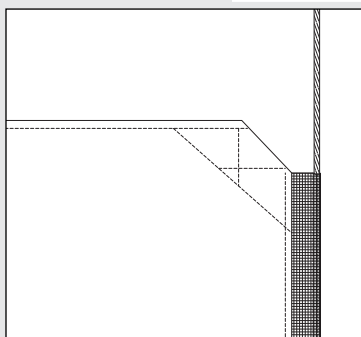

Standard Ale (Small Channel)

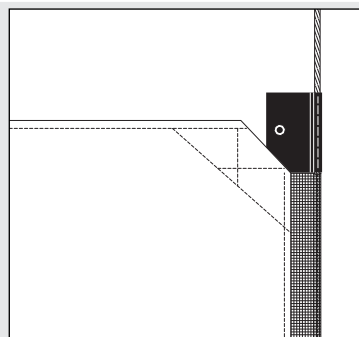

Ale with Gliders (Large Channel)

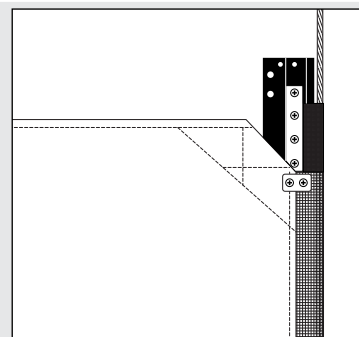

Ale with Black Slider (3 Channel)

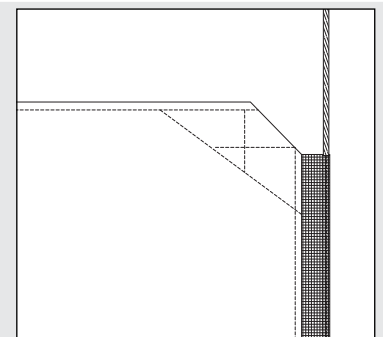

ALE (for Aquamatic)

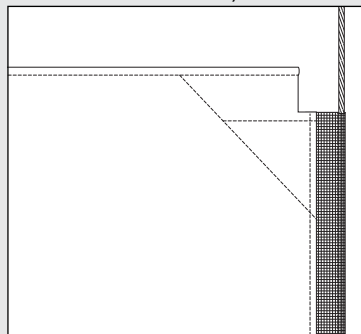

No Gore - 2" x 2" California CP

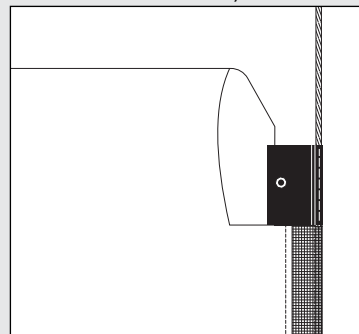

Glider Only w/6.75" Loop (up to 3" LE)

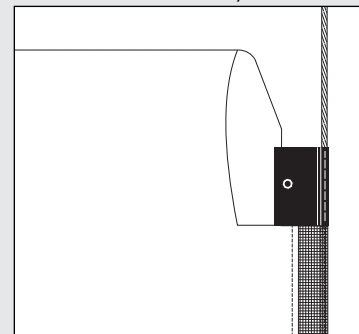

No Gore w/7.75" Loop (up to 4" LE)

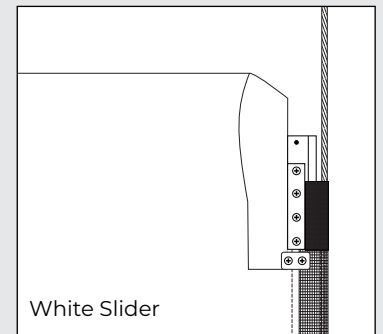

White Slider

No Gore w/6.75" Loop (up to 3" LE)

UNDER TRACK

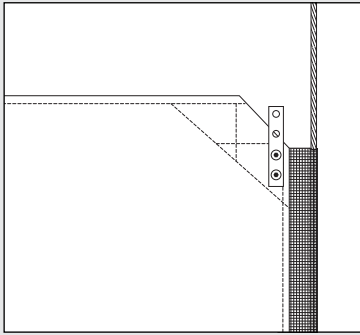

WET ALE (Includes Straps)

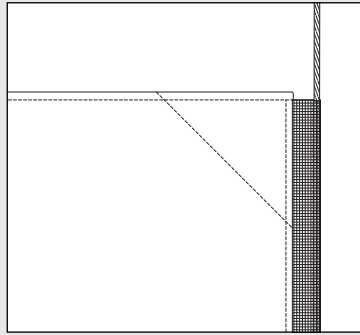

No Gore

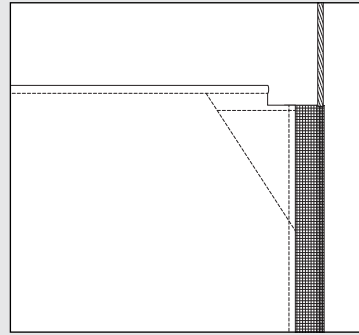

No Gore - 1/2" x 2"

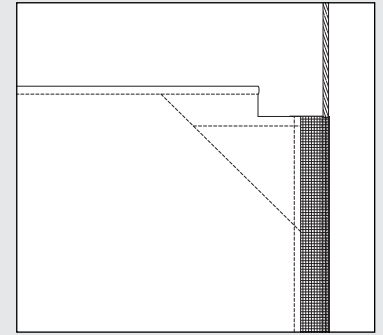

No Gore - 1" x 3"

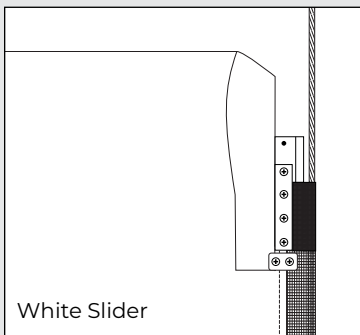

White Slider

No Gore w/7.75" Loop
(up to 4" LE)

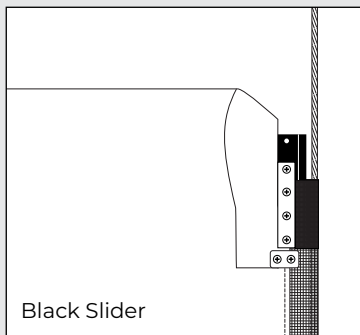

Black Slider

No Gore w/6.75" Loop
(up to 3" LE)

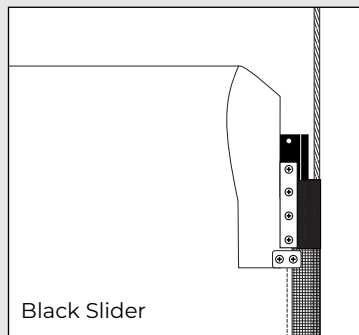

Black Slider

Glider Only w/7.75" Loop
(up to 4" LE)

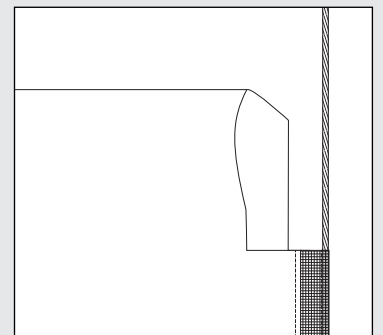

No Gore w/6.75" Loop
(up to 3" LE)

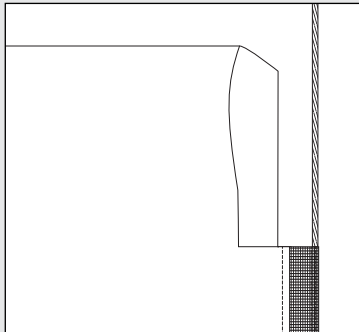

No Gore w/7.75" Loop (up to 4" LE)

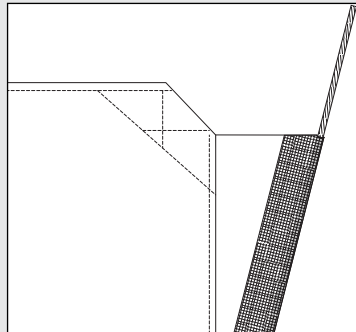

Vanishing Edge (Large Channel) Left or Right

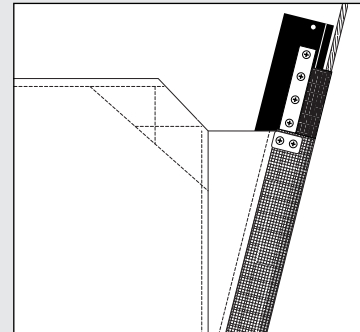

Vanishing Edge (3 Channel) Left or Right

TUBES

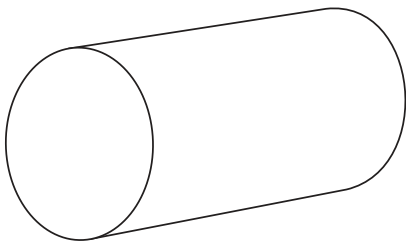

Aluminum Tube

Diameter: 4" - Lengths: 20', 30', 35'
Diameter: 6" - Lengths: 15', 17', 19', 24', 30', 35'
Diameter: 8" - Length: 40'

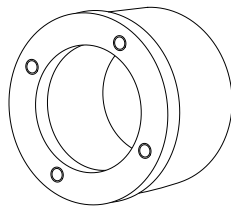

Aluminum Tube Ring

Joins the Tube to the Mechanism

ROPE

INVIS-A-ROPE

Diameter: 0.250"

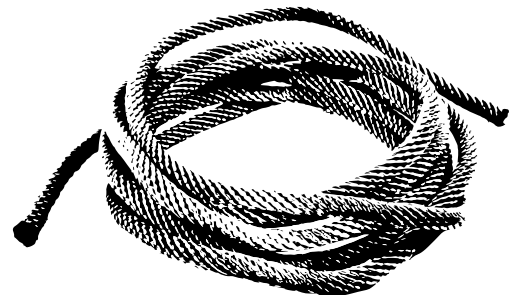

SITE PREPARATION

To ensure the automatic pool cover systems can be properly installed, make sure the pool site is properly prepared for the installation. Please check off items below to ensure site properly prepared:

- Water level is at normal operating level (middle of skimmer).
- Remove any potential obstructions (i.e. grab rails, ladders, slides, sports poles, fountains) before running the automatic cover.
- Deck has been completed and secured (no pavers) with plenty of room for track and lid assembly.
- Recessed housing is free of concrete, nails, or any other type of obstruction.
- Recessed housing is correct height, width, and length.
- Recessed housing is square to pool sides.
- Electrical and remote controller wires are in place with GFCI protection.
- Retainer is free of debris and/or concrete.
- Measurement of pool track space, track length, and diagonal are consistent with order.
- Pool bonding wire in place (if applicable).
- Proper and adequate drainage in recessed housing to remove ground water quickly

ORDER ACCURACY

When you receive the automatic pool cover, inspect all delivered parts to ensure accuracy and that all items are included for the installation.

- All parts correct and included.
- All contents are free from any damage.
- Order received matches what was originally ordered and is within the range of acceptance.
- Fabric color correct.
- All extrusions and cover are correct for the final pool measurements. Note: Cover will be approximately 6" - 8" wider than the track space.

If you're not able to check off any item above, please contact your automatic pool cover supplier immediately.

Recommended Installation Tools

The tools listed below are necessary or helpful in the installation of many Automatic Pool Cover products and we recommend you have available.

- ▶ Cordless drill
- ▶ Electric drill (preferably a hammer drill)
- ▶ Right angle drill (optional)
- ▶ Circular saw or Jigsaw (cordless)
- ▶ Extension cord(s)
- ▶ Flat head screwdrivers
- ▶ Hacksaw with 18 tooth blade
- ▶ Allen wrench set
- ▶ Wire strippers with cutters
- ▶ Hammer
- ▶ Flat shovel
- ▶ Box knife
- ▶ Scissors
- ▶ Mallet
- ▶ 25 ft. tape measure
- ▶ 100 ft. tape measure
- ▶ Sockets:
7/16", 1/2", 9/16"
- ▶ Wrenches:
3/8", 7/16", 1/2", 9/16"
- ▶ Drill bits:
5/32", 11/64", 1/4", 5/16"
1/4" x 4" masonry bit
1/4" x 6" masonry bit
1/2" x 4" masonry bit
#2 Phillips bit
#3 Phillips bit
- ▶ 5/16" Nut driver
- ▶ 7/16" Socket driver
- ▶ Countersink
- ▶ 12" Torpedo level
- ▶ 1/2" Round bastard file
- ▶ 100 ft. string
- ▶ Lighter or butane torch
- ▶ Vinyl Electrician's Tape
- ▶ Broom or cordless vacuum

Gunite Retainer Installation

Gunite Retainer, Inverted Gunite Retainer and Deck on Deck Retainer

REQUIRED MATERIALS

1. Cordless drill
2. Hammer drill
3. Hammer
4. 50' Tape Measure
5. 5/16" drill bit
6. 1/4" Masonry bit
7. #3 Phillips bit
8. Painter's Tape
9. Saw (aluminum blade)

PARTS IDENTIFICATION

GUNITE RETAINER



XC0080 - 22' Length or
XC1162 - 11' Length

DECK ON DECK RETAINER



XC0021 - 22' Length

INVERTED GUNITE RETAINER



XC0085 - 22' Length or
XC1161 - 11' Length

 HC0106 Plastic Anchor

 HC0035 Track Screw

 XC0023 Filler Retainer

PREPARATION

1. Check pool measurements and take diagonal. Diagonal must be <math><2''</math>.
2. Gunite wall should be leveled to prepare for retainer. If the water's edge of gunite wall will be notched to lower retainer elevation, level the notch (do NOT fill in the notch).
3. Decide on gunite retainer overhang from pool walls. There is no need for overhang if tile is not installed before the retainer.

INSTRUCTION

1. Starting at the end of the pool opposite the cover box, place (1) piece of Retainer on the water side of the gunite wall. Make sure the end of the retainer extends 2" past the end wall. **Note:** Inverted Gunite Retainer should be even with the end wall.

Gunite Retainer, Deck on Deck Retainer: The amount the retainer overhangs the water edge of pool wall is determined by pool requirements and design, especially tile selection.

Inverted Gunite Retainer: The retainer will extend down the face of the tile or tile area. If tile is not installed, overhang retainer to allow for tile to be installed.

2. Use cordless drill with a 5/16" bit to drill a hole through the retainer. Then use hammer drill with a 1/4" masonry bit, drill through the hole in the retainer and into the wall approximately 2-1/2".
3. Locate the 1-3/4" Track Screws (HC0035) and Plastic Anchors (HC0106), move track and place an Anchor into each hole.
4. Move retainer back into position and twist the screw into each anchor through each hole in the retainer and lightly tap the screw with a hammer to set the anchor deeper into the hole, approximately 1/4" past top surface.
5. Tighten screws with #3 Phillips bit.
6. Continue drilling down the piece of retainer, until all holes are drilled and secured.

7. Lay the next piece of retainer on the wall, butting it up next to the retainer just installed.

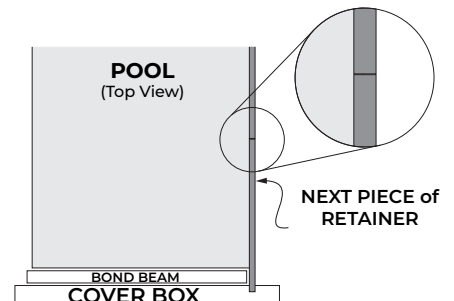
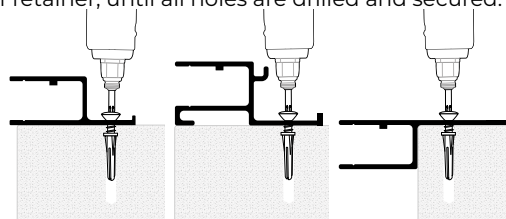
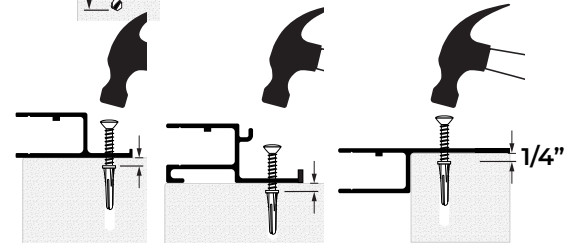
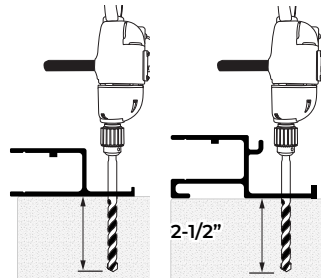
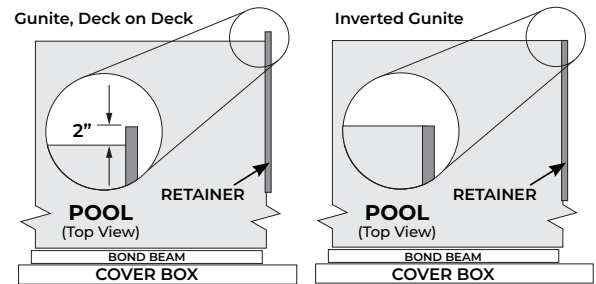

Gunite Retainer Installation

NOTE: To ensure the alignment of the retainer while the deck is being poured, Splice Kit KA0492 is available (sold separately) to insert at joints between the pieces of retainer.

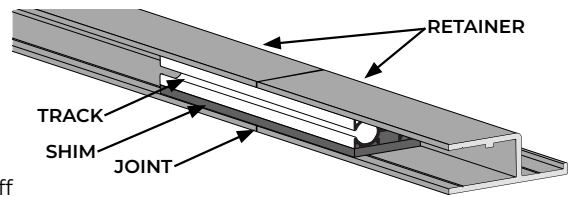

- Retainer should extend into cover box 1". Use a straight edge and cut off excess retainer.

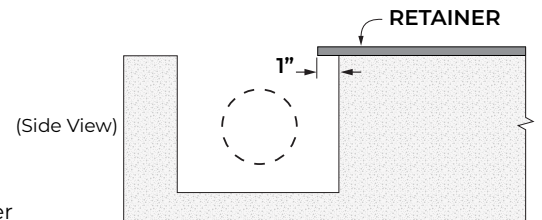

- Using a saw with an aluminum blade, cut a notch 1-1/2" on the top of the retainer so you will be able to secure the track during installation.

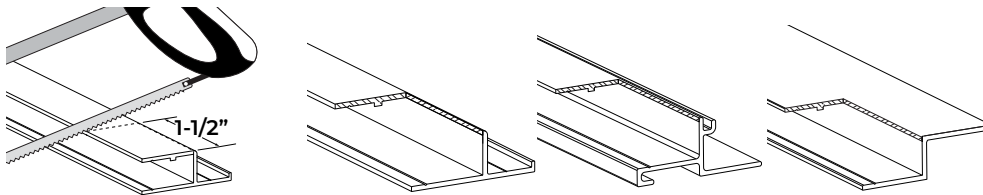

- Cut a notch on the back side the same distance as the cut made on the top.

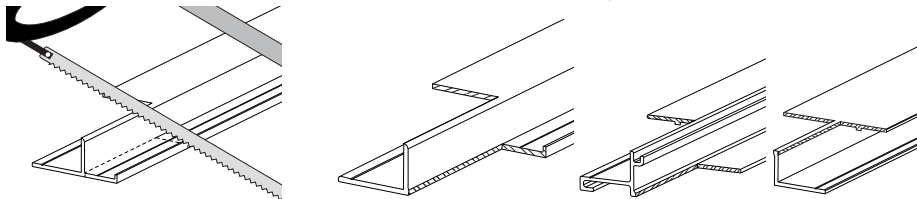

- Drill and secure piece of retainer as in Step 3 and Step 4.
- Repeat steps 1-11 for the opposite side.
- Retainer will be installed next at the end of the pool opposite the cover box between the retainer pieces already installed. Measure the width between retainer and install retainer ensuring the corners are square where the retainers meet the retainer installed on each side of pool.

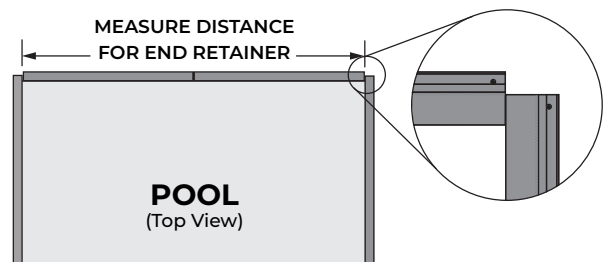

- To prevent concrete flowing in, create a temporary seal prior to deck pour or stone coping installation by taping off each opening at the end of the retainers using tape.
- Insert a piece of Filler Strip (XC0023) into the end retainer starting on one side. Measure the remaining space, then cut an appropriate piece of Filler Strip, and insert into the retainer.









TOOLS NEEDED

- | | | |
|-------------------------|--------------------|---------------------|
| 1. Cordless drill | 2. Hammer drill | 3. Hammer |
| 4. Saw (aluminum blade) | 5. 5/16" drill bit | 6. 1/4" Masonry bit |
| 7. #3 Phillips bit | 8. Painter's Tape | 9. 50' Tape Measure |

PARTS IDENTIFICATION

	XC0080 - 22' Length or XC1162 - 11' Length Gunite Retainer		HC0035 Track Screw
	XC0023 Filler Retainer		HC0106 Plastic Anchor

PREPARATION

1. Check pool measurements and take diagonal. Diagonal must be <math>< 2''</math>.
2. Gunite wall should be leveled to prepare for retainer. If the water's edge of gunite wall will be notched to lower retainer elevation, level the notch (do NOT fill in the notch).
3. Decide on gunite retainer overhang from pool walls. There is no need for overhang if tile is not installed before the retainer.

INSTALLATION

- Step 1** Starting at the end of the pool opposite the cover box, place (1) piece of drilled of Gunite Retainer (XC0023 - 22' or XC1162 - 11') on the water side of the gunite wall. Make sure the end of the retainer extends 2" past the end wall. (The amount the retainer overhangs the water edge of pool wall is determined by pool requirements and design, especially tile selection.)
- Step 2** Use cordless drill with a 5/16" bit to drill a hole through the retainer. Then use hammer drill with a 1/4" masonry bit, drill through the hole in the retainer and into the wall approximately 2-1/2".
- Step 3** Locate the 1-3/4" Track Screws (HC0035) and Plastic Anchors (HC0106), move track and place an Anchor into each hole.
- Step 4** Move retainer back into position and twist the screw into each anchor through each hole in the retainer and lightly tap the screw with a hammer to set the anchor deeper into the hole, approximately 1/4" past top surface.
- Step 5** Tighten screws with #3 Phillips bit.
- Step 6** Continue drilling down the piece of retainer, until all holes are drilled and secured.
- Step 7** Lay the next piece of retainer on the wall, butting it up next to the retainer just installed.

GUNITE/CONCRETE RETAINER

Installation Instructions

Step 1

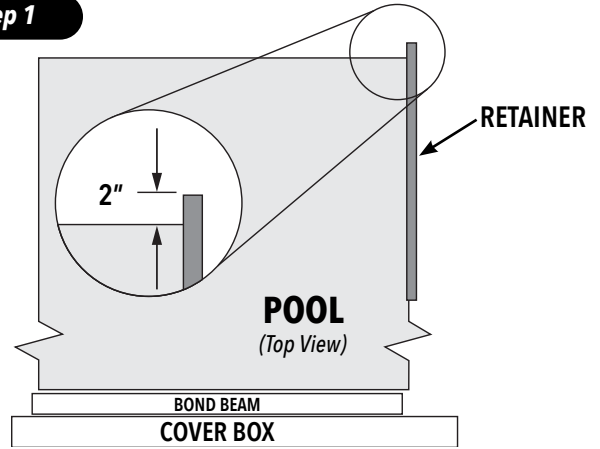

Step 2

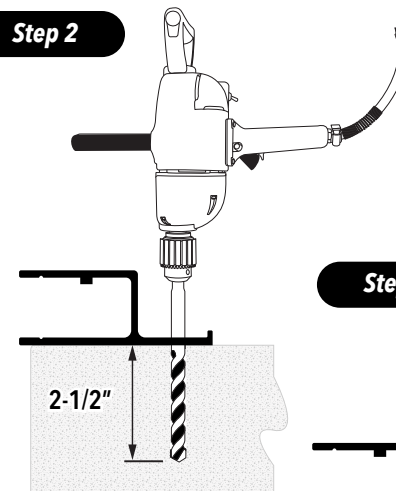

Step 4

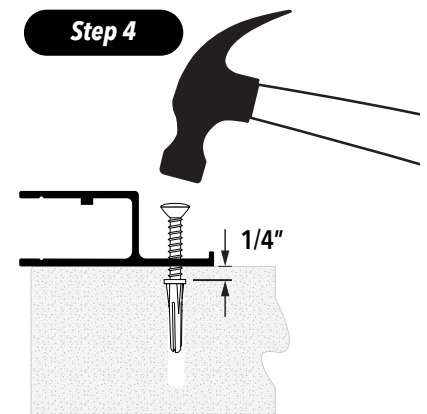

Step 5

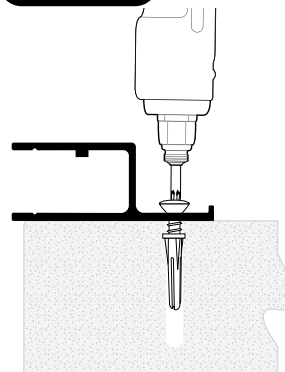

Step 7

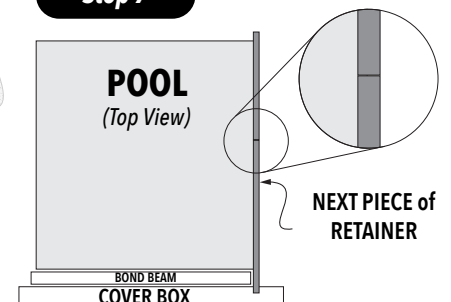

INSTALLATION (CONTINUED)

NOTE: To ensure the alignment of the retainer while the deck is being poured, Splice Kit KA0492 is available (sold separately) to insert at joints between the pieces of retainer.

Step 8 Retainer should extend into cover box 1". Use a straight edge and cut off excess retainer.

Step 9 Using a saw with an aluminum blade, cut a notch 1-1/2" on the top of the retainer so you will be able to secure the track during installation.

Step 10 Cut a notch on the back side the same distance as the cut made on the top.

Step 11 Drill and secure piece of retainer as in Step 3 and Step 4.

Step 12 Repeat steps 1-12 for the opposite side.

Step 13 Retainer will be installed next at the end of the pool opposite the cover box between the retainer pieces already installed. Measure the width between retainer and install retainer ensuring the corners are square where the retainers meet the retainer installed on each side of pool.

Step 14 To prevent concrete flowing in, create a temporary seal prior to deck pour or stone coping installation by taping off each opening at the end of the retainers using painter's masking tape. **Do not use any other form of tape.** (Does not apply if using reusable form.)

Step 15 Insert a piece of Filler Strip (XC0023) into the end retainer starting on one side. Measure the remaining space, then cut an appropriate piece of Filler Strip, and insert into the retainer.

Gunite Retainer installation is complete.

NOTE

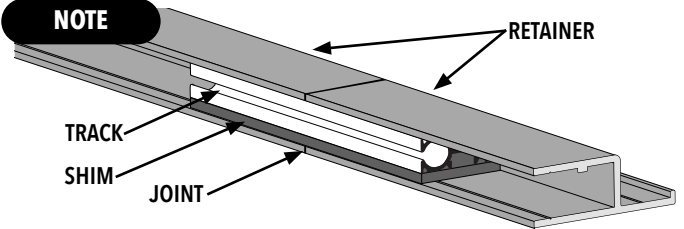

Step 9

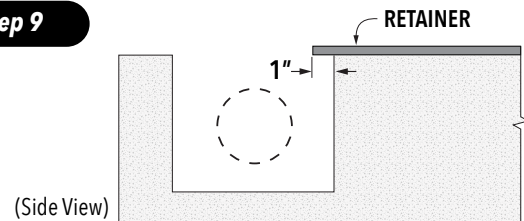

Step 9

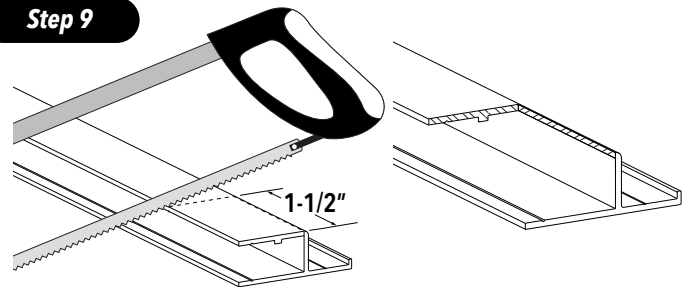

Step 10

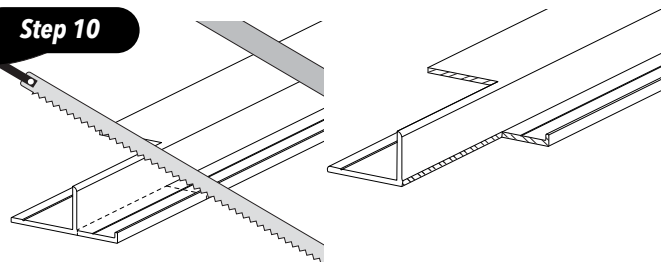

Step 13

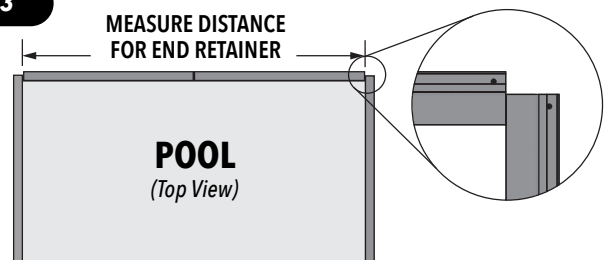

Step 15



TECHNICAL SUPPORT

If you have any questions about these installation procedures, please contact Technical Support at (800) 878-5789.

Automatic Pool Covers, Inc.

(800) 878-5789 • automaticpoolcovers.com

DECK ON DECK RETAINER Installation Instructions

TOOLS NEEDED

- | | | |
|-------------------------|--------------------|---------------------|
| 1. Cordless drill | 2. Hammer drill | 3. Hammer |
| 4. Saw (aluminum blade) | 5. 5/16" drill bit | 6. 1/4" Masonry bit |
| 7. #3 Phillips bit | 8. Painter's Tape | 9. 50' Tape Measure |

PARTS IDENTIFICATION

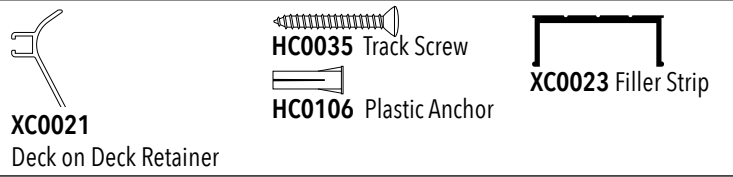

PREPARATION

1. Check pool measurements and take diagonal. Diagonal must be <2".
2. Gunite wall should be leveled to prepare for retainer. If the water's edge of gunite wall will be notched to lower retainer elevation, level the notch (do NOT fill in the notch).
3. Decide on gunite retainer overhang from pool walls. There is no need for overhang if tile is not installed before the retainer.

INSTALLATION

- Step 1** Starting at the end of the pool opposite the cover box, place (1) drilled 22' piece of Deck On Deck Retainer (XC0021) on the water side of the gunite wall. Make sure the end of the retainer extends 2" past the end wall. (The amount the retainer overhangs the water edge of pool wall is determined by pool requirements and design, especially tile selection.)
- Step 2** Use cordless drill with a 5/16" bit to drill a hole through the retainer. Then use hammer drill with a 1/4" masonry bit, drill through the hole in the retainer and into the wall approximately 2-1/2".
- Step 3** Locate the 1-3/4" Track Screws (HC0035) and Plastic Anchors (HC0106), move track and place an Anchor into each hole.
- Step 4** Move retainer back into position and twist the screw into each anchor through each hole in the retainer and lightly tap the screw with a hammer to set the anchor deeper into the hole, approximately 1/4" past top surface.
- Step 5** Tighten screws with #3 Phillips bit.
- Step 6** Continue drilling down the piece of retainer, until all holes are drilled and secured.
- Step 7** Lay the next piece of retainer on the wall, butting it up next to the retainer just installed.

Step 1

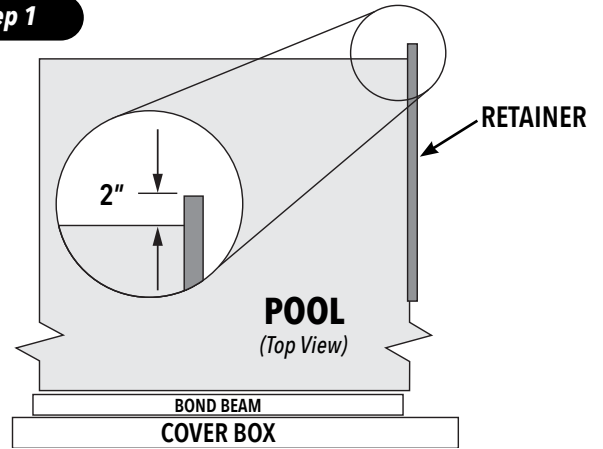

Step 2

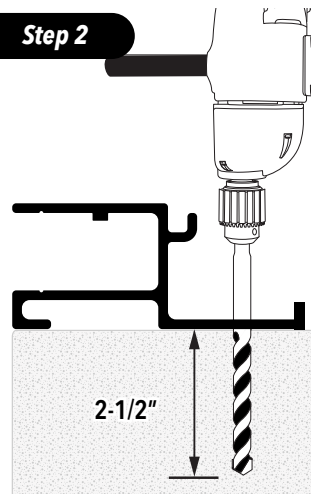

Step 4

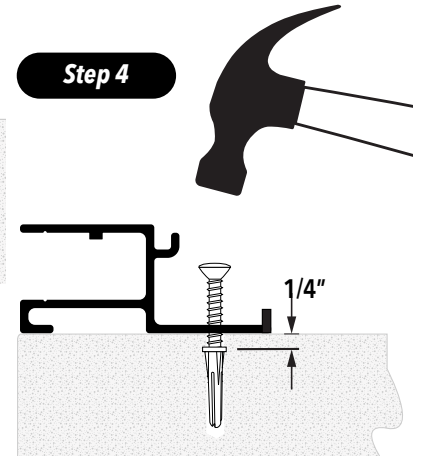

Step 5

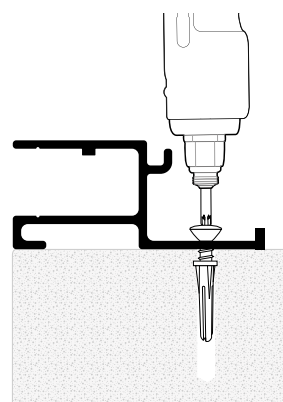

Step 7

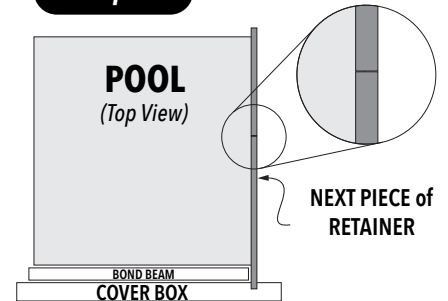

INSTALLATION (CONTINUED)

NOTE: To ensure the alignment of the retainer while the deck is being poured, Splice Kit KA0492 is available (sold separately) to insert at joints between the pieces of retainer.

Step 8 Retainer should extend into cover box 1". Use a straight edge and cut off excess retainer.

Step 9 Using a saw with an aluminum blade, cut a notch 1-1/2" on the top of the retainer so you will be able to secure the track during installation.

Step 10 Cut a notch on the back side the same distance as the cut made on the top.

Step 11 Drill and secure piece of retainer as in Step 3 and Step 4.

Step 12 Repeat steps 1-12 for the opposite side.

Step 13 Retainer will be installed next at the end of the pool opposite the cover box between the retainer pieces already installed. Measure the width between retainers and install retainer ensuring the corners are square where the retainers meet the retainer installed on each side of pool.

Step 14 To prevent concrete flowing in, create a temporary seal prior to deck pour or stone coping installation by taping off each opening at the end of the retainers using painter's masking tape. **Do not use any other form of tape.** (Does not apply if using reusable form.)

Step 15 Insert a piece of Filler Strip (XC0023) into the end retainer starting on one side. Measure the remaining space, then cut an appropriate piece of Filler Strip, and insert into the retainer.

Deck On Deck Retainer installation is complete.

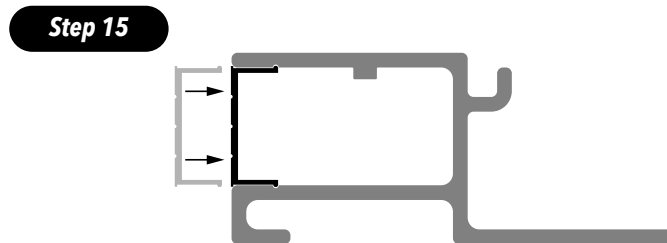
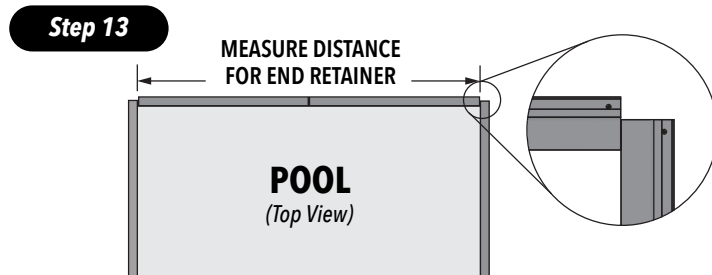
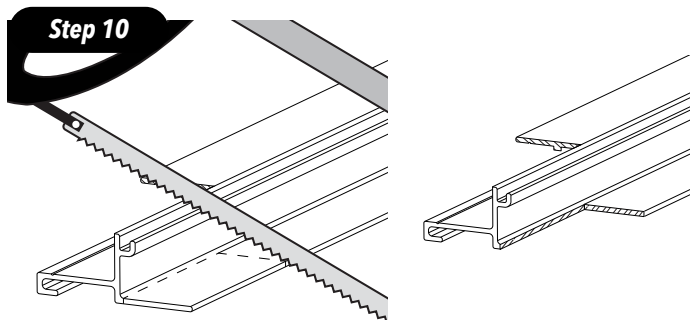
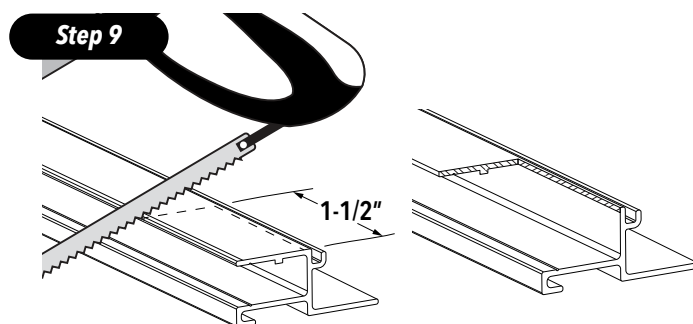
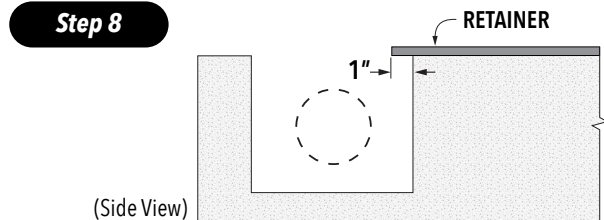
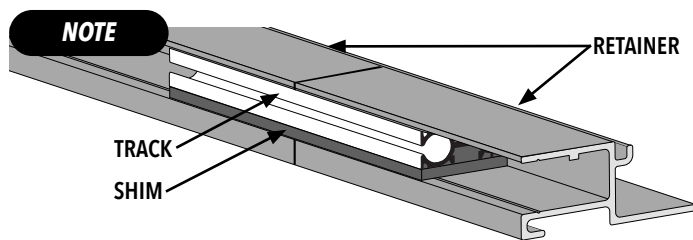

TECHNICAL SUPPORT

If you have any questions about these installation procedures, please contact Technical Support at (800) 878-5789.

Automatic Pool Covers, Inc.

(800) 878-5789 • automaticpoolcovers.com

TOOLS NEEDED

- | | | |
|-------------------------|--------------------|---------------------|
| 1. Cordless drill | 2. Hammer drill | 3. Hammer |
| 4. Saw (aluminum blade) | 5. 5/16" drill bit | 6. 1/4" Masonry bit |
| 7. #3 Phillips bit | 8. Painter's Tape | 9. 50' Tape Measure |

PARTS IDENTIFICATION

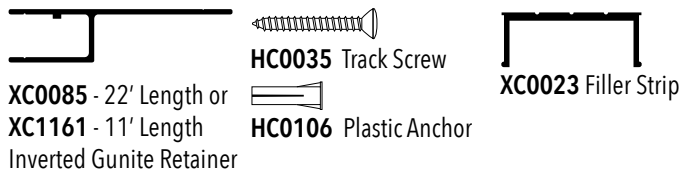

PREPARATION

1. Check pool measurements and take diagonal. Diagonal must be <math>< 2''</math>.
2. Gunite wall should be leveled to prepare for retainer. If the water's edge of gunite wall will be notched to lower retainer elevation, level the notch (do NOT fill in the notch).
3. Decide on gunite retainer overhang from pool walls. There is no need for overhang if tile is not installed before the retainer.

INSTALLATION

- Step 1** Starting at the end of the pool opposite the cover box, place (1) piece of drilled Inverted Gunite Retainer (XC0085 - 22' or XC1161 - 11') on the water side of the gunite wall. The retainer will extend down the face of the tile or tile area. If tile is not installed, overhang retainer to allow for tile to be installed.
- Step 2** Use cordless drill with a 5/16" bit to drill a hole through the retainer. Then use hammer drill with a 1/4" masonry bit, drill through the hole in the retainer and into the wall approximately 2-1/2".
- Step 3** Locate the 1-3/4" Track Screws (HC0035) and Plastic Anchors (HC0106), move track and place an Anchor into each hole.
- Step 4** Move retainer back into position and twist the screw into each anchor through each hole in the retainer and lightly tap the screw with a hammer to set the anchor deeper into the hole, approximately 1/4" past top surface.
- Step 5** Tighten screws with #3 Phillips bit.
- Step 6** Continue drilling down the piece of retainer, until all holes are drilled and secured.
- Step 7** Lay the next piece of retainer on the wall, butting it up next to the retainer just installed.

INVERTED GUNITE RETAINER

Installation Instructions

Step 1

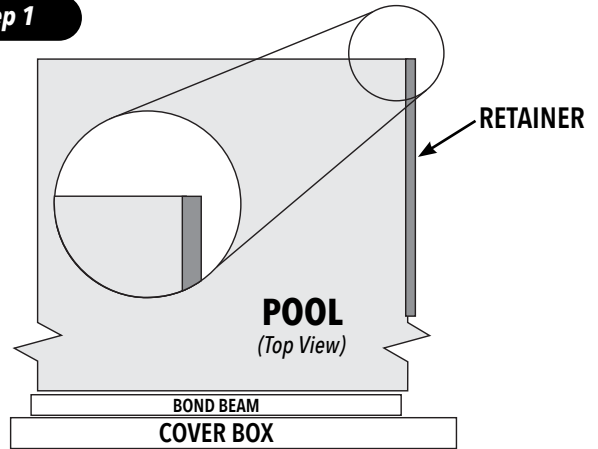

Step 2

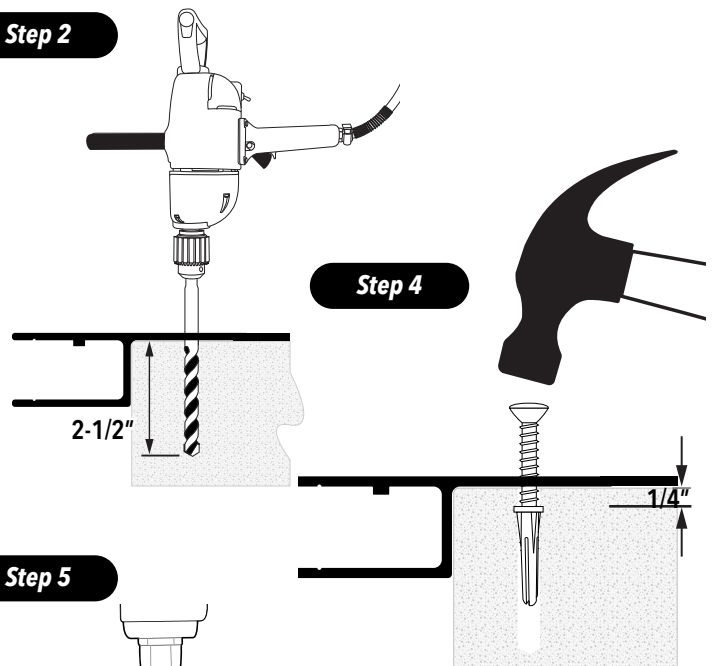

Step 5

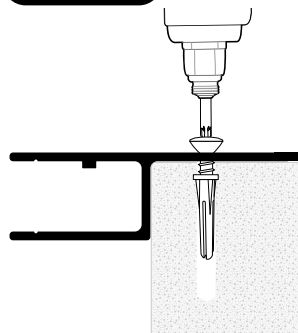

Step 7

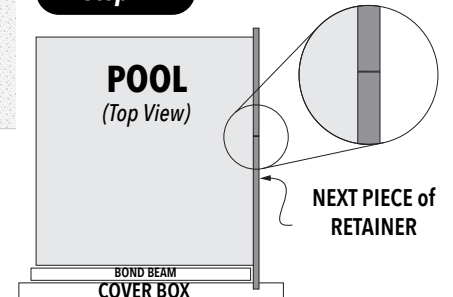

INSTALLATION (CONTINUED)

NOTE: To ensure the alignment of the retainer while the deck is being poured, Splice Kit KA0492 is available (sold separately) to insert at joints between the pieces of retainer.

Step 8 Retainer should extend into cover box 1". Use a straight edge and cut off excess retainer.

Step 9 Using a saw with an aluminum blade, cut a notch 1-1/2" on the top of the retainer so you will be able to secure the track during installation.

Step 10 Cut a notch on the back side the same distance as the cut made on the top.

Step 11 Drill and secure piece of retainer as in Step 3 and Step 4.

Step 12 Repeat steps 1-12 for the opposite side.

Step 13 If determined desirable, next install retainer at the end of the pool opposite the cover box between the retainer pieces you already installed. Measure the width between retainers and install retainer ensuring the corners are square where the retainers meet the retainer installed on each side of the pool.

Step 14 To prevent concrete flowing in, create a temporary seal prior to deck pour or stone coping installation by taping off each opening at the end of the retainers using painter's masking tape. **Do not use any other form of tape.** (Does not apply if using reusable form.)

Step 15 Insert a piece of Filler Strip (XC0023) into the end retainer starting on one side. Measure the remaining space, then cut an appropriate piece of Filler Strip, and insert into the retainer.

Inverted Gunite Retainer installation is complete.

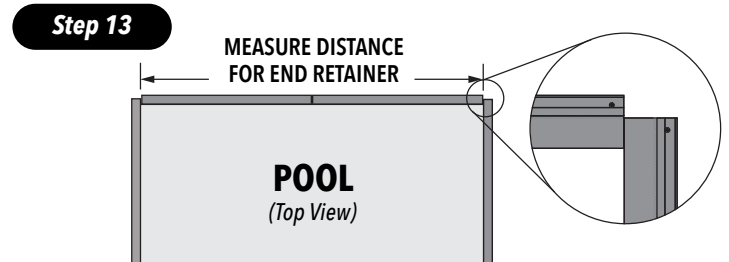
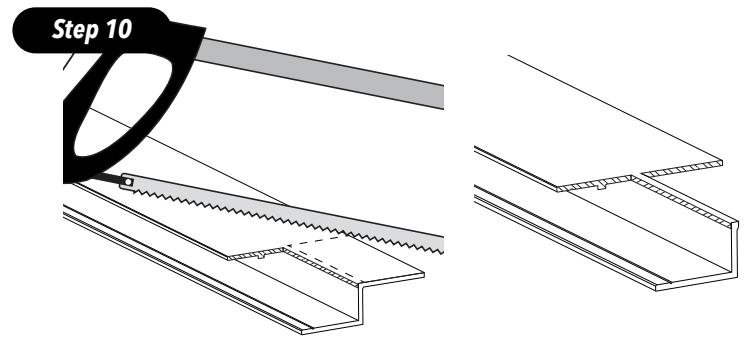
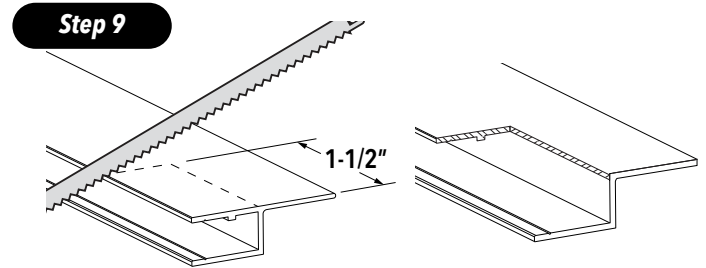
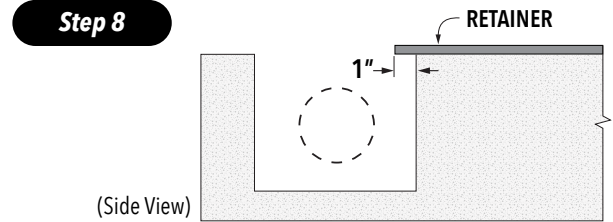
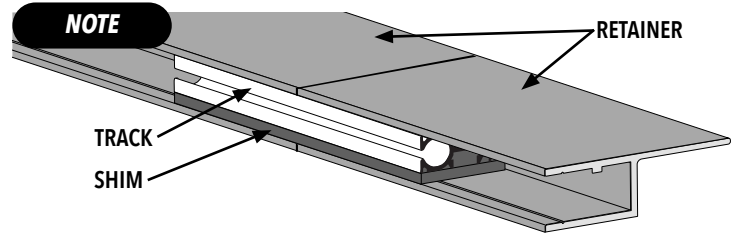

TECHNICAL SUPPORT

If you have any questions about these installation procedures, please contact Technical Support at (800) 878-5789.

Automatic Pool Covers, Inc.

POLYMER BOX INSTALLATION

Top Track Instructions

TOOLS NEEDED

- | | | | |
|-------------------|----------------------|---|------------------------------|
| 1. Cordless drill | 2. 12" Torpedo level | 3. Wrenches/sockets: 7/16", 1/2", 9/16" | 4. Saw (with aluminum blade) |
|-------------------|----------------------|---|------------------------------|

INSTRUCTIONS

1. Start with the 6' poly box section with drain hole and set it to the determined motor side. A 1' set back from the waters edge is recommend but do not go more than 2' d
2. With the box set in place, locate the 2 polymer box stake brackets, 3/8" unistruts, and 3/8" x 0.75" bolts and insert the unistrut into the back channel of the polymer box rail at the front and back side of the poly box and secure the poly box stake brackets with the 3/8" x 0.75" bolt.
3. Locate the polymer box splice and insert it into the poly box rail at the front and back side of the poly box.
4. Locate the next opened end 6' poly box section and nest the non-flanged end to the flanged end of the first poly box section and slide over the poly box splice so it is equal with both sections of poly boxes and secure each section with two 3/8" x 0.75" bolts.
5. Repeat steps 2-3 and slide the poly box splice over so it is equal with both sections of polymer boxes and secure each section with two 3/8" x 0.75" bolts.
6. Depending on the track space, another opened end 6' poly box section may be required. If so, start with step 4 followed by steps 2-3. If not proceed to step 7.
7. To ensure the polymer box keeps its form while the concrete is poured, insert the box supports in the top rails of the polymer box. Insert 2 box supports in each section of polymer box.

Step 1

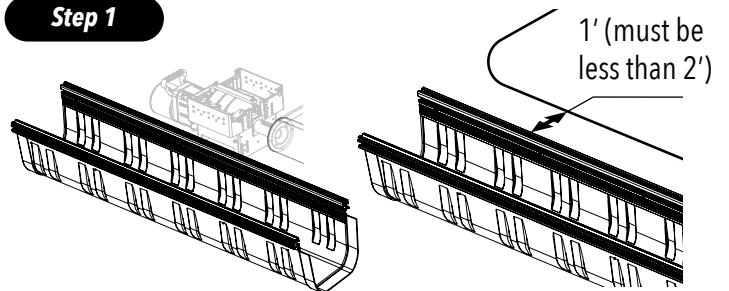

Step 2

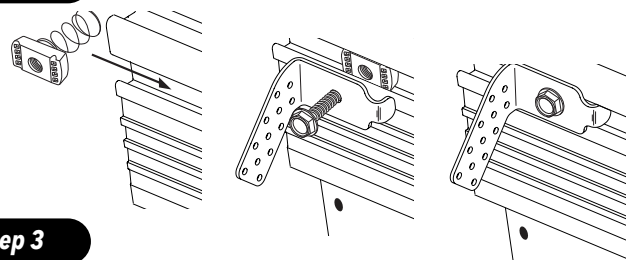

Step 3

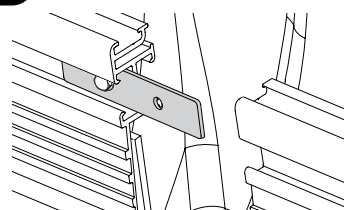

Step 4

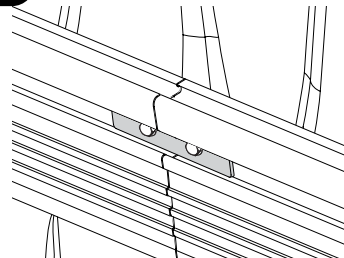

Step 7

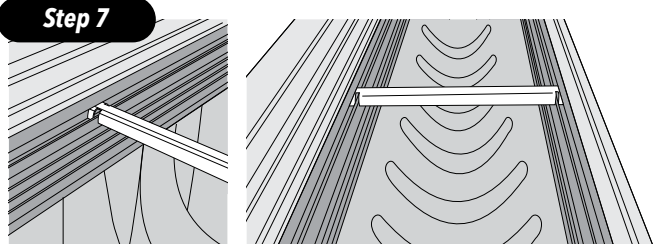

INSTRUCTIONS (CONTINUED)

8. Install the polymer box that has the end cap already installed. Nest the non-flanged end to the flanged end of the last polymer box section that was just installed.
9. Repeat step 5.
10. Starting at the motor end, line up the black mark where the track edge will be at and square up the box with the pool.
11. Locate two 4' sections of wood stakes and line it up with the stake bracket and drive them into to backfill.
12. Raise the poly box to the finished deck height and secure the wood stake to the poly box stake bracket with screws or nails.
13. Continue on to each polymer box stake bracket and repeat step 10-12.
14. Double check to make sure that the entire box is set to the finished deck height and level front to back and is square with the pool.
15. Trim off the top of each wood stake below riser so there is no interference when the concrete is poured.

Step 8

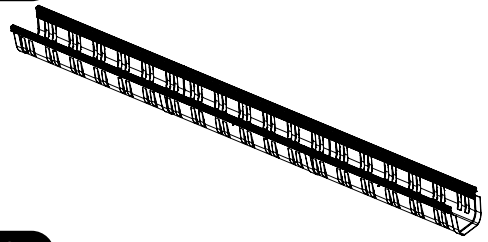

Step 10

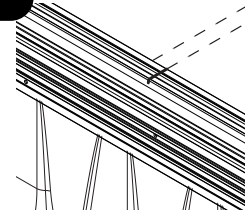

Mechanism End

Step 11

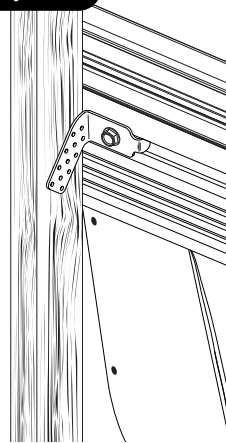

Step 12

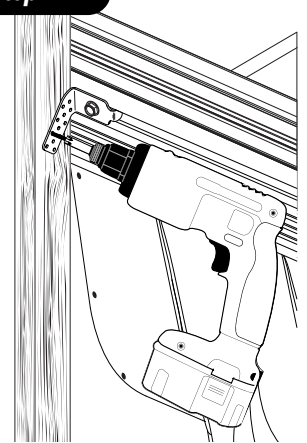

Step 12

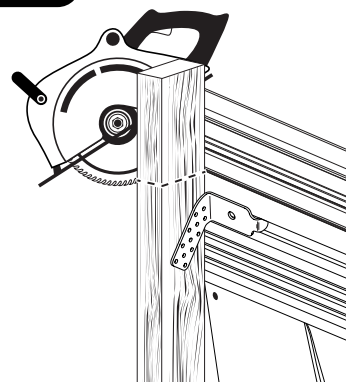

TECHNICAL SUPPORT

If you have any questions about these installation procedures, please contact Technical Support
(800) 878-5789 Monday through Friday, 8 am - 5 pm EST.

Automatic Pool Covers^{Inc.}

(800) 878-5789 • automaticpoolcovers.com

POLYMER BOX INSTALLATION

Recessed Under Track w/Flush Lid Instructions

TOOLS NEEDED

1. Cordless drill 2. 12" Torpedo level 3. Wrenches/sockets: 7/16", 1/2", 9/16" 4. Saw (with aluminum blade)

INSTRUCTIONS

1. Start with the 6' polymer box section with drain hole and set it to the determined motor side. A 1' set back from the waters edge is recommend but do not go more than 2' d
2. With the box set in place, locate the 2 polymer box stake brackets, 3/8" unistruts, and 3/8" x 0.75" bolts and insert the unistrut into the back channel of the polymer box rail at the front and back side of the poly box and secure the polymer box stake brackets with the 3/8" x 0.75" bolt.
3. Locate the poly box splice and insert it into the polymer box rail at the front and back side of the poly box.
4. Locate the next opened end 6' poly box section and nest the non-flanged end to the flanged end of the first polymer box section and slide over the poly box splice so it is equal with both sections of polymer boxes and secure each section with two 3/8" x 0.75" bolts.
5. Repeat steps 2-3 and slide the polymer box splice over so it is equal with both sections of polymer boxes and secure each section with two 3/8" x 0.75" bolts.
6. Depending on the track space, another opened end 6' polymer box section may be required. If so, start with step 4 followed by steps 2-3. If not proceed to step 7.
7. Install the polymer box that has the end cap already installed. Nest the non-flanged end to the flanged end of the last polymer box section that was just installed.

Step 1

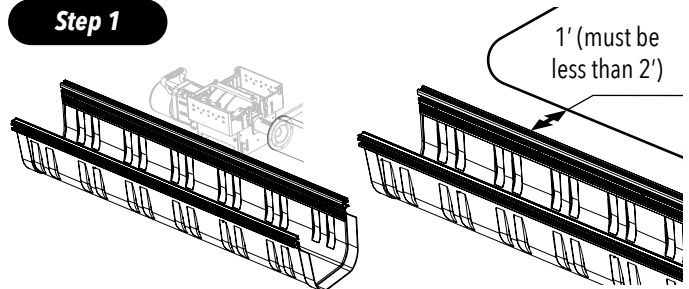

Step 2

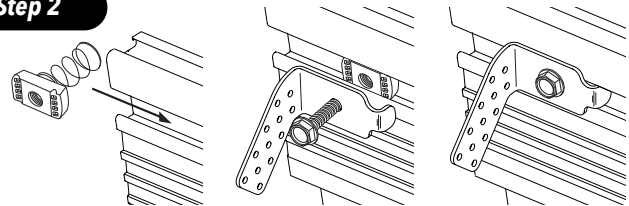

Step 3

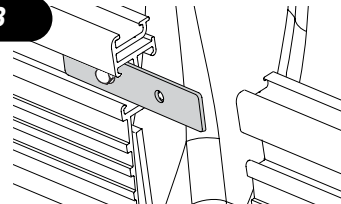

Step 4

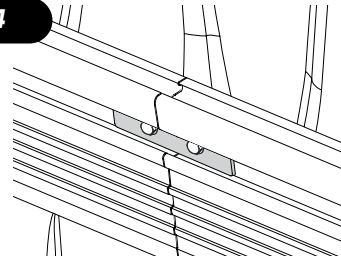

Step 7

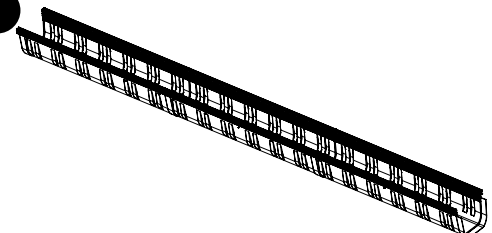

INSTRUCTIONS (CONTINUED)

8. Install the polymer box spacer brackets throughout the width of the polymer box so it maintains the appropriate inside dimension.
9. Repeat step 5.
10. Starting at the motor end, line up the black mark on the rail on the polymer box with the inside edge of the retainer that is set for the track space.
11. Locate the 8" riser and place it on the front side of the poly box, beside the edge of the retainer. Secure with 1/2" Tek screws at each end.
12. Locate the other riser end plate and fasten it to the riser through the pre-drilled holes and into the channels of the riser with 1" Tek screws.
13. Locate one of the full lengths of riser and place it on the back side of the poly box so that the riser end plate forms 90 degrees to both the front and back riser sections. Secure with the 1/2" Tek screws 18" apart.
14. Locate the 2'8" section of riser and place it on the front side of the poly box beside the edge of the retainer. The riser will nest into the poly box rail. Secure with 1/2" Tek screws at each end.
15. Locate the riser end plate and fasten it to the riser through the pre-drilled holes and into the channels of the riser with 1" Tek screws.

Step 21

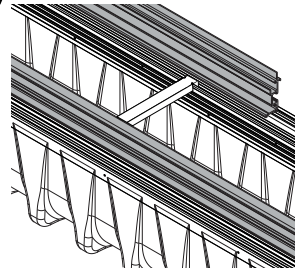

Step 9

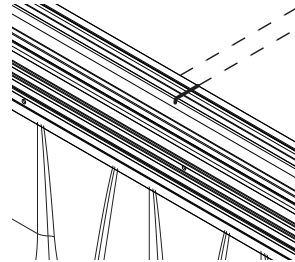

Step 10

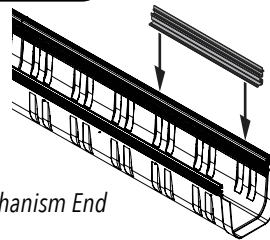

Mechanism End

Step 11

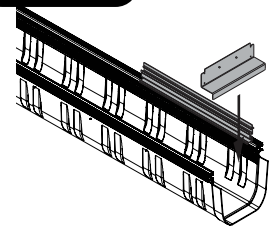

Mechanism End

Step 12

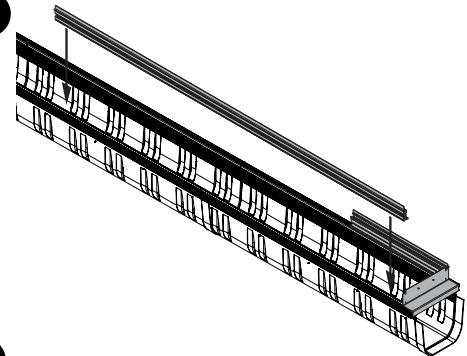

Step 13

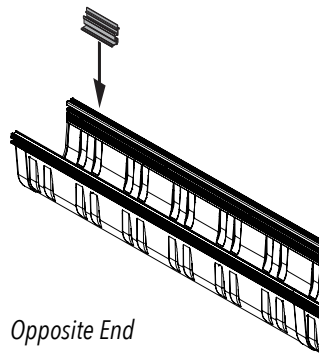

Opposite End

Step 14

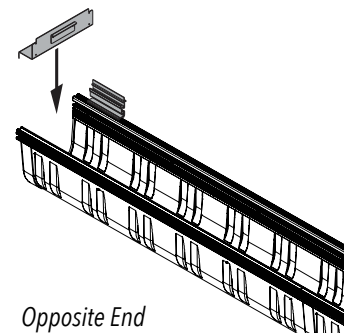

Opposite End

INSTRUCTIONS (CONTINUED)

Step 16 With the riser end plate squared, mark a line on the polymer box rail and measure the distance from there to the already installed riser on the back of the polymer box.

Step 17 Cut the last piece of riser to size (*) and secure it with the 1/2" Tek screws every 18".

Step 18 Go to the motor side to start to level and secure the polymer box.

Step 19 Locate two 4' sections of wood stakes and line them up with the stake bracket and drive them into the backfill. There will be 4 stakes per polymer box section.

Step 20 Make sure that the polymer box with riser is set to the finished deck height and secure the wood stake to the polymer box stake bracket with screws (not included).

Step 21 Continue to each polymer box stake bracket and repeat step 19-20.

Step 22 Double check to make sure that the entire box is set to the finished deck height, level front to back, and is square with the pool.

Step 23 Trim the top off of each wood stake below the riser so there is no interference when the concrete is poured.

Step 15

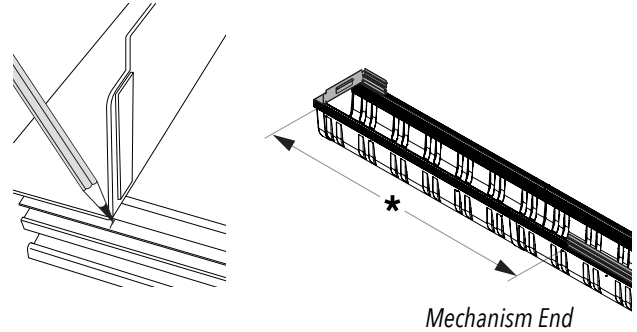

Step 16

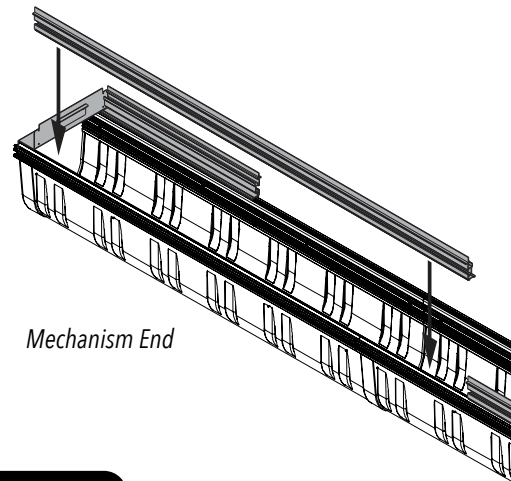

Step 18

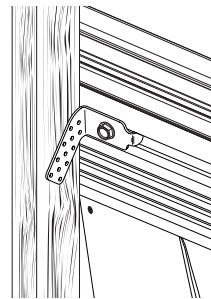

Step 23

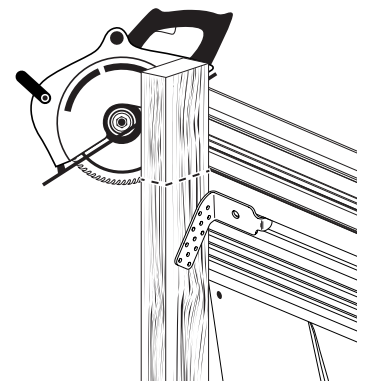

TECHNICAL SUPPORT

If you have any questions about these installation procedures, please contact Technical Support (800) 878-5789 Monday through Friday.

Automatic Pool Covers, Inc.

(800) 878-5789 • automaticpoolcovers.com

RISERS AND EXTENSIONS

Specifications & Instructions

OVERVIEW

The Risers and Extensions are a part of the system that supports an APC Flush Lid, stones, pavers, or other materials. Risers and Extensions can be used together to achieve the necessary height so the lid will be at the same height as the pool deck.

SPECIFICATIONS

- | | |
|---|---|
| <p>A Polymer Box Rail
Factory installed on Polymer Box to which the Riser is secured.
XC 0040</p> | <p>D 3/8" Extension Riser
Allows for Additional 3/8"
XC1158 - 10'-2" L</p> |
| <p>B Stone Lid Riser
MC1002 - 2'-8" L
MC1003 - 0'-8" L
MC1017 - 6'-1" L
XC1138 - 12'-2" L</p> | <p>E THREE-SIXTY-FIVE Lid Riser
XC1050 - 0'-8" L
XC1051 - 2'-8" L
XC1052 - 10'-2" L
XC1053 - 12'-2" L</p> |
| <p>C 1" Extension Riser
Allows for Additional 1"
XC1094 - 10'-2" L</p> | |

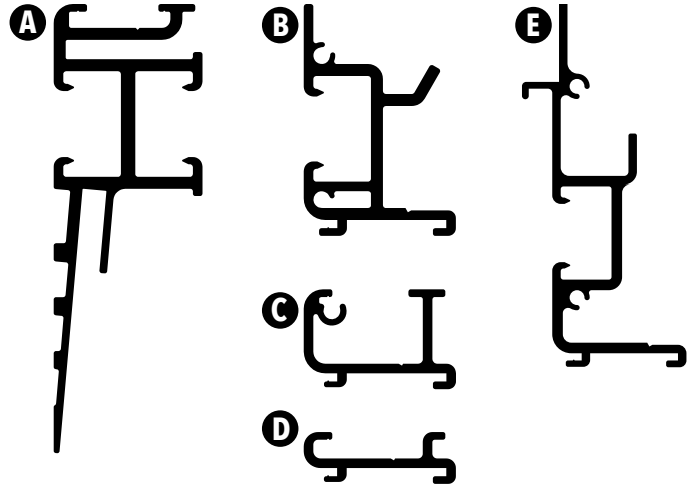

INSTRUCTIONS

- Step 1** Set Riser or Extension on the Box Rail so the hooks on the bottom of the Riser face the inside of the Polymer Box.
- Step 2** Slide the Riser or Extension toward the inside of the Polymer Box until the faces of the Box Rail, or other Riser, are flush.
- Step 3** Secure the Riser or Extension in place by inserting a 1/2" self-tapping (Tek) screw (HC 0213) at the notch in the Riser at a slight angle using a cordless drill with a 5/16" socket.
- Step 4** Screw should be inserted down through the riser as shown. The screw helps secure the interlocking design of the Riser. Insert screws at both ends of each piece of Riser and throughout the middle.

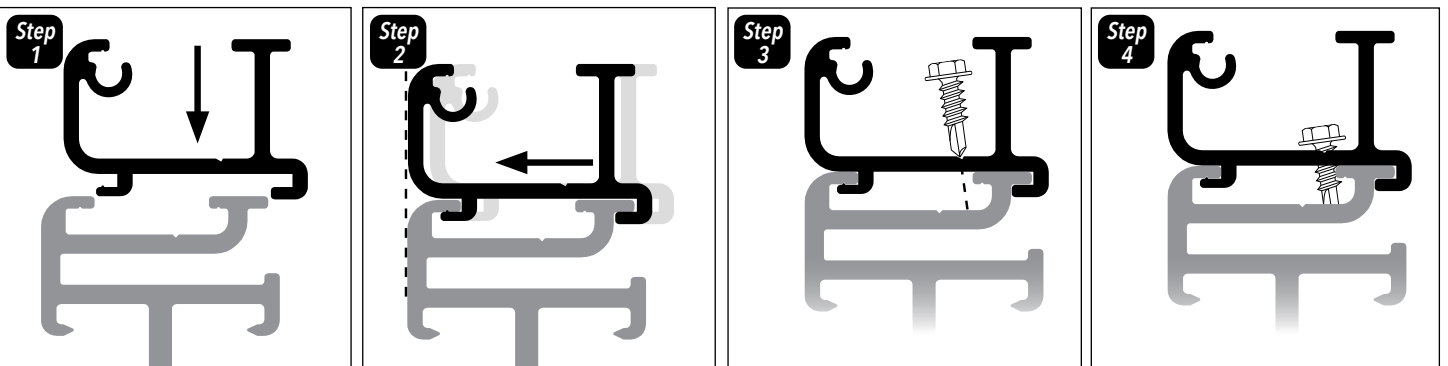

TECHNICAL SUPPORT

If you have any questions about these installation procedures, please contact Technical Support at (800) 878-5789

POLYMER BOX LID RISERS

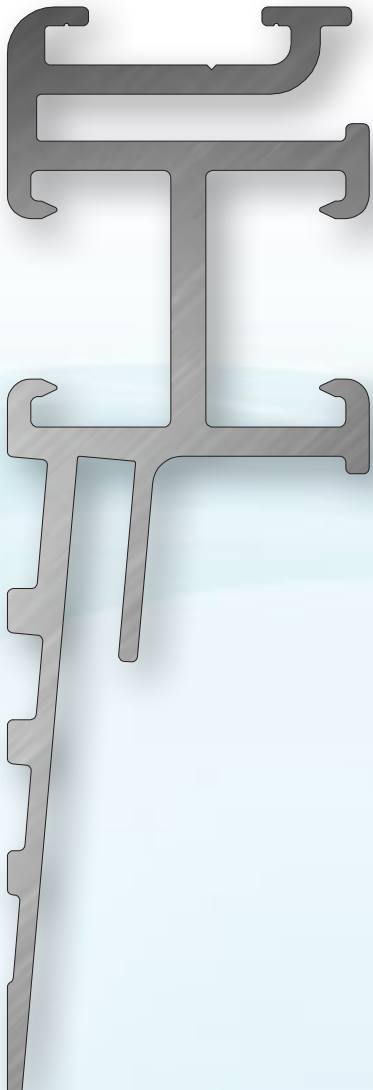

BOX RAIL
Factory Installed to the
Polymer Box to which the
Riser is Secured

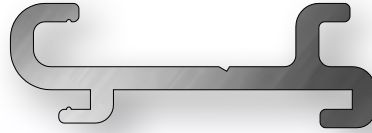

3/8" EXTENSION
Allows for Additional 3/8"

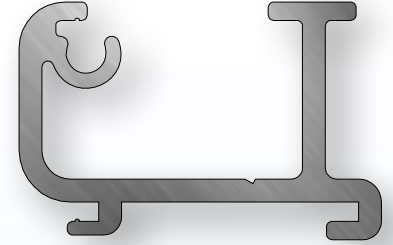

1" EXTENSION
Allows for Additional 1"

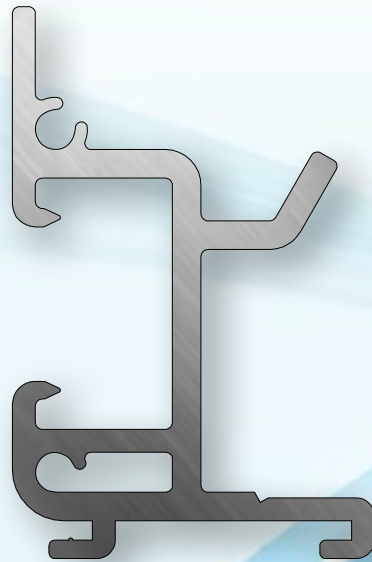

STONE LID RISER
Allows for 1-3/4" Stone

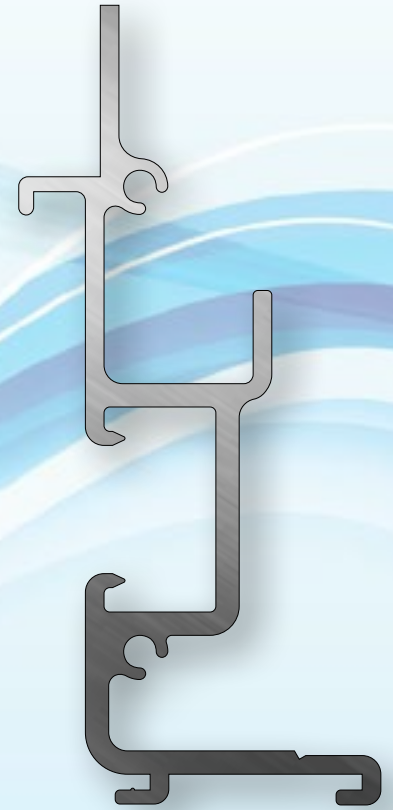

THREE-SIXTY-FIVE

- ***Supports an APC Flush Lid, Stones, Pavers, or Other Materials***
- ***Use Together to Match the Pool Deck***

ADJUSTABLE FLUSH LID RISER

AFLR Installation Instructions

TOOLS NEEDED

- | | | | |
|----------------------------------|----------------------------------|-----------------|---|
| 1. Wrenches/Sockets: 1/2", 9/16" | 2. Screw Drivers: Flat, Phillips | 3. Circular Saw | 4. String Line |
| 5. Hammer Drill | 6. Level | 7. Square | 8. Drill Bits: 1/4", 3/8", 5/16" Nut Driver |
| 9. 50' or 100' Extension Cord | 10. Hacksaw | 11. Metal File | 12. Jig Saw |

IT IS RECOMMENDED THAT 2 PEOPLE COMPLETE THIS INSTALLATION

TERMS

Motor End - Side that will house the mechanism/motor. This side extends further out from pool side than non-mechanism end. (Mechanism may be on either end of housing.)

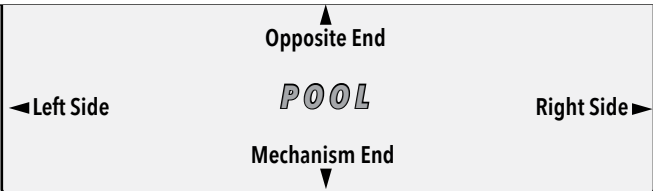

Non-Motor End - End that houses the non-motorized portion of the mechanism.

Housing - Where the motor and mechanism are contained and the cover rolls up

Retainer (Encapsulation) - Straight pieces of extruded aluminum that accept the track and vinyl liner.

Mechanism End - End of the pool that contains the housing and cover.

Riser - Extruded aluminum pieces around the housing that support the lid.

Opposite End - End of pool across from the Mechanism End.

TERMS

ADJUSTABLE FLUSH LID RISER (AFLR)

- XC1007 3'-0" used on motor end
- MC1008 1'-0" used on non-motor end
- MC1131 12'-2" used on back of housing

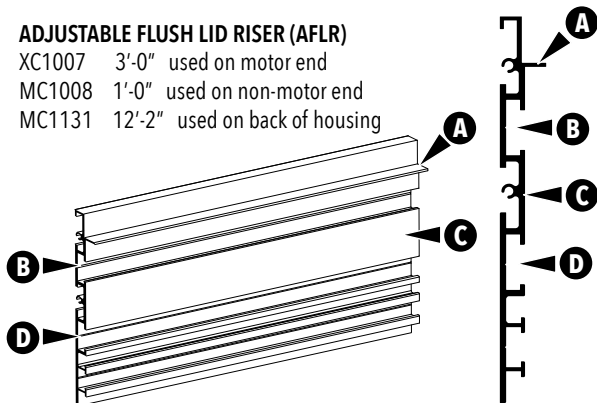

- A** Lid Tab that lid rests on.
- B** Top Channel
- C** This side faces the inside of the housing.
- D** Bottom Channel

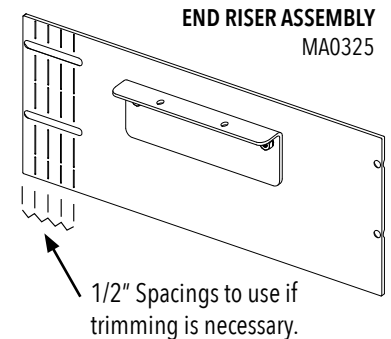

HD3 CHANNEL PLATE
MC0348

BOX RAIL SPLICE
MC0787

TURNBUCKLE
MA0329

TURNBUCKLE CLIP
MC0998

HD2 GEN II BRACKET KIT
KA0338

5" LAG BOLT
HC0037

#12 X 1-1/2" PH
HC0037

3/4" BOLT
HC0174

3/4" TEK SCREW
HC0387

PLASTIC ANCHOR
HC0106

5/16" NUT
HC0057

PREPARATION

Prep A To prepare the track and retainer for the AFLR installation, with metal hacksaw cut notch out of the retainer 1" from the end.

Prep B Repeat Prep A on opposite end of housing.

Prep C **IMPORTANT:** The front to back ID of the housing must be 14" or less. Measure the housing from front to back. If the ID measurement is GREATER than 14", attach wood (or some other available sturdy material) that is the thickness of the discrepancy to the back of housing so the ID equals 14" (no smaller than 12"). The material will be attached to the top of the housing, the fill length of the housing, and should be as tall as the riser. Use a string line to ensure the adjusted thickness is straight across the back of the housing.

NOTE: Housing that is less than 14" will require cuts to be made to the lid.

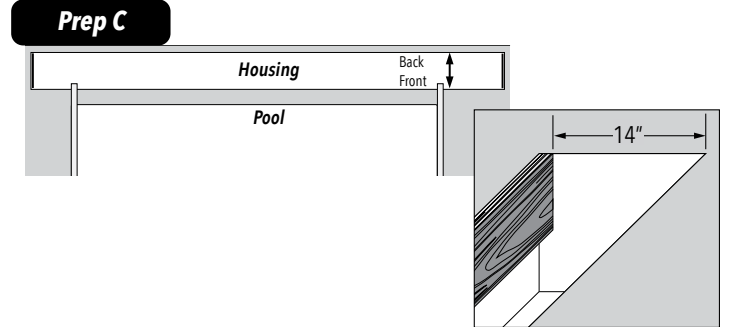
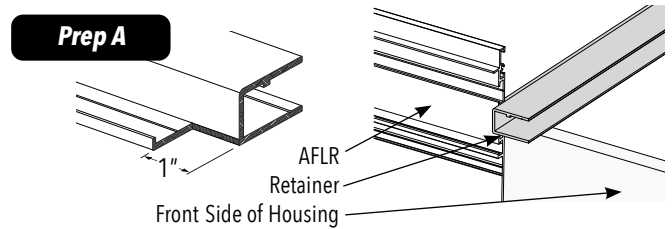

INSTRUCTIONS

IMPORTANT: Build recessed housing 3' ID longer on the motor end, 1' ID longer on the non-motor end, and 14" ID width. (E.g. Track Width + 3' + 1' = Housing Length ID)

IMPORTANT: The housing should extend no more than 3' past the side of the pool edge on the Motor End and 1' past on the Non-Motor End. Materials, such as riser and lid, are supplied to accommodate these measurements. If the housing sides are longer than outlined, there may not be enough material.

NOTE: Failure to build housing to these specifications may result in insufficient material to complete job.

Step 1 Beginning from the front side (closest to the pool) of the motor end of the housing, determine the cut size of the AFLR by measuring the distance from the retainer to the end of the housing. Subtract 1/8" for the End Riser Assembly (MA0325) thickness.

Step 2 Locate the 3'-0" section of AFLR (MC1007) and make the necessary cut according to the previous measurement.

Step 3 Pre-drill the AFLR with 1/4" drill bit to secure to housing. Drill holes 2" in from each end along the etched line in the bottom channel. Then drill holes approximately every 3'.

Step 4 If housing is less than 14" (front to back), the End Riser Assembly can be trimmed. Each guideline indicates 1/2". If necessary, cut along the appropriate guideline with circular saw. **NOTE:** Housing that is less than 14" will require cuts to be made to the lid.

Step 5 Outside of the housing, assemble the cut piece of the Riser and a 12'-2" length of AFLR (XC1131) to the End Riser Assembly (MA0325). With the Lid Support Tab of the End Riser facing toward the inside of the assembly, insert Screw (HC0387) through hole in End Riser, then into the "C" channels in the AFLR.

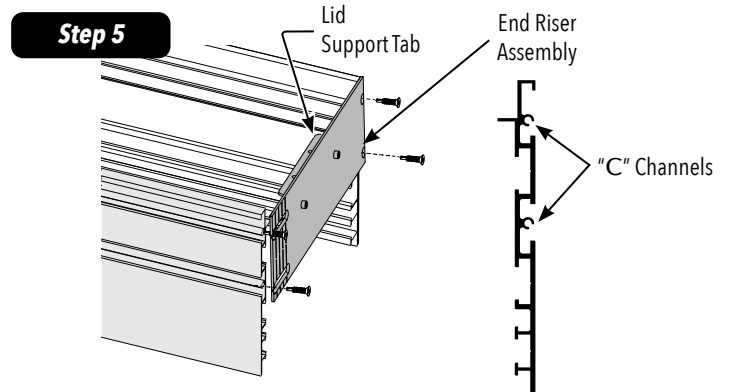
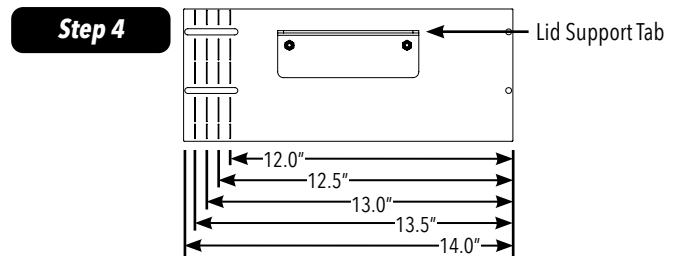
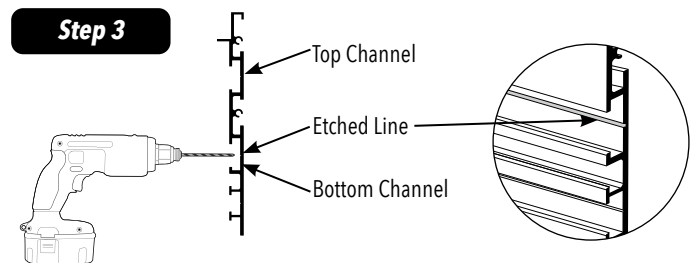
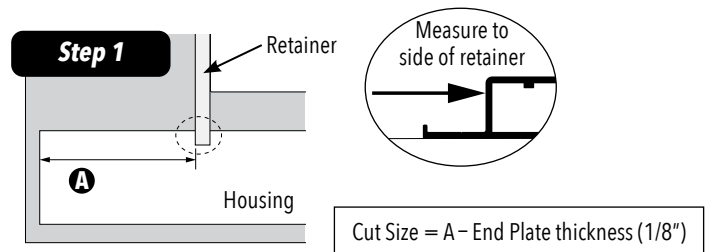

INSTRUCTIONS

Step 6 Determine the necessary finished height of the Riser by lowering the Riser assembly into the housing, and adjusting height so it will be flush with the pool deck.

Pro's Tip To insert the Plastic Anchor (HC0106) into the concrete, drill a hole with 1/4" bit then partially screw the HC0037 into the Plastic Anchor then gently tap the screw through the hole. When the anchor is flush with the AFLR, screw the HC0037 until it is secure.

Step 7 For Wood Housing: hold assembly in place and screw through the predrilled holes in AFLR and directly into wood with HC0037.

For Concrete Housing: hold assembly in place and mark location where screw should go, set Riser assembly aside. Drill 1/4" hole and insert Plastic Anchor (HC0106). Lower assembly back in place and attach with screw (HC0037).

Step 8 Repeat procedure for Non-Motor End.

Step 9 With both ends of the assembly installed, measure the remaining space between the one end of the installed AFLR to the other end.

Step 10 Cut a piece of AFLR (XC1131) to the length measured in Step 9 with a circular saw.

Step 11 Use a string line, level along the backside of the box from the end plate to ensure the entire length of AFLR is level and straight.

Step 12 Align and secure the cut piece as instructed in Step 7.

Step 13 Ensure the front and back sides of AFLR are square and level.

Step 14 To join and secure the risers, at each place where the risers meet along the back side of the housing, install a Box Rail Splice (MC0787) into the bottom channel of the AFLR. Tilt the Plate, slide it up into channel, rotate and let it rest in place.

Step 15 Secure Box Rail Splice using 3/4" bolts (HC0174).

Step 16 At each splice secured in Step 14, insert an HD2 Channel Plate (MC0348) into the top channel. Tilt the Plate, slide it up into channel, rotate and let it rest in place.

Step 17 On each HD Channel plate installed in Step 16, install an HD2 Gen II Bracket (KA0338) using Bolt (HC0174) into HD2 Channel Plate (MC0348.) Attach bracket in the lowest position, then adjust so top of bracket is level with the Lid Tab in the AFLR that the lid rest on.

Step 18 In addition to installing a HD2 Gen II Bracket at Riser splice(s), install additional HD2 Gen II Brackets every 2' - 3' as instructed in Step 17.

Pro's Tip To make it easier to screw the Bracket into the HD Channel Plate, wedge a flat-head screw driver behind the end of the HD Channel Plate. This will force the HD Channel Plate forward making the it easier to start the bolt.

Step 6

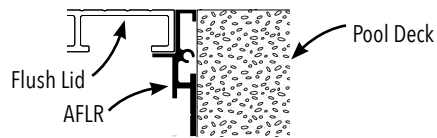

Pro's Tip

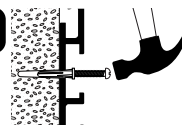

Step 9

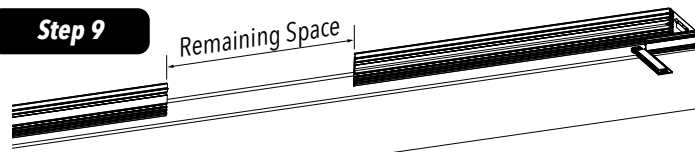

Step 13

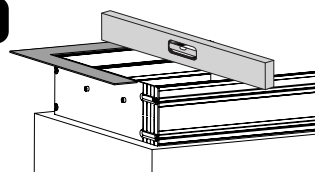

Step 14

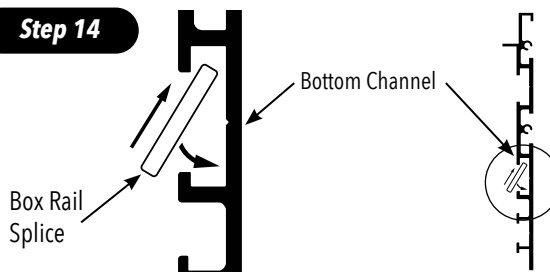

Step 16

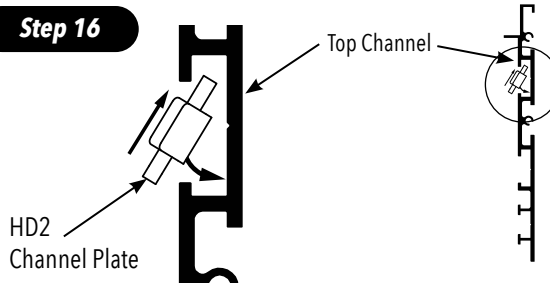

Step 17

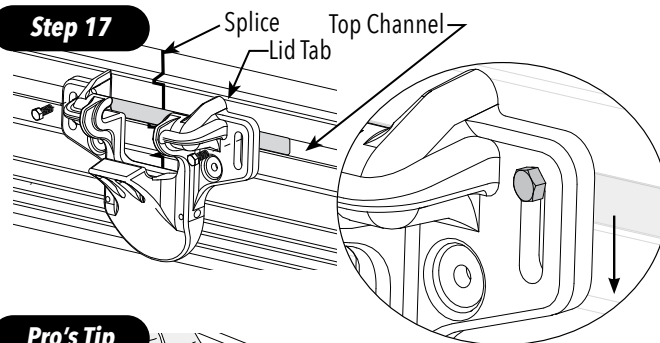

Pro's Tip

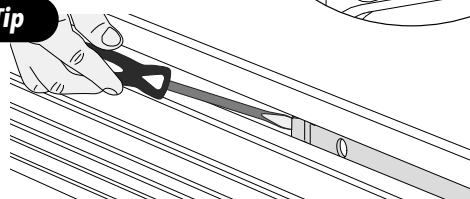

INSTRUCTIONS

Step 19 If deck is poured concrete, provide additional support while concrete sets by attaching 5" Carriage Bolt (HC0392) into AFLR. Drill 3/8" holes on both sides of HD2 Gen II Lid Bracket. Screw a Nut (HC0057) partially onto the bolt, insert into the drilled hole, then secure with second Nut (HC0057). Be sure that bolt doesn't extend past the side of the riser. If bolt extends past the riser, it might rip the cover.

Step 20 To determine the cut length of the Main Lid, measure from the Non-Motor End to 6" past the front edge of Motor End Retainer.

Pro's Tip For the most clean cuts when using a chop saw or circular saw, make slow, gentle cuts.

Step 21 Make necessary cut on the end of the Main Lid that will butt up against the Riser End Plate of the Non-Motor End. The orientation of the cut on the Main Lid (with the cut made on the End Lid in Step 23) will allow factory-cut ends to meet.

Step 22 To determine the cut length of the Motor End Lid, first place the cut Main Lid in place. Measure the distance from the edge of the Main Lid to the Riser End Plate of the Motor End. Allow 1/16" gap for expansion.

Step 23 Make necessary cut on the Motor End Lid that will butt up against the Riser End Plate of the Motor End. The orientation of the cut on the Main Lid and Motor Lid will allow factory-cut ends to meet.

Step 24 If the front-to-back ID of the housing is less than 14", the lids will need to be cut. Subtract the ID from the width of the lid (13") and on both ends, carefully cut notches that measurement from the outside of the riser with a hacksaw. Then cut across to the end with a circular saw. Cut the same dimension across the Motor End Lid. File cut surfaces to remove rough edge.

Step 25 Install Lid Seam Support Bracket (KA0286) per instructions enclosed with kit. **NOTE:** A motor is shown in illustrations for orientation purposes. The mechanism will be installed later in the installation process.

Step 26 Turnbuckles (MA0341) have been supplied to insure the AFLR is kept in the correct position as pool construction continues. Locate the Turnbuckles, and lay them out according to the illustration.

A Non-Motor End: 1 centered between on width of AFLR cut for Non-Motor End

B Bond Beam: 4 Turnbuckles spaced evenly or where needed in area between the two pieces of cut AFLR

C Motor End: 1 centered between on width of AFLR cut for Motor End

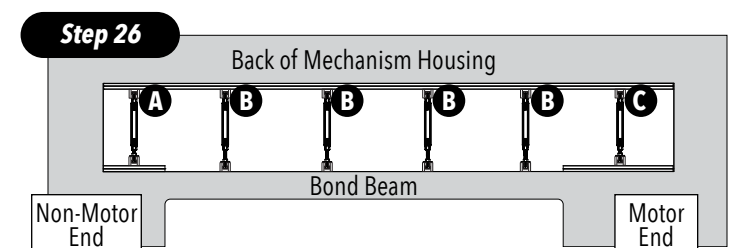
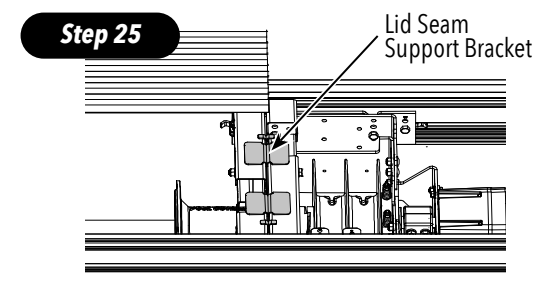
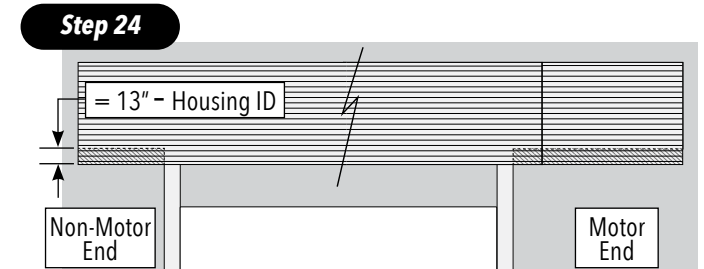
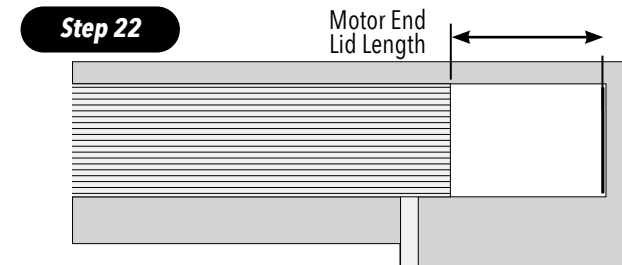
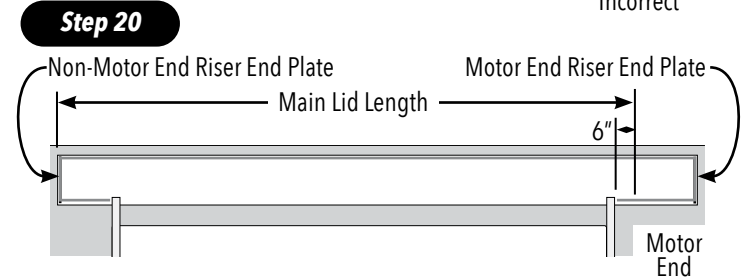
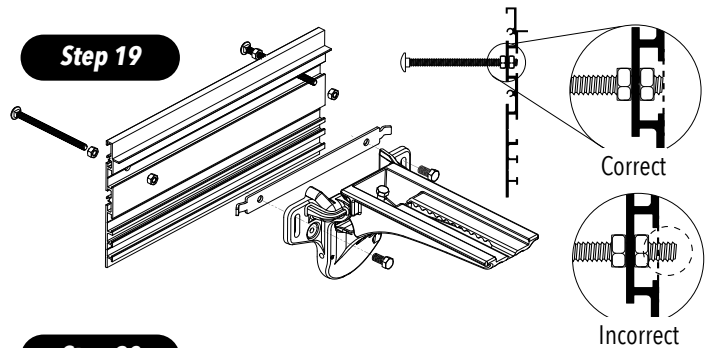

INSTRUCTIONS

IMPORTANT: The ends of the Turnbuckle are threaded oppositely. One end has left-hand threads (tightens counter-clockwise) and the other has right-hand threads (tightens clockwise). For orientation purposes, identify these ends, and install the left-hand threaded end in the back side of the Mechanism Box. The orientation for instructions regarding twisting the Turnbuckle are based on looking from the back side of the box.

Step 27 Install the Turnbuckles on the **A** Non-Motor End and the **C** Motor End by inserting the left-hand threaded end into the top channel of the AFLR in the back side of the Mechanism Box. Turn Head so it anchors within the channel. Tighten the nut until it and the washer are tight against the AFLR.

Step 28 Insert the other end of the Turnbuckle into the top channel of the AFLR in the front side of the Mechanism Box. Turn Head so it anchors within the channel. Tighten nut until it and the washer are tight against the AFLR.

Step 29 Install the left-hand threaded end of Turnbuckles into the top channel of the AFLR in area **B** between the Non-Motor End and Motor End into the top channel of the AFLR on the back of the Mechanism Box. Space the Turnbuckles evenly along the expansion. Turn Head so it anchors within the channel. Tighten the nut until it and the washer are tight against the AFLR.

Step 30 The opposite end of Turnbuckle will be secured to area along the Bond Beam with a Turnbuckles clip (MC0998) as shown. From the end, measure the distance to the Turnbuckle installed in the AFLR on the backside of the Mechanism Box. On the front side of the box, transfer that measurement across to the Bond Beam, then make a mark 3" down from the top of the Bond Beam.

Pro's Tip When inserting the Plastic Anchor (HC0106) into the Bond Beam, partially screw the screw (HC0037) into the Plastic Anchor. Put the Turnbuckle Clip in place and gently tap the screw through the hole. When the anchor is flush with the concrete, screw the HC0037 until it is secure.

Step 31 Drill a 1/4" hole into the Bond Beam at the mark and insert a Plastic Anchor (HC0106). Align the Turnbuckle Clip and attach with Screw (#12X 1-1/2" PH - HC0037)

Step 32 Slide the end of the Turnbuckle down into the Clip. Tighten the nut until it and the washer are tight against the AFLR.

Step 35 To draw (tighten) the AFLR together, twist the center of the Turnbuckle CLOCKWISE. To expand the AFLR, twist the center of the Turnbuckle COUNTER-CLOCKWISE.

Step 27

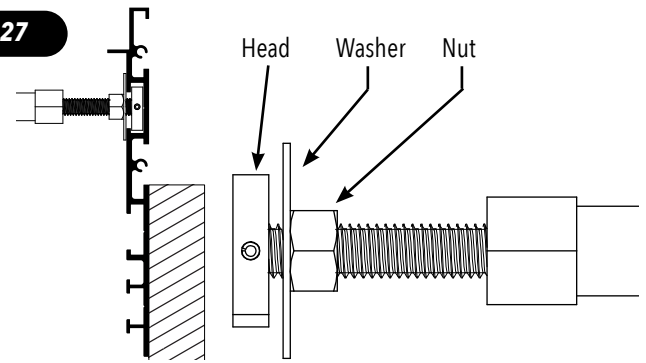

Step 28

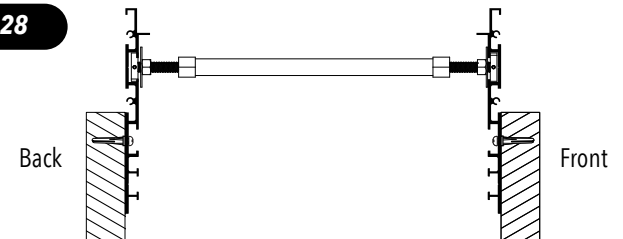

Step 30

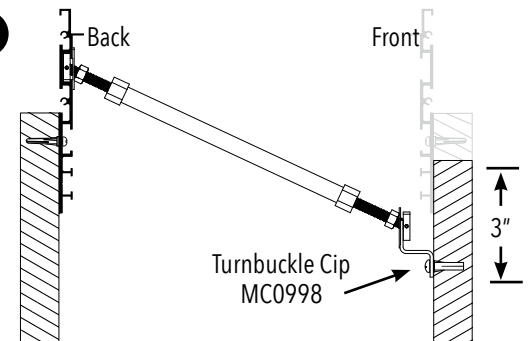

Step 32

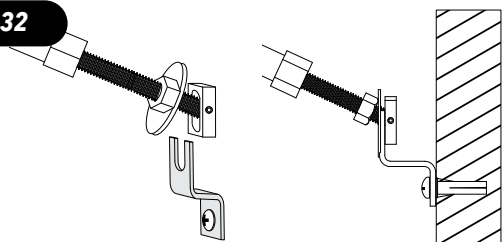

Step 33

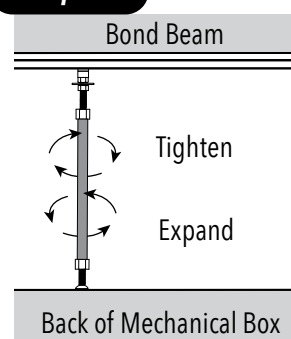

TECHNICAL SUPPORT

If you have any questions about these installation procedures, please contact Technical Support (800) 878-5789 Monday through Friday, 8 am - 5 pm EST.

Automatic Pool Covers, Inc.

(800) 878-5789 • automaticpoolcovers.com

Polymer Box Bracket for Fiberglass Pool

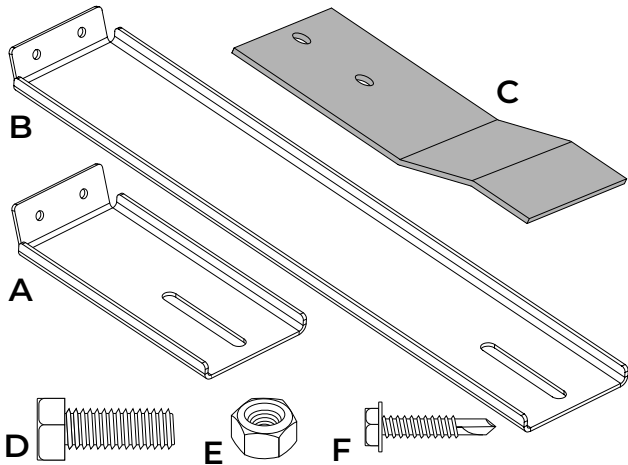

Tools Required

1. 11/64" Drill Bit
2. Chalk line reel
3. Tape Measure
4. 5/16", 9/16" Sockets
5. Cordless Drill

Item Part# Description

Item Part#	Description
A	MC 1052 Bracket attached to Fiberglass Pool - Standard (KA 0494)
B	MC 1069 Bracket attached to Fiberglass Pool - Long (KA 0495)
C	MC 1053 Bracket attached to Polymer Box
D	HC 0063 3/8 - 16 x 1" 18/8 SS
E	HC 0061 Hex Nut 3/8-16 18-8 S/S
F	HC 0149 Hex Head Self Tap Stainless Screw #12 x 1"

BRACKET CHOICE

The distance from the inside of the Box Rail **a** on the Polymer Box to the inside wall **b** of the pool shell will determine which Bracket (MC1052 or MC1069) will be used.

- 9" - 14" use MC1052
- 24" - 28" use MC1069

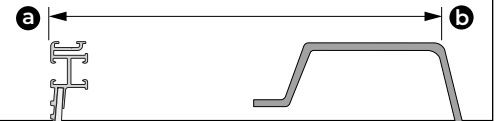

IMPORTANT! BEFORE installing brackets, Polymer Box **MUST** sit level on backfill.

NOTE: Standard Bracket - MC1052 (KA 0494) is shown in illustrations. Long Bracket - MC1069 KA 0495) is installed the same way.

1. Be sure back fill is built up to 15" below the top of the pool so the Polymer Box will rest on top of the back fill and level with pool deck.

2. Along the end of the pool where the Polymer Box and cover will be installed, measure 3/8" down from the top of the pool, then snap a chalk line across the back lip.

3. To determine where the Brackets - MC1052 (Standard - KA 0494) or MC1069 (Long - KA 0495) - will be installed, lay the pieces of the Polymer Box in place. On the side where the motor mechanism will be housed, place the full sized section that includes an installed end, 3' past the edge of the pool. Fit the straight end of the next full section into the flared end.

4. A Bracket will be located at each point where the Polymer Boxes connect/overlap, except for the Motor End which will be placed on pool shell edge. Arrows in Illustrations show proper locations

Secure Bracket to shell with two 1" self tap screws (HC0149).

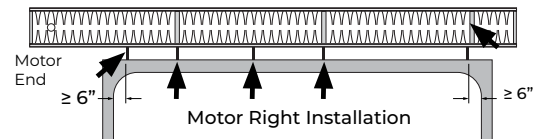
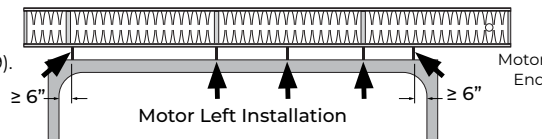

5. MC1053 Bracket orientation depends on the type of lid installation.

6. Orient Bracket as noted in Step 5 and slide the MC1053 Bracket onto the MC1052 (Standard - KA 0494) or MC1069 (Long - KA 0495) Bracket.

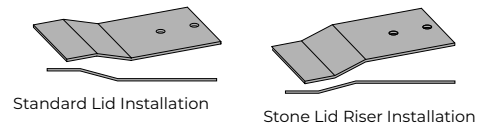

7. Adjust Brackets the appropriate distance and secure nut with bolt with 9/16" wrenches/sockets.

8. After all Brackets are installed, locate the Motor End section of Polymer Box. Beginning on the non-motor end, measure 3' past the end of the pool, and slide the Box Rail on the Polymer Box onto the Bracket.

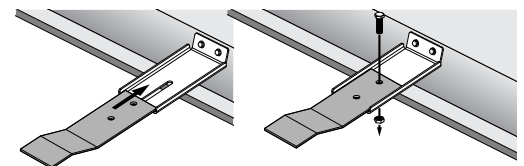

9. Locate a middle section of Polymer Box (without ends). Position section next to end section and onto the Bracket. Secure pieces together following the Polymer Box Installation sheet (DO 0387).

10. When the Polymer Box is in place and assembled, use a cordless drill with 11/64" drill bit and pre-drill 2 holes through the Box Rail, along the grooved indicator mark, and into the Bracket at each Bracket location. **Note:** Drill at an angle so the middle upright on the Box Rail is not hit.

11. Use a cordless drill with 5/16" socket, secure Bracket with two 1" self tap screws (HC0149).

12. Install the remaining sections of Polymer Box onto the Brackets, and secure.

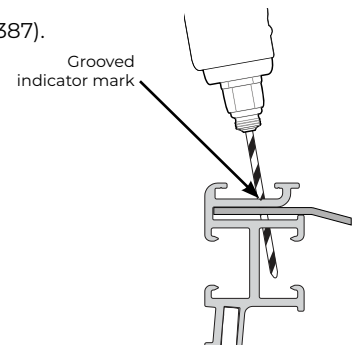

FIBERGLASS POOL BRACKET

KA 0494 / KA 0495 Instructions

IMPORTANT NOTE!

Polymer Box **MUST** sit level on backfill **BEFORE** installing brackets.

PARTS IDENTIFICATION

Item	Part#	Description
A	MC 1052	Bracket attached to Fiberglass Pool - Standard (KA 0494)
B	MC 1069	Bracket attached to Fiberglass Pool - Long (KA 0495)
C	MC 1053	Bracket attached to Polymer Box
D	HC 0063	3/8 - 16 x 1" 18/8 SS
E	HC 0061	Hex Nut 3/8-16 18-8 S/S
F	HC 0149	Hex Head Self Tap Stainless Screw #12 x 1"

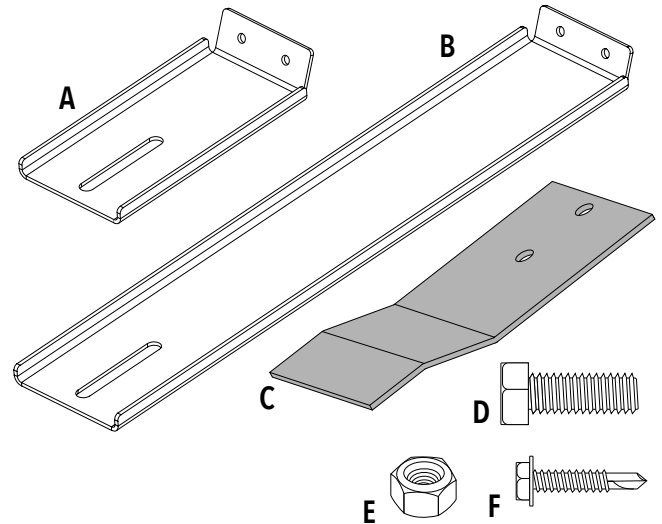

TOOLS REQUIRED

1. 11/64" Drill Bit
2. Chalk line reel
3. Tape Measure
4. 5/16", 9/16" Sockets
5. Cordless Drill

BRACKET CHOICE

The distance from the inside of the Box Rail **a** on the Polymer Box to the inside wall **b** of the pool shell will determine which Bracket (MC1052 or MC1069) will be used.

- 9" - 14" use MC1052
- 24" - 28" use MC1069

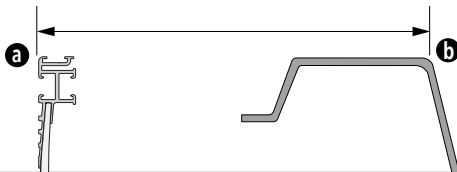

INSTRUCTIONS

NOTE: Standard Bracket - MC1052 (KA 0494) is shown in illustrations. Long Bracket - MC1069 (KA 0495) is installed the same way.

Step 1 Be sure backfill is built up to 15" below the top of the pool so the Polymer Box will rest on top of the backfill and level with pool deck.

Step 2 Along the end of the pool where the Polymer Box and cover will be installed, measure 3/8" down from the top of the pool, then snap a chalk line across the back lip.

Step 3 To determine where the Brackets - MC1052 (Standard - KA 0494) or MC1069 (Long - KA 0495) - will be installed, lay the pieces of the Polymer Box in place. On the side where the motor mechanism will be housed, place the full sized section that includes an installed end, 3' past the edge of the pool. Fit the straight end of the next full section into the flared end.

Step 4 A Bracket will be located at each point where the Polymer Boxes connect/overlap, except for the Motor End which will be placed on pool shell edge. Arrows in Illustrations show proper locations

Step 5 At those locations shown in Step 4, place a Bracket on the chalk line on the pool shell. Use a cordless drill with 5/16" socket, secure Bracket to the pool shell with two 1" self tap screws (HC0149).

Step 2

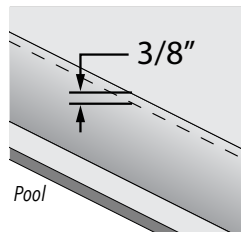

Step 3

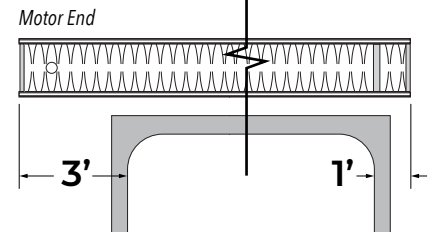

Step 4

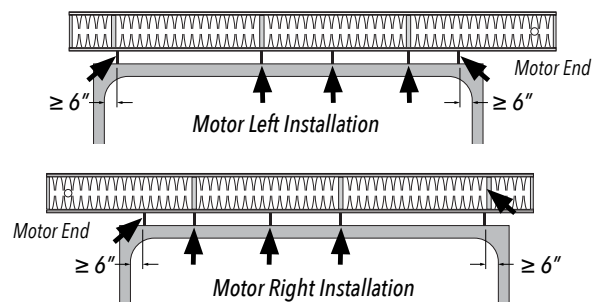

Step 5

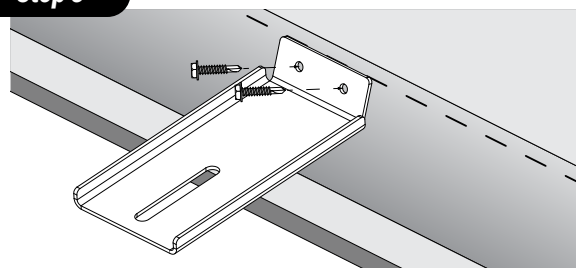

INSTRUCTIONS

Step 6 MC1053 Bracket orientation depends on the type of lid installation. For Standard Lid, orient the Bracket as shown in Illustration 6.1. For Stone Lid Riser, orient the Bracket as shown in Illustration 6.2.

Step 7 Orient Bracket as noted in Step 6 and slide the MC1053 Bracket onto the MC1052 (Standard - KA 0494) or MC1069 (Long - KA 0495) Bracket.

Step 8 Loosely attach MC1053 to MC1052 (Standard - KA 0494) or MC1069 (Long - KA 0495) using HC0063 bolt, HC0061 nut. Note: using the 1st hole will provide 2" more reach.

Step 9 Adjust Brackets the appropriate distance and secure nut to bolt with 9/16" wrenches/sockets.

Step 10 After all Brackets are installed, locate the Motor End section of Polymer Box. Beginning on the non-motor end, measure 3' past the end of the pool, and slide the Box Rail on the Polymer Box onto the Bracket.

Step 11 Locate a middle section of Polymer Box (without ends). Position section next to end section and onto the Bracket. Secure pieces together following the Polymer Box Installation sheet (DO 0387).

Step 12 When the Polymer Box is in place and assembled, use a cordless drill with 11/64" drill bit and pre-drill 2 holes through the Box Rail, along the grooved indicator mark, and into the Bracket at each Bracket location. Note: Drill at an angle so the middle upright on the Box Rail is not hit.

Step 13 Use a cordless drill with 5/16" socket, secure Bracket with two 1" self tap screws (HC0149).

Step 14 Install the remaining sections of Polymer Box onto the Brackets, and secure them as in Step 12 & 13.

Fiberglass Pool Bracket installation is complete.

Step 6.1

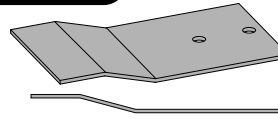

Standard Lid Installation

Step 6.2

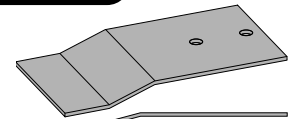

Stone Lid Riser Installation

Step 7

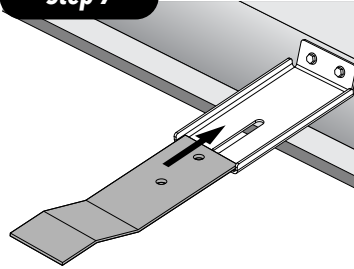

Step 8

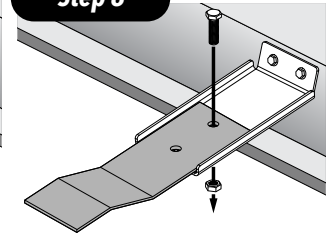

Step 10

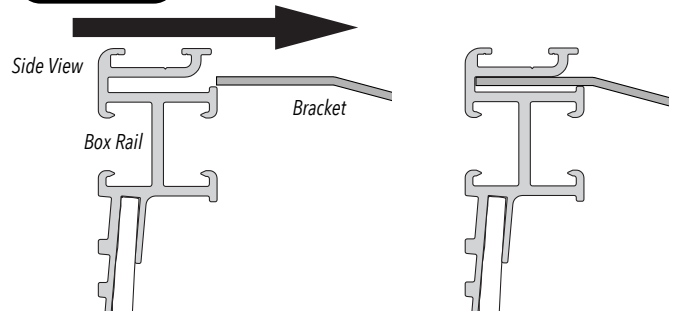

Step 12

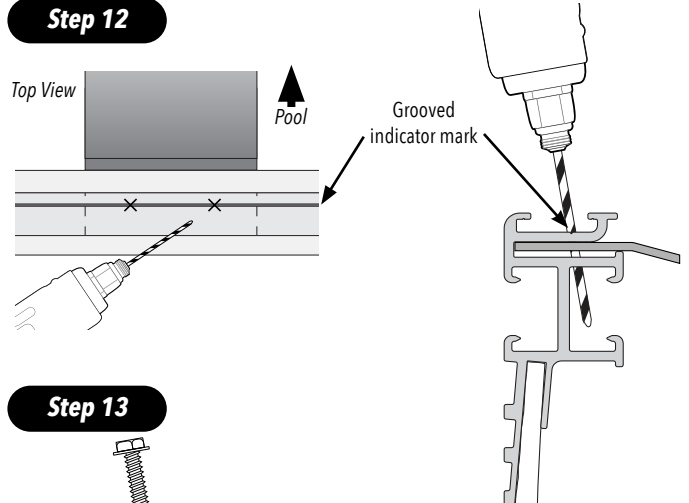

Step 13

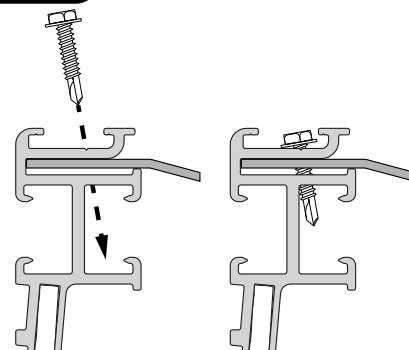

TECHNICAL SUPPORT

If you have any questions about these installation procedures, please contact Technical Support (800) 878-5789.

Automatic Pool Covers, Inc.

(800) 878-5789 • automaticpoolcovers.com

RECESSED WOOD BOX

Under Track Construction Instructions

REQUIRED MATERIALS

NOTE: These instructions are based on a 13" sized box. Adjust accordingly for larger box sizes.

Treated Wood:
 2" x 12" x 12'
 2" x 2" x 8'
 2" x 4" x 10'

Stud Pine:
 2" x 4" x 8'

Hardware:
 Box of 16 D spiral galvanized nail

Tools:
 Hammer
 Framing Square
 Tape Measure

String Line
 Level
 Drill
 1/2" Drill Bit
 Nail Set

PREPARATION

EXCAVATION:

Prior to setting a wood recessed box, make sure that the area where the box will be sitting is 16" below the deck height.

CALCULATING BOX LENGTH:

Take the track space (the inside measurement between the tracks plus 1"), then add 4'. Example: (Space Between Tracks + 1") + 4' = Box Length

BOX SIZE REQUIREMENTS:

Track Length:	1' - 44'	45' - 55'	56' - 65'	66' +
Box Size:	13"	14"	15"	16"

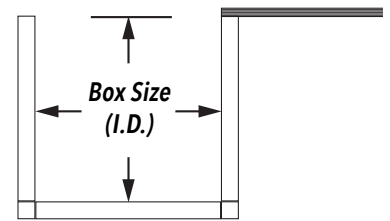

- Standard mechanism ID is 10-1/4" to 14-1/4"
- Standard aluminum lid and hinge is 16-3/4" wide. A wide lid, 19", is available.
- Wider mechanism brackets will be needed for boxes wider than 14".
- APC's hybrid webbing will roll up larger than standard white Dacron webbing.

INSTRUCTIONS

NOTE: These instructions are based on a 13" I.D. sized box. Adjust accordingly for larger box sizes.

- Step 1** Locate two 2" x 12" x 12' treated boards and cut 16" off of each board to be used as End Boards.
- Step 2** Nail a 2" x 2" x 8' treated board to the bottom of both 2" x 12" using 16D spiral galvanized nails.
- Step 3** Lay the two uncut 2" x 12" x 12' side by side 16" apart (O.D.) Use a large framing square to square up the ends of 2 of the 2" x 12" x 12'.
- Step 4** Nail one of the 16" End Boards to the end of the 2" x 12" x 12'. With the tip of this 16" piece flush to the top of the 2" x 12" (not flush with the top of the 2 x 2), use 8 nails to secure each End Board. Turn box over and check to make sure box is square.
- Step 5** Cut the 2" x 4" x 10' treated board into 16" pieces called Base Boards.
- Step 6** Take three Base Boards, space them equally apart and nail them to the top of the 2" x 2"s. Be sure the outside of the 16" piece is flush with the outside of the box. Turn the box over.
- Step 7** Using a 1/2" bit, drill 2" holes down into the remaining uncut 2" x 4" x 12's, the 3' and the 12" approximately 2' apart. Make sure not to drill within 3" of the end of the boards.
- Step 8** Position a drilled 2" x 4" x 12' flush on the top of the backside of the box and trim any remaining materials. Hammer nails into drilled holes, and use a nail punch to drive nails all the way into the 2" x 12".

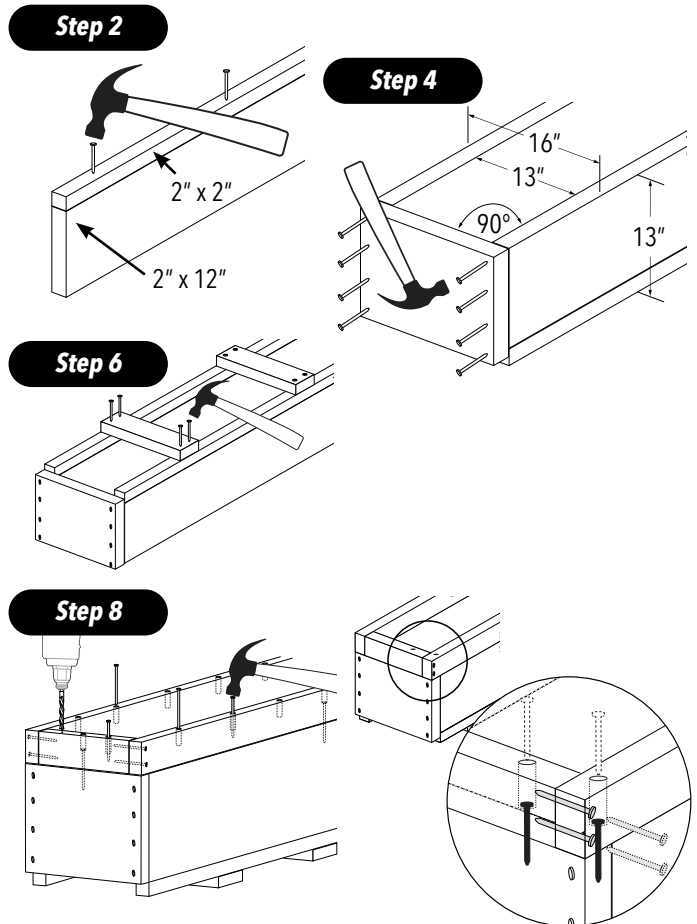

INSTRUCTIONS

- Step 9** Repeat Step 8 on other three sides of box.
- Step 10** Cut one of the 2" x 4" x 8' pine boards into 13" pieces called Spacers.
- Step 11** Set the Spacers equally apart, flush to the inside top of the box. Toenail them in place to be removed after the concrete has been poured.
- Step 12** Measure the 2 remaining 2" x 12" and cut to the appropriate size of the box. Repeat previous steps to build other half of box.
- Step 13** Position the 2 box halves close to where the box will be installed.
- NOTE:** To prevent the box from being installed upside down, make sure spacers are at the top.
- Step 14** Lay the two box halves end to end. Use a string line to line up back of box. Make sure the box is level and straight.
- Step 15** Cut the remaining 2" x 4" untreated boards into two 2' pieces to use as Splices to join the two box halves together.
- Step 16** Nail one of the 2' Splices into one half of the box 5" below the top outside of the box. Make sure the box butts together and then nail the other half of the splice into the other half of the box. Install remaining 2' piece to the other side of box.
- CAUTION:** When using 16D nails, be sure to nail them in at an angle so the sharp end of the nail is not exposed on the inside of the box. Exposed nails may tear the vinyl cover.
- Step 17** Once the box is completely constructed, move it to the end of the pool. Make sure the motor side of the box is 36" outside of intended track dimension. Square the box up to pool by making diagonal measurements. Make sure the diagonal is within 2" inches or less.
- Step 18** Cut the remaining 2" x 4" boards into six 4' Stakes. Drive the Stakes into the ground around the outside of the box.
- Step 19** Level box to the finished deck height. Nail the Stakes to the outside of the box making sure they are lower than the top of the box. Nails should not enter the inside of box.
- Step 20** When box is level, backfill around box.
- Step 21** To help anchor the box into the concrete, drive 16D nails about half-way in, on the outside of the box about two inches 2" down from the top. Angle the nails in a crisscross (X) pattern around the box every 18".

Step 11

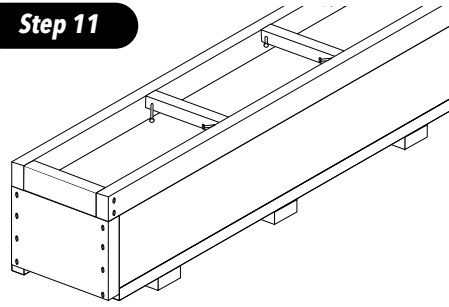

Step 16

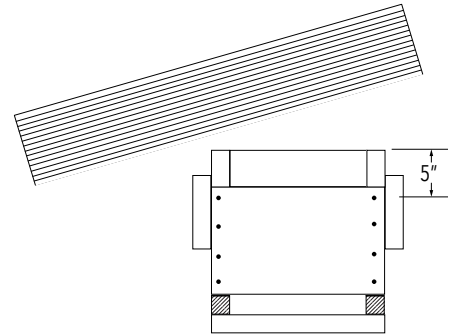

Step 17

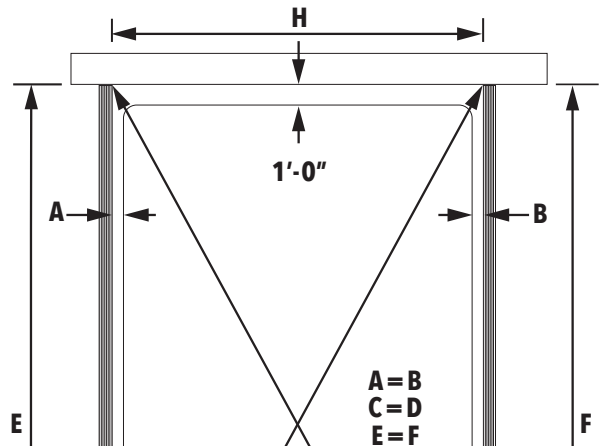

Step 21

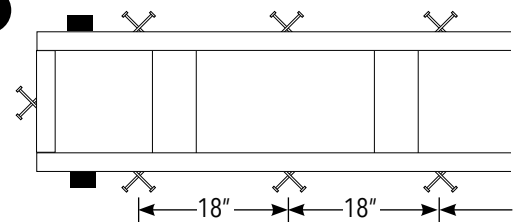

TECHNICAL SUPPORT

If you have any questions about these installation procedures, please contact Technical Support (800) 878-5789 Monday through Friday.

Automatic Pool Covers, Inc.

(800) 878-5789 • automaticpoolcovers.com

RECESSED WOOD BOX
Top Track Construction Instructions

REQUIRED MATERIALS

NOTE: These instructions are based on a 13" sized box. Adjust accordingly for larger box sizes.

Treated Wood:

- 2" x 12" x 12'
- 2" x 2" x 8'
- 5-1/4" x 10' Deck Board

Stud Pine:

- 2" x 4" x 8'

Hardware:

- Box of 16 D spiral galvanized nail

Tools:

- Hammer
- Square
- Tape Measure
- String Line
- Level

PREPARATION

EXCAVATION:

Prior to setting a wood recessed box, make sure that the area where the box will be sitting is 16" below the deck height.

CALCULATING BOX LENGTH:

Take the track space (the inside measurement between the tracks plus 1"), then add 4'. Example: (Space Between Tracks + 1") + 4' = Box Length

BOX SIZE REQUIREMENTS:

Track Length:	1' - 44'	45' - 55'	56' - 65'	66' +
Box Size:	13"	14"	15"	16"

- Standard mechanism I.D. is 10-1/4" to 14-1/4"
- Standard aluminum lid and hinge is 16-3/4" wide. A wide lid, 19", is available.
- Wider mechanism brackets will be needed for boxes wider than 14".
- APC's hybrid webbing will roll up larger than standard white Dacron webbing.

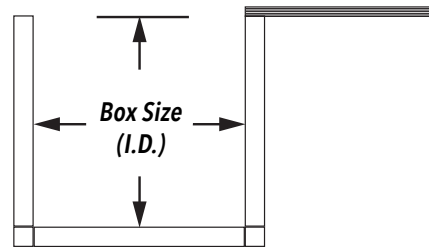

INSTRUCTIONS

NOTE: These instructions are based on a 13" I.D. sized box. Adjust accordingly for larger box sizes.

- Step 1** Locate two 2" x 12" x 12' treated boards and cut 16" off of each boards to be used as End Boards.
- Step 2** Nail a 2" x 2" x 8' treated board to the bottom of both 2" x 12" using 16D spiral galvanized nails.
- Step 3** Lay the two uncut 2" x 12" x 12' side by side 16" apart (O.D.) Use a large framing square to square up the ends of 2 of the 2" x 12" x 12'.
- Step 4** Nail one of the 16" End Boards to the end of the 2" x 12" x 12'. With the tip of this 16" piece flush to the top of the 2" x 12" (not flush with the top of the 2 x 2), use 8 nails to secure each End Board. Turn the box over and check to make sure box is square.
- Step 5** Cut the 5-1/4" x 10' treated board into 16" pieces called Base Boards.
- Step 6** Take three Base Boards, space them equally apart and nail them to the top of the 2" x 2"s. Be sure the outside of the 16" piece is flush with the outside of the box.
- Step 7** Turn the box over. Cut one of the 2" x 4" x 8' pine boards into 13" pieces called Spacers.

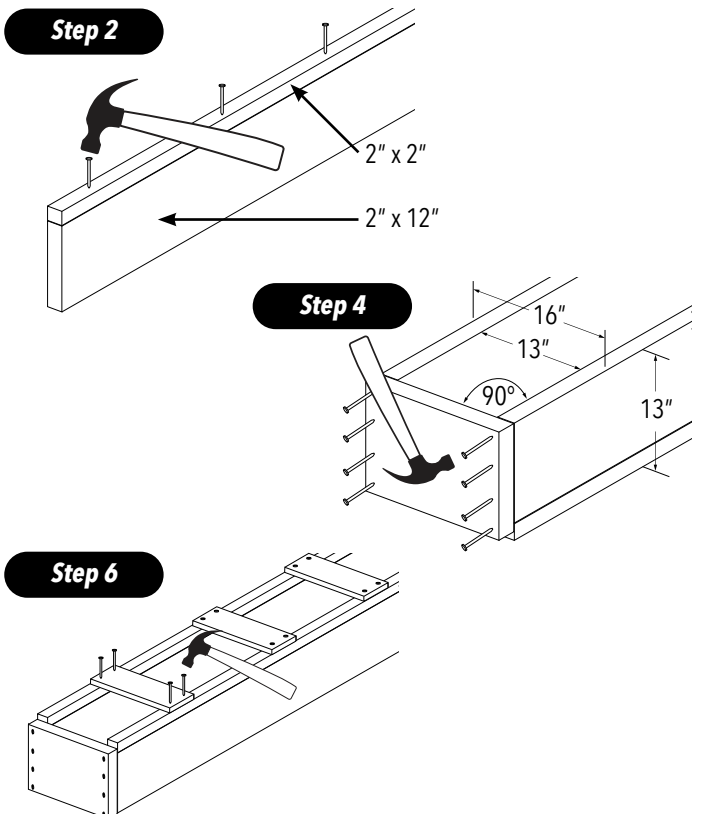

INSTRUCTIONS

Step 8 Set the Spacers equally apart, flush to the inside top of the box. Toenail them in place to be removed after the concrete has been poured.

Step 9 Measure the 2 remaining 2" x 12" and cut to the appropriate size of the box. Repeat previous steps to build other half of box.

Step 10 Position the 2 box halves close to where the box will be installed.

NOTE: To prevent the box from being installed upside down, make sure spacers are at the top.

Step 11 Lay the two box halves end to end. Use a string line to line up back of box. Make sure the box is level and straight.

Step 12 Cut the remaining 2" x 4" pine stud into two 2' pieces to use as Splices to join the two box halves together.

Step 13 Nail one of the 2' Splices into one half of the box 5" below the top outside of the box. Make sure the box butts together and then nail the other half of the splice into the other half of the box. Install remaining 2' piece to the other side of box.

CAUTION: When using 16D nails, be sure to nail them in at an angle so the sharp end of the nail is not exposed on the inside of the box. Exposed nails may tear the vinyl cover.

Step 14 Once the box is completely constructed, move it to the end of the pool. Box should be at least 1' from the end of the pool. Make sure the motor side of the box is 36" outside of intended track dimension. Square the box up to pool by making diagonal measurements. Make sure the diagonal is within 2" inches or less.

Step 15 Cut the remaining 2" x 4" boards into six 4' Stakes. Drive the Stakes into the ground around the outside of the box.

Step 16 Level box to the finished deck height. Nail the Stakes to the outside of the box making sure they are 6" lower than the top of the box. Nails should not enter the inside of box.

Step 17 When box is level, backfill around box.

Step 18 To help anchor the box into the concrete, drive 16D nails about half-way in, on the outside of the box about two inches 2" down from the top. Angle the nails in a crisscross (X) pattern around the box every 18".

Step 8

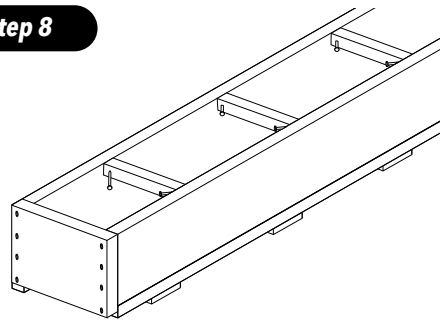

Step 13

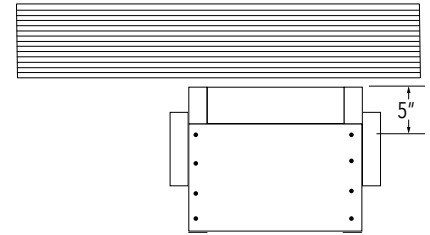

Step 14

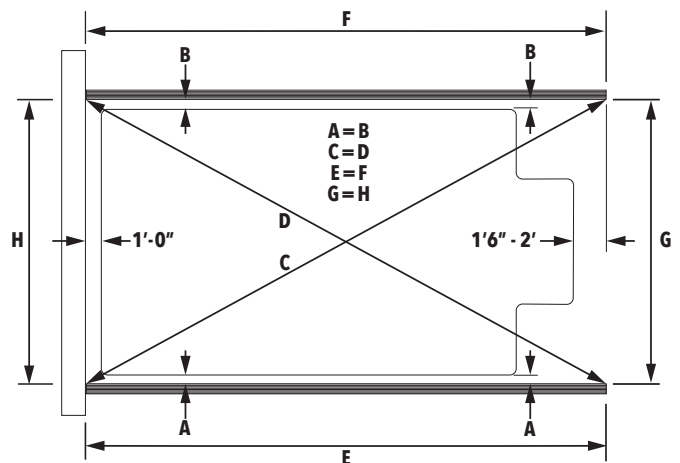

Step 18

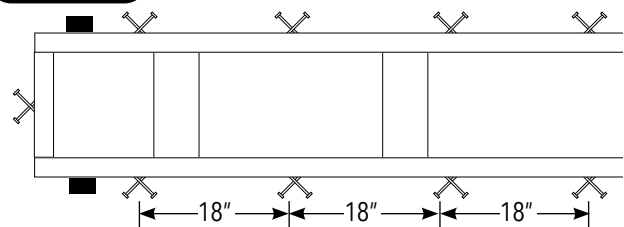

TECHNICAL SUPPORT

If you have any questions about these installation procedures, please contact
Technical Support (800) 878-5789 Monday through Friday.

Automatic Pool Covers, Inc.

(800) 878-5789 • automaticpoolcovers.com

CONCRETE HOUSING Construction Instructions

Standard dig for pools up to 24' x 45' (Contact APC if pool is wider or longer.)

- It is crucial for all lengths, widths and diagonals to be equal and square.
- Mechanism box placement is typically along the narrow end of the pool. (Call APC if box will go on long side).
- Dig Mechanism Box area 20" deep from the top of the form.
- Dig Mechanism Box area 38" wide from pool form to pool form (inside dimension) for the Mechanism Box with 12" thick walls.
- Mechanism Box should be 32" wide if back wall of the box will be only 6" thick (minimum).
- Dig one side of the Mechanism Box with a 36" offset from corner of pool form to form for end Mechanism Box (Do not put 36" offset on side of pool with raised wall that will pass over box).
- Dig other side of Mechanism Box with a 12" offset from corner of pool form to form for end of Mechanism Box.

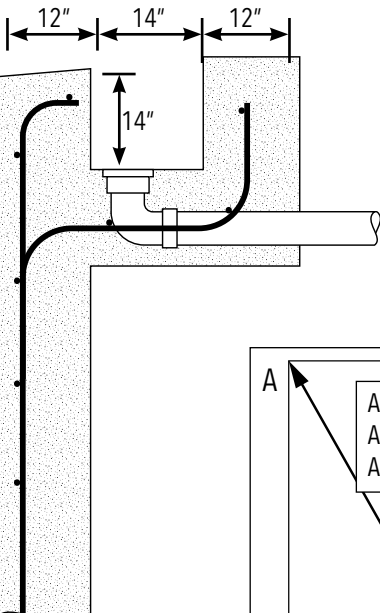
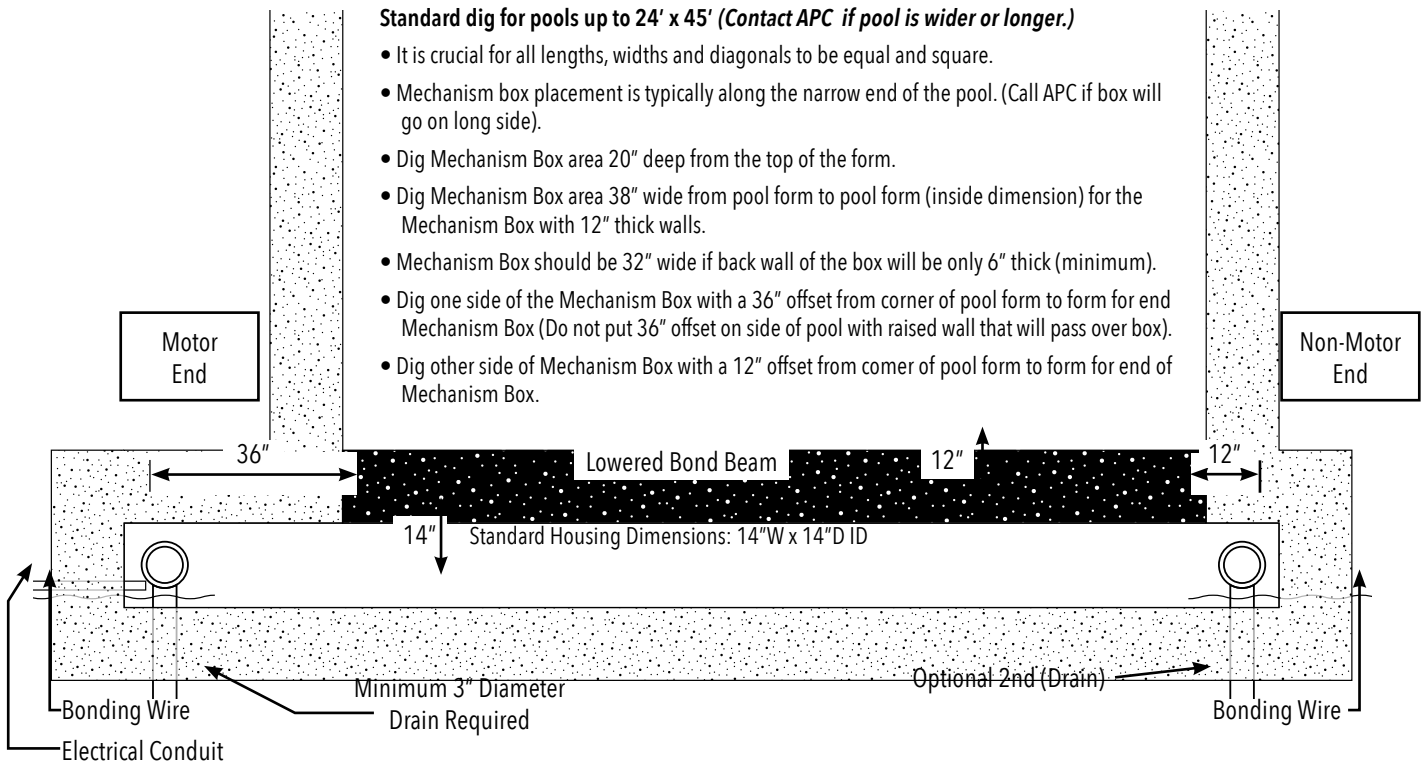

		POOL WIDTH		
		Up To 20'	25'	30'
POOL LENGTH	40'	14"	14"	16"
	55'	14"	14"	16"
	65'	15"	15"	16"
	80'	16"	16"	18"

Minimum Housing Width and Depth

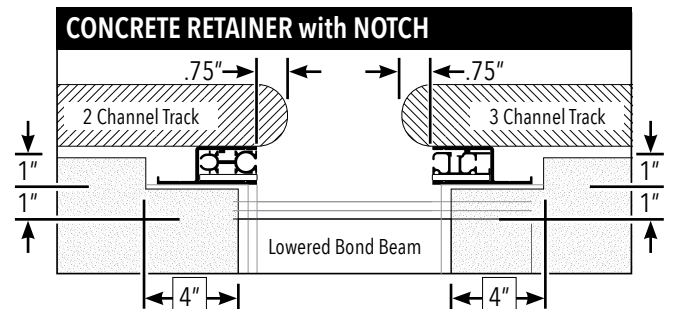
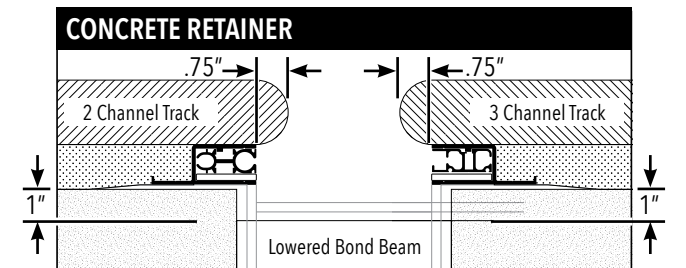
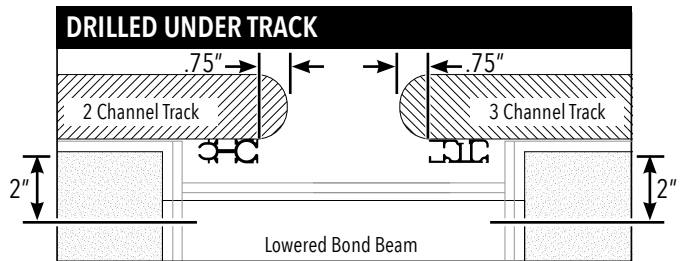
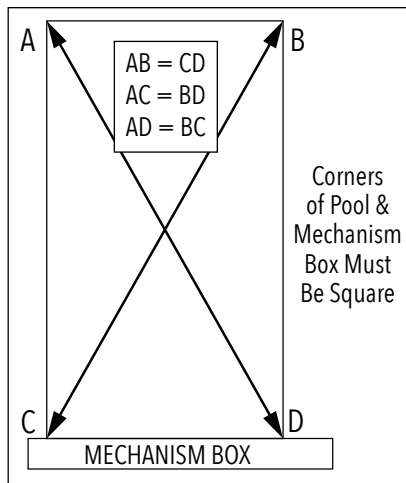

CONCRETE HOUSING FORM

MATERIALS

ID	Qty	Description
A	2	2x12 Framing that is inside pool width plus 4'
B	4	2x4 Framing typically half the 2x12 length
C	2	2x4 Framing cut to 11" blocks
D	?	2x12 Framing cut in 11" long blocks (ends and every 36")
E		1/2" Plywood Ripped to 13-1/2" 3" Framing Nails 2" Roofing Nails

INSTRUCTIONS

- Step 1** Cut 2x4's: two (2) at 11" **C**, four (4): half the 2x12 length (typically) **B**.
- Step 2** Cut 2x12's: 11's for both ends and every 36" **D**; two (2) equal to the inside pool width plus 4' **A**.
- Step 3** Rip the 1/2" plywood **E** to 13-1/2" wide. Pieces will be cut to the length of the box.
- Step 4** Nail the 2x4 and 2x12 end blocks 3-1/2' below main board and 1/4" proud.
- Step 5** Nail a 2x12 block centered on the joint location of the long 2x4's. Nail long 2x4's to the end blocks and joint block.
- Step 6** Nail blocks the length of the form every 36".
- Step 7** Check and make sure form straight and square. To help keep form rigid, use roofing nails to attach plywood.

Step 4

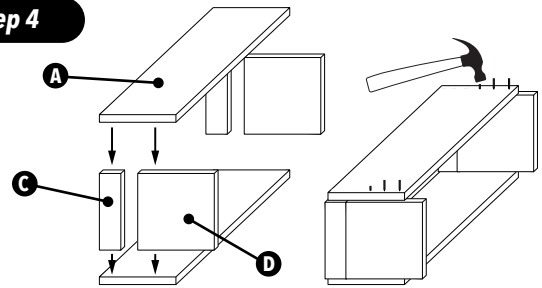

Step 5

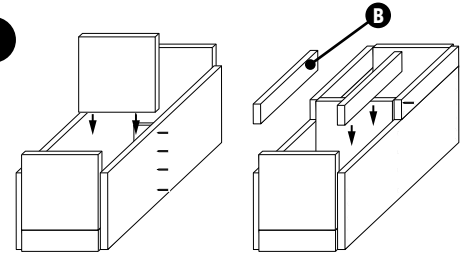

Step 6

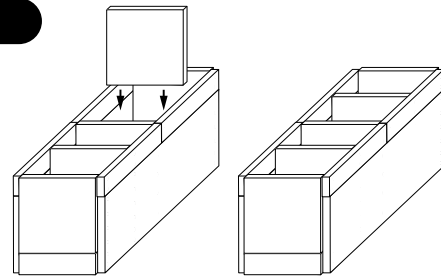

Step 7

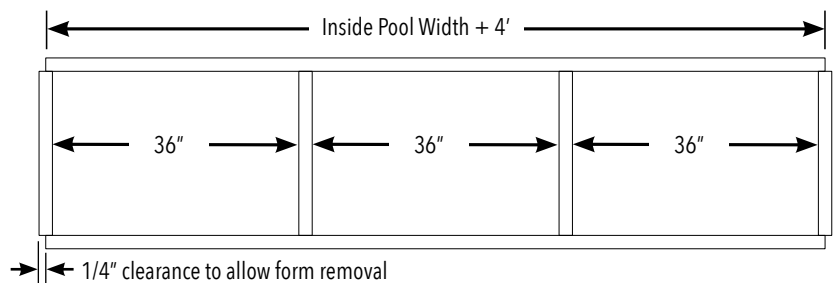
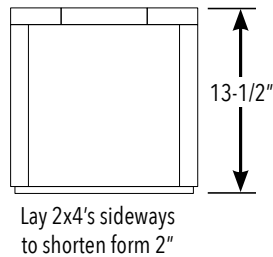
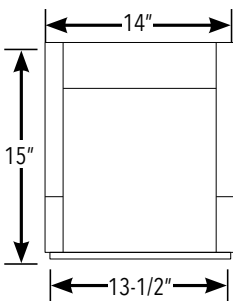
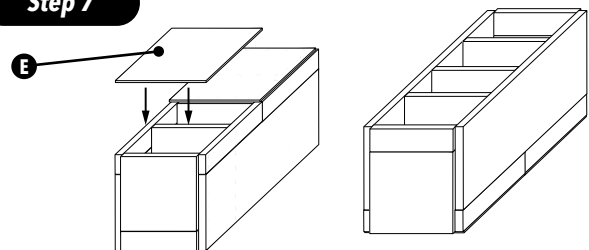

TECHNICAL SUPPORT

If you have any questions about these installation procedures, please contact Technical Support (800) 878-5789 Monday through Friday, 8 am - 5 pm EST.

Automatic Pool Covers, Inc.

HIDDEN LEAD EDGE
Gunite Encapsulation Specifications

SPECIFICATIONS

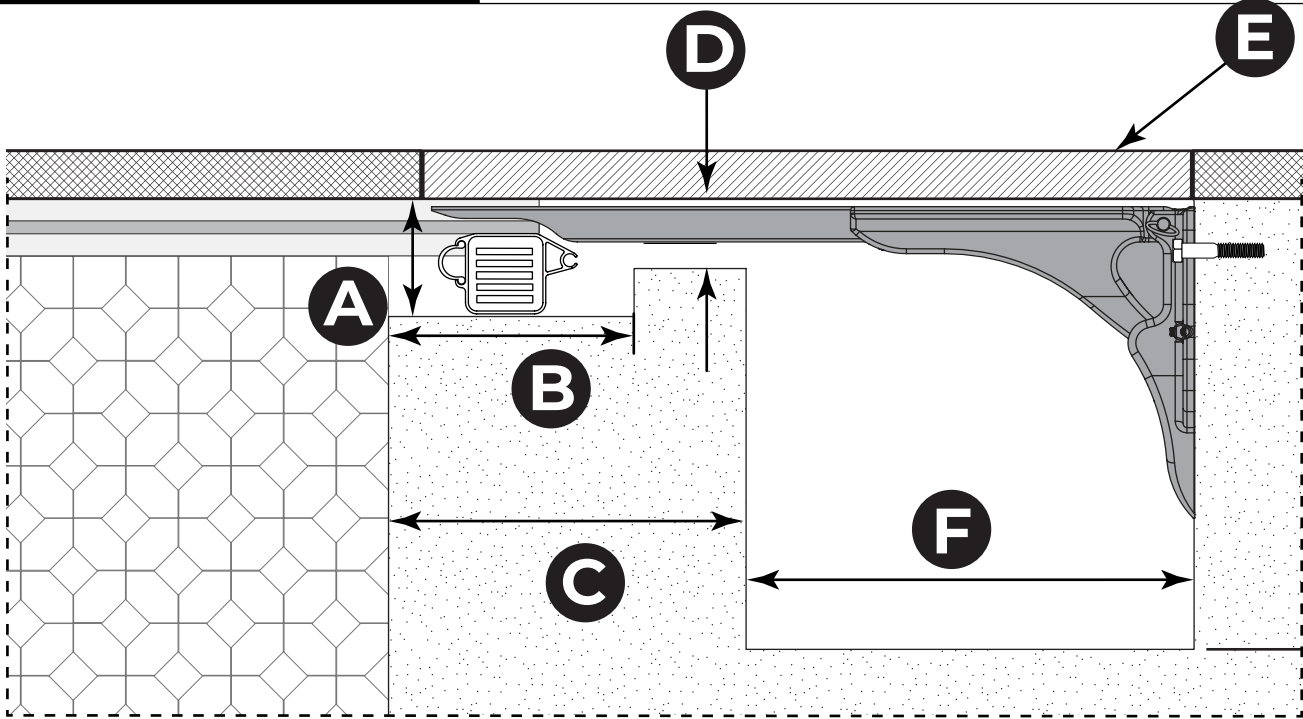

A	Lead Edge Clearance.....	3.5"
B	Lead Edge Depth Clearance.....	6.0"
C	Bond Beam.....	12.0"
D	Cover Clearance.....	1.0"
E	Lid Stones.....	24" x 24"
F	Box Width.....	13.0"

Note: To provide the necessary clearance, simply orientate the Lead Edge the opposite way as is typically oriented.

Note: Skimmer to be dropped 2".

Note: All measurements with tile.

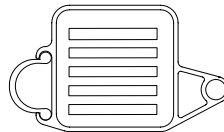

Typical Orientation

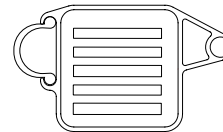

Hidden Lead Edge Orientation

TECHNICAL SUPPORT

If you have any questions about these installation procedures, please contact Technical Support (800) 878-5789 Monday through Friday.

POWERTOCH WIRING

Electrical Wiring Diagram

WARNING



Do not attempt to connect, or disconnect, the control unit or motor harness while supply power is ON. Doing so can irreversibly damage controller and cover motor, and potentially cause serious injury or death.

SYSTEM LAYOUT

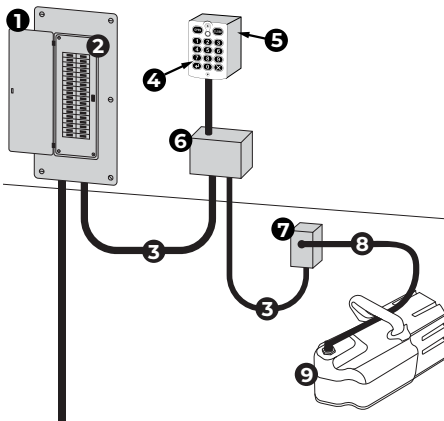

1. Main circuit breaker panel
2. Dedicated 120VAC/20 amp GFCI-equipped circuit breaker - must be equipped with ground fault sensing provisions. Do not share the circuit breaker with any AC loads.
3. High Voltage Conduit - holds 3 12 AWG wires for 120VAC @ 20 amps
4. PowerTouch Control Pad - electronic module communicates with motor
- IMPORTANT: The touch pad must be located in full view of pool, at least 5' above grade.**
5. High Voltage Junction Box - outdoor rated PVC box supports the transition from underground conduit to 3-conductor harness
6. High Voltage Junction Box - outdoor rated box provides shielding to connections from keypad and motor harness. Located in cover housing.
7. Motor Harness - 4-conductor cable supplies high voltage drive to motor
8. 120VAC 3/4HP Motor

WIRING

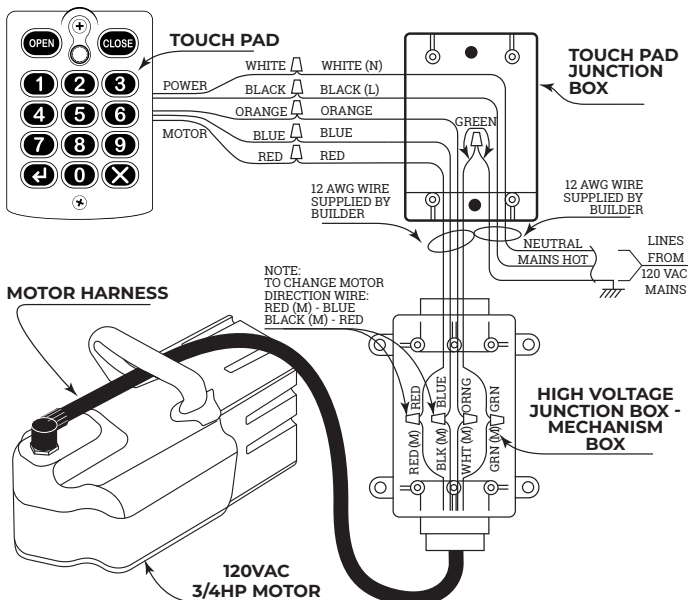

AC Requirements - Pull four (4) 12 gauge wires from the motor side of the recessed housing to the touch pad location. Pull a hot, a neutral and an unbroken green ground from the panel to the touch pad location. The power source must be on a 20 amp dedicated GFCI breaker. Follow all national and local codes regarding wire size, grounding and connectors. **NOTE: Bonding wire should be at both ends of the box.**

Touch Pad Location - A 3/4" conduit needs to be connected from the motor side of the recessed housing to the touch pad location. The 3/4" conduit going into the recessed housing should junction into a standard J-Box.

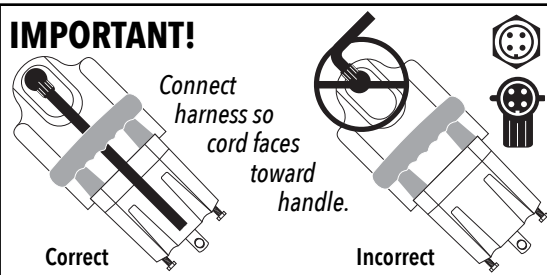

TECHNICAL SUPPORT

If you have any questions about these procedures, please contact Technical Support (800) 878-5789 Monday through Friday, 8 am - 5 pm EST.

PowerTouch Operation

INDICATOR LIGHT MEANINGS

- SOLID GREEN - System: Idle
- SOLID RED - New code can be entered
- FLASHING GREEN - System: In motion
- FLASHING RED - Obstruction or error

CONTROLLER OPERATION

Be sure all electrical connections within their respective junction boxes are secure with appropriate hardware.

1. Enter code **1 2 3 4**
2. Press "Enter" **✓**
3. Press **OPEN** or **CLOSE** to move cover in the desired direction.
4. Press **X** to disable touch pad. It will automatically shut off in 20 seconds.

CHANGING THE CODE

The default code for all new controllers, preset at the factory, is:

1 2 3 4

1. Press and hold **✓** until **RED** light glows.
2. Enter new desired 4 number code.
3. The **RED** light will turn off when the new code has been accepted, and the controller is ready for normal use.

ENTERING SERVICE CODE

The Service Code allows access to the touch pad without modifying or knowing the owner's code.

1. Press and hold **✓** until **RED** light glows.
2. Wait 2 seconds then press and hold **✓** until the **RED** light starts to flash.
3. Input Service Code **9 0 0 1** then may have to push **✓**
4. The **RED** light will turn off and the **GREEN** light will glow.
5. The cover can be opened or closed by pressing the appropriate button on the pad, **OPEN** or **CLOSE**

NOTE: The touch pad will automatically shut off in 10 minutes if the cover is not run or disabled.

CHANGING THE TORQUE LIMIT

The factory torque setting are **OPEN**=2, **CLOSE**=2. Based on the pool cover installation, modifications may be necessary.

1. Press and hold **✓** until **RED** light glows.
2. Press and hold either **OPEN** or **CLOSE** to change torque setting in that direction. Hold button until the **RED** light starts blinking **GREEN**, then release.
3. The **GREEN** light will flash, counting out the current torque setting (1, 2, 3 or 4) for 3 sequences.
4. Increase or decrease the torque setting when the light is blinking by pressing 1, 2, 3 or 4. The minimum setting is 1, the maximum is 4. The **GREEN** light will then count out the modified torque setting.
5. Repeat if necessary to change the torque setting in the opposite direction. Press **X** to save setting when light is blinking or the unit will automatically exit and save setting when the blinking sequence is completed.

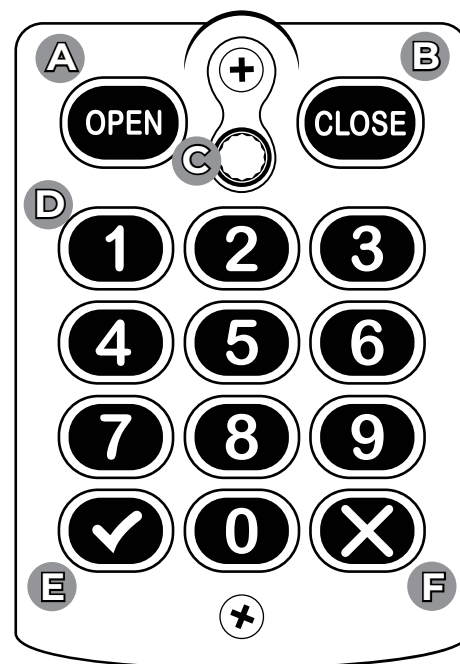

- | | |
|-------------------|---------------|
| A OPEN Cover | B CLOSE Cover |
| C Indicator Light | D Number Keys |
| E Enter | F Cancel/Exit |

KEY SWITCH WIRING

Electrical Wiring Diagram

WIRING INSTRUCTIONS

Wire all low voltage wires from the 8 pin harness to the keyswitch and sensor following the diagram.

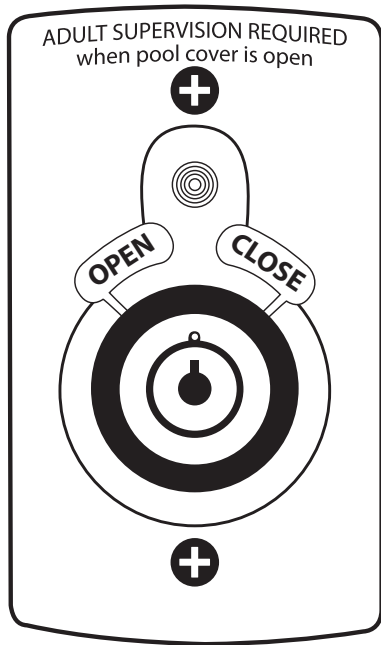
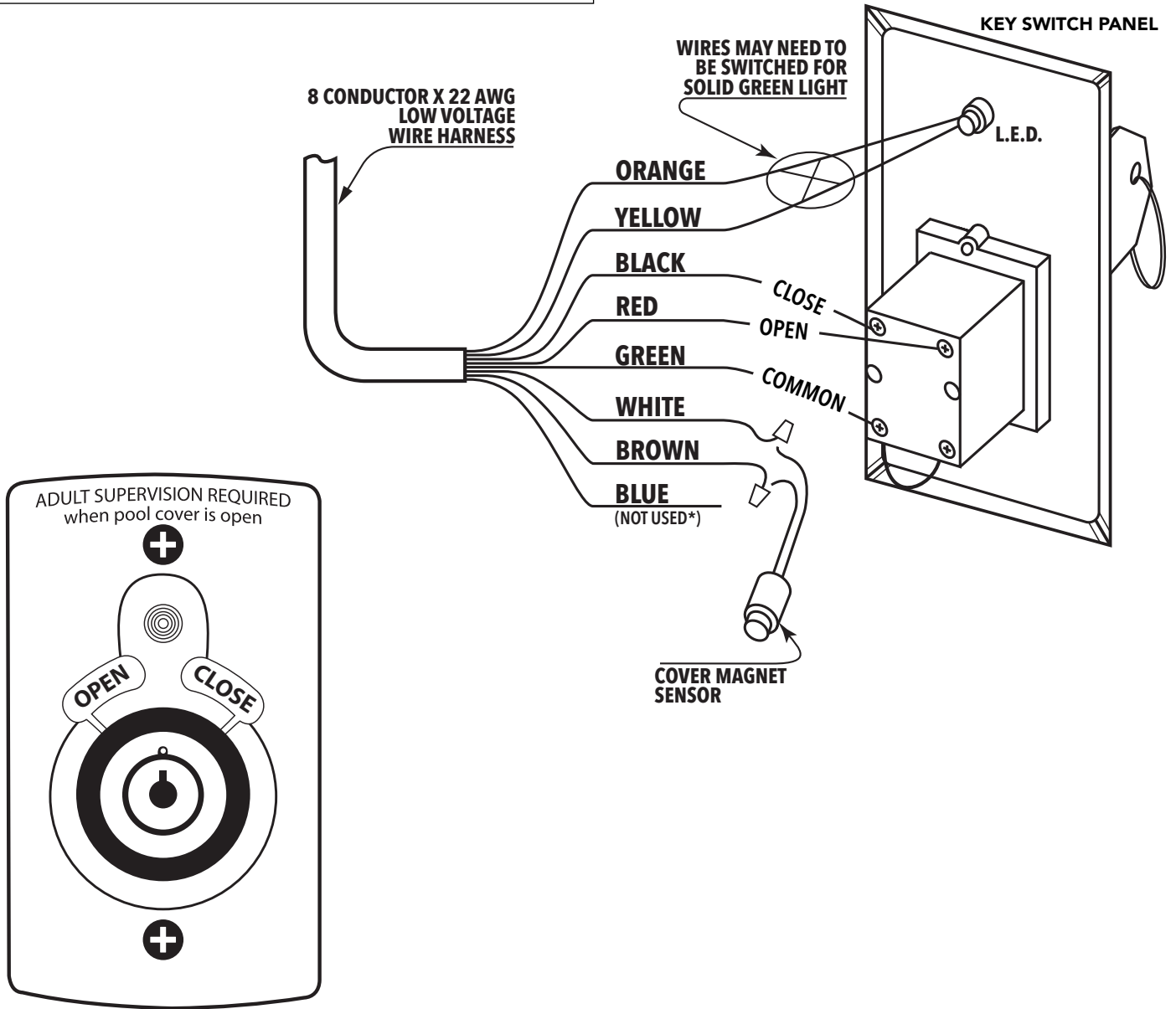

TECHNICAL SUPPORT

If you have any questions about these procedures, please contact Technical Support (800) 878-5789 Monday through Friday, 8 am - 5 pm EST.

WARNING



Do not attempt to connect, or disconnect, the control unit or motor harness while supply power is ON. Doing so can irreversibly damage controller and cover motor, and potentially cause serious injury or death.

SYSTEM DETAILS

Outside of Housing

1. **Key Switch** - device is mounted at pool side and determines the cover movement direction
2. **Low Voltage Conduit** - conduit holds 5-conductor 18 to 22 GA stranded, low voltage cable for signaling
3. **Main circuit breaker panel**
4. **Dedicated 120VAC/20 amp GFCI-equipped circuit breaker** - unshared circuit breaker with ground fault sensing provisions.
5. **High Voltage Conduit** - PVC conduit holds qty=3 12 AWG wires for 120VAC@20 amps

Within Recessed Housing

6. **High Voltage Junction Box** - outdoor rated PVC box supports the transition from underground conduit to 3-conductor harness
7. **Low Voltage Junction Box** - outdoor rated box provides shielding for the low voltage connections to key switch & cover position switch
8. **Sensor Motor Adapter (SMA)** - electronic module communicates with the motor, pool-side key switch, and magnetic cover position sensor
9. **120VAC Harness** - 3-conductor harness is equipped with a waterproof strain relief grommet mounted in the cover of the junction box
10. **Low Voltage Harness** - gray 8-conductor harness communicates to the pool-side key switch and the cover position sensor
11. **Cover Position Sensor** - magnet sensor announces the presence of a flat magnet switch and the cover position sensor
12. **120VAC 3/4HP Motor**
13. **Motor Harness** - 4-conductor cable supplies high voltage drive to the motor

SYSTEM LAYOUT

Outside of Housing

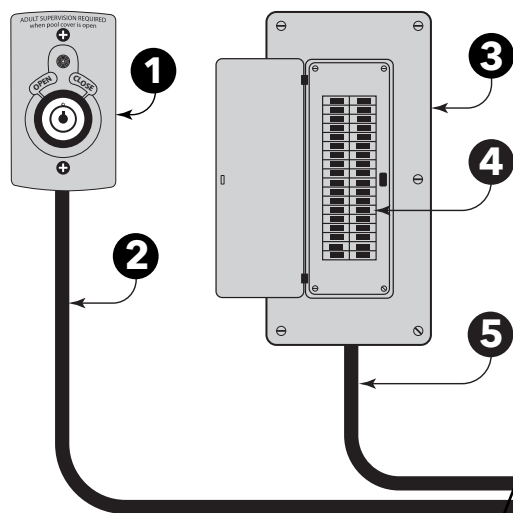

Within Recessed Housing

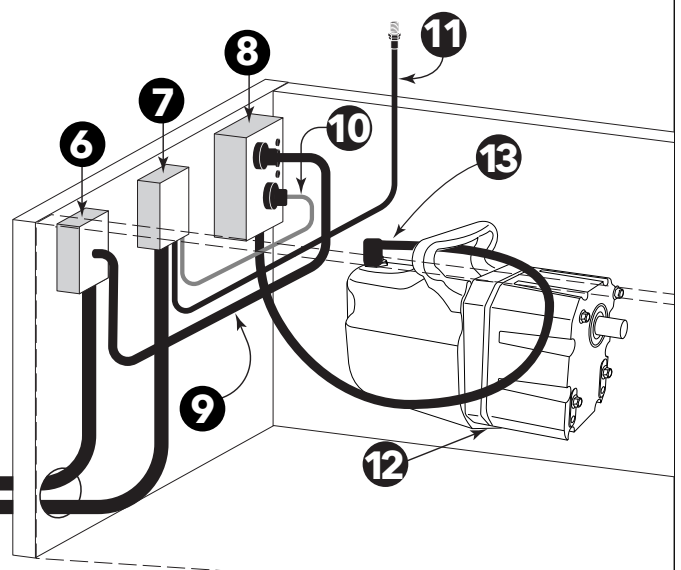

WIRING INSTRUCTIONS

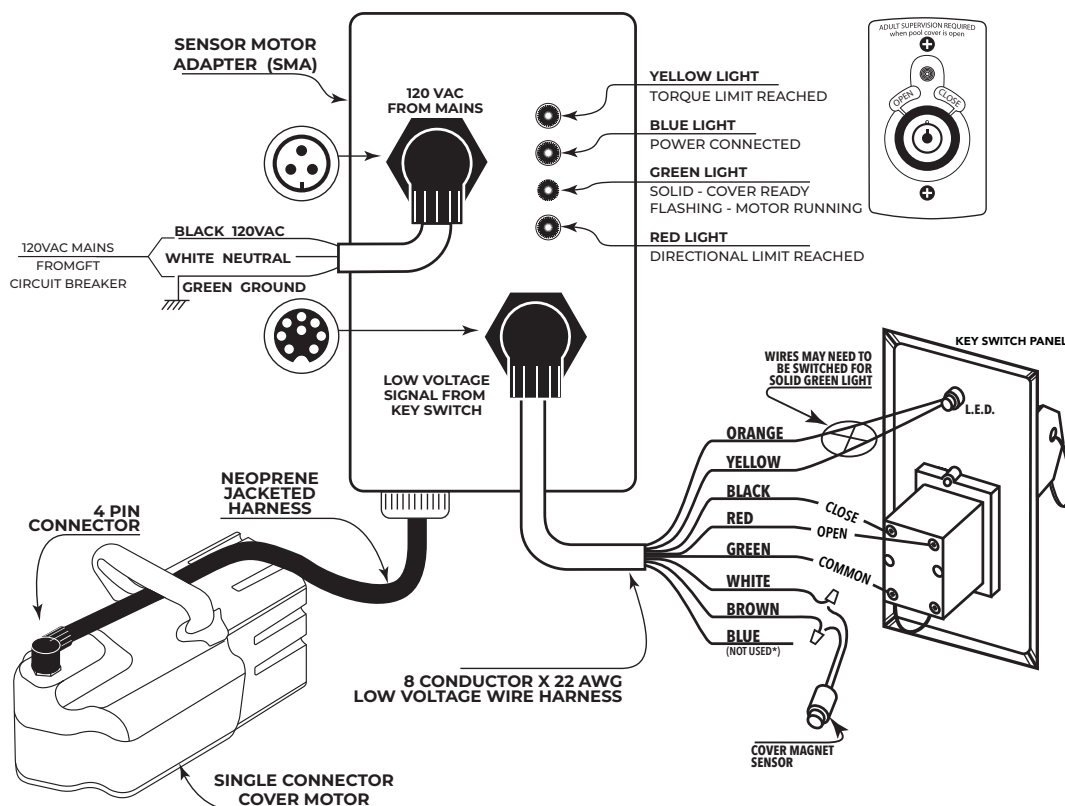

1. Secure SMA at the highest point possible to the front of the housing with supplied hardware.
2. Wire all low voltage wires from the 8 pin harness to the keyswitch and sensor following the above diagram.
3. Secure 8 pin harness to the low voltage terminal on the SMA.
4. Wire all high voltage wires from the 3 pin harness to power source wires following the above diagram.
5. Secure 3 pin harness to the 120 VAC terminal on the SMA.
6. Secure 4 pin harness from SMA to terminal on motor.

SYSTEM STATUS LED OVERVIEW

IMPORTANT: For easy identification, place accompanying System Status label on the top facing surface of control box.

LED COLORS AND DEFINITIONS

- YELLOW** Torque limit of motor has been reached
- BLUE** Power supply is connected
- GREEN** *Solid Light* - Cover is ready for operation
Flashing Light - Motor is running
- RED** Cover has traveled as far as possible in the direction moving

TECHNICAL SUPPORT

If you have any questions about these installation procedures, please contact Technical Support (800) 878-5789.

LABEL PLACEMENT

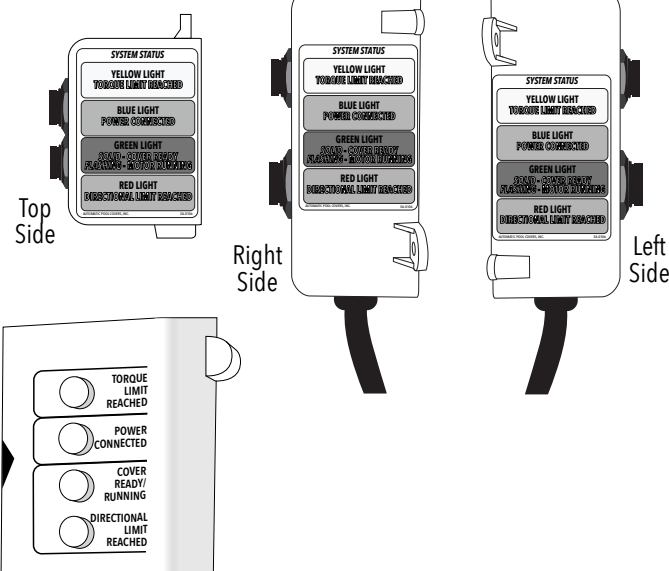

Automatic Pool Covers, Inc.

(800) 878-5789 • automaticpoolcovers.com

HYDRAULIC TOUCH PAD WIRING

120 VAC/60Hz

WARNING



WARNING

Do not attempt to connect, or disconnect, the control unit or motor harness while supply power is ON. Doing so can irreversibly damage controller and cover motor, and potentially cause serious injury or death.

SYSTEM LAYOUT

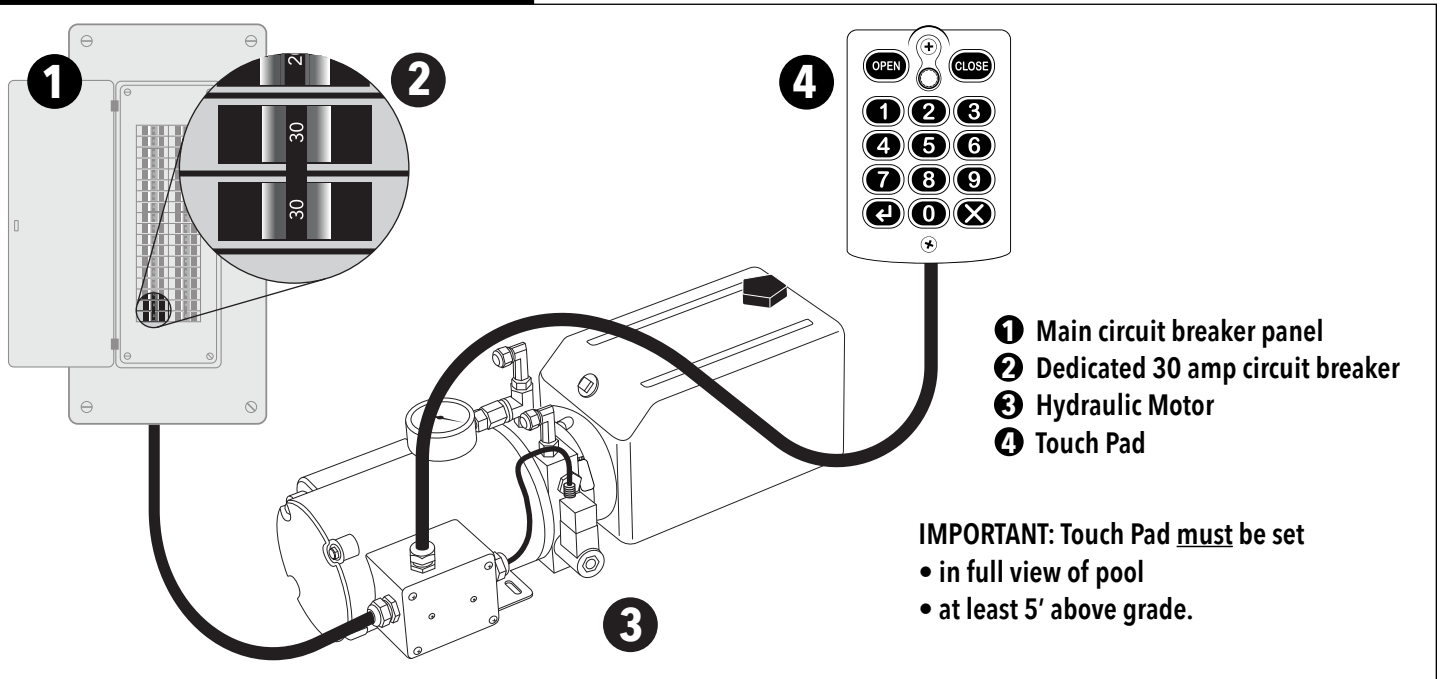

CONTROLLER CONNECTIONS

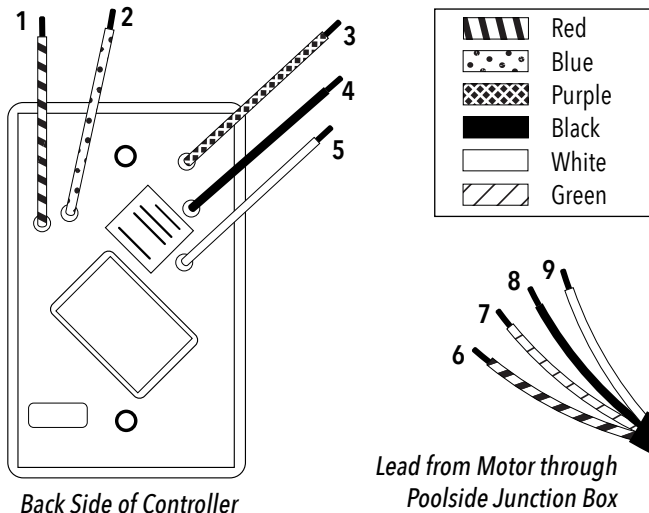

Connect supply power and control wires to appropriate leads located on the rear of the controller base.

CONNECTION GUIDE	
Touch Pad	Supply Power
Red (1)	to Red (6)
Blue (2) - capped	
Purple (3)	to Green (7)
Black (4)	to Black (8)
White (5)	to White (9)

CONTROLLER OPERATION

Be sure all electrical connections within their respective junction boxes are secure with appropriate hardware.

1. Enter code **1 2 3 4**
2. Press "Enter" **✓**
3. Press **OPEN** or **CLOSE** to move cover in the desired direction.
4. Press the **X** button to disable touchpad. The touchpad will automatically shut off in 20 seconds.

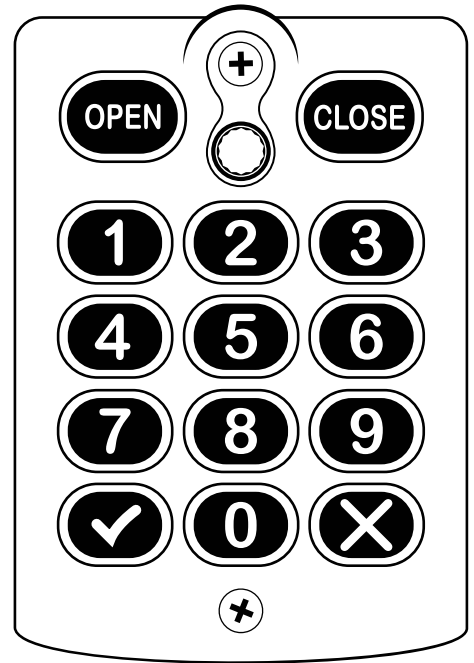

CHANGING THE CODE

The default code, preset at the factory, **1 2 3 4** works for all new controllers

1. Press and hold **✓** until **RED** light glows.
2. Enter new desired 4 number code.
3. The **RED** light will turn off when the new code has been accepted. The controller is ready for normal use.

ENTERING SERVICE CODE

The Service Code allows access to the touch pad without modifying or knowing owner's code.

1. Press and hold the **✓** button until **RED** light glows.
2. Wait 2 seconds then press and hold the **✓** button until the **RED** light starts to flash.
3. Input Service Code **9 0 0 1** then hit the **✓** button.
4. The **RED** light will turn off and the **GREEN** light will glow.
5. The cover can be opened closed by pressing the appropriate button on the pad, **OPEN** or **CLOSE**

NOTE: The touch pad will automatically shut off in 10 minutes if the cover is not run or disabled.

TECHNICAL SUPPORT

If you have any questions about these installation procedures, please contact Technical Support at (800) 878-5789.

Automatic Pool Covers^{Inc.}

(800) 878-5789 • automaticpoolcovers.com

KEYSWITCH WIRING
Hydraulic Motor Connection

INSTRUCTIONS

Note: Do not disconnect or remove the jump wires that are already connected to the switch.

Step 1 With the keyswitch turned so the Bottom is facing you, connect the WHITE wire from the 18 AWG/4C cable to the top right terminal of the Upper Block by loosening then tightening the terminal screw.

Step 2 On the opposite side of the switch, connect the RED wire to either of the bottom terminals (A or B) on the Lower Block in the same manner. If cover movement does not match "OPEN/CLOSE" indications on the on keyswitch cover plate, switch wire to the opposite terminal.

Step 3 Connect the BLACK wire from the 18AWG/4C cable to the upper left terminal of the Upper Block in the same way.

Step 4 Operate switch, if cover movement is opposite of the direction indicator on the front of the keyswitch, switch the RED wire to the opposing terminal.

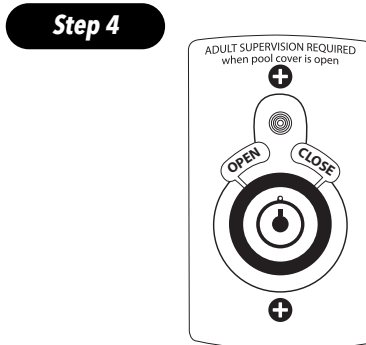
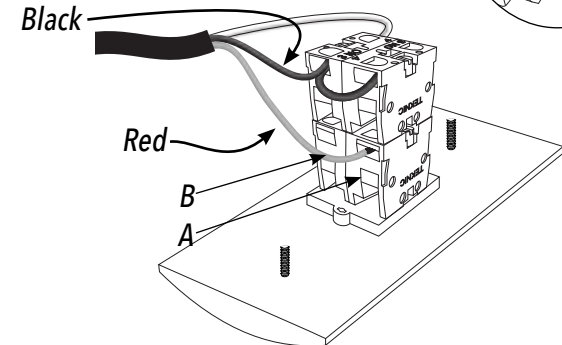
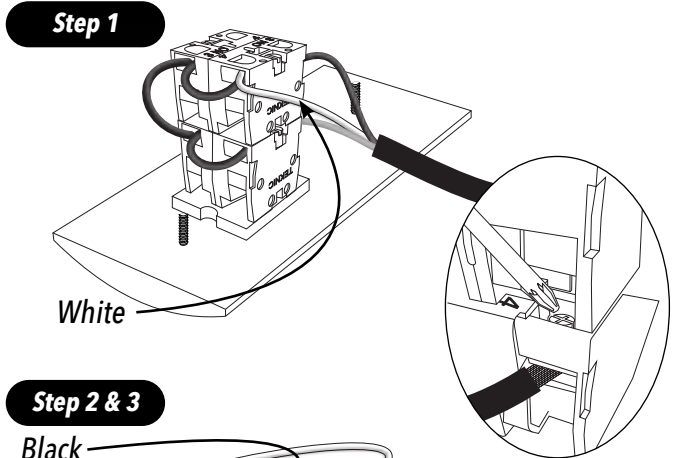
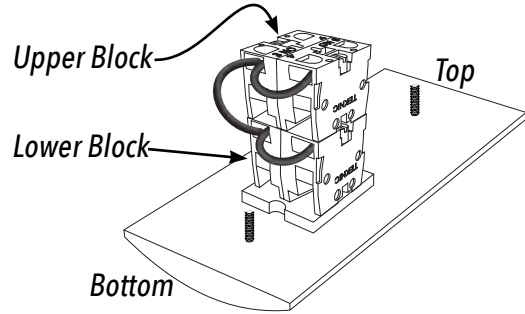







TECHNICAL SUPPORT

If you have any questions about these installation procedures, please contact Technical Support (800) 878-5789 Monday through Friday.

SERVICE SWITCH

EA-0112 Instructions

INSTRUCTIONS

1. Remove the original 4 pin harness (female) from the motor.
2. Connect the removed 4 pin harness (female) to the male connector on the Service Switch.
3. Connect the 4 pin harness (female) from the Service Switch to the motor (male).
4. At the poolside touch pad, hold the  button until **RED** light appears.
5. When **RED** light appears, release the  and push again until **RED** light begins to flashing.
6. While **RED** light is flashing, enter     to send power to run the service switch.
7. When service is complete, return to the poolside touch pad location and hit the  button to turn the power off.
8. Remove the motor harness from the service switch and service switch harness off of motor.
9. Reinstall original motor harness back on motor.

NOTE: Touch pad must be turned off before attaching motor harness back to motor.

Step 1

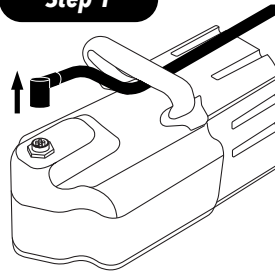

Step 2

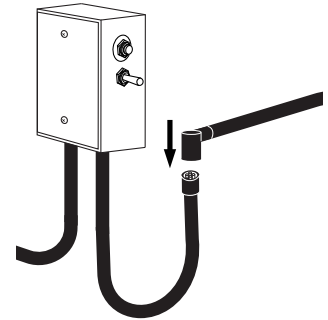

Step 3

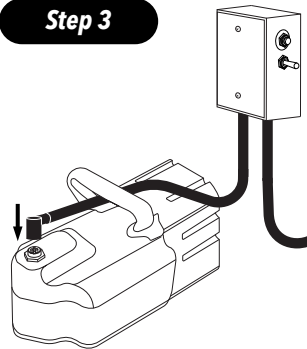

Step 4 - 7

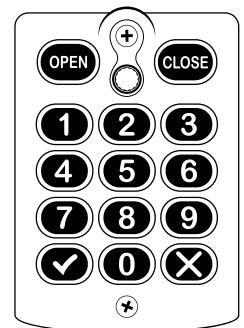

Step 8

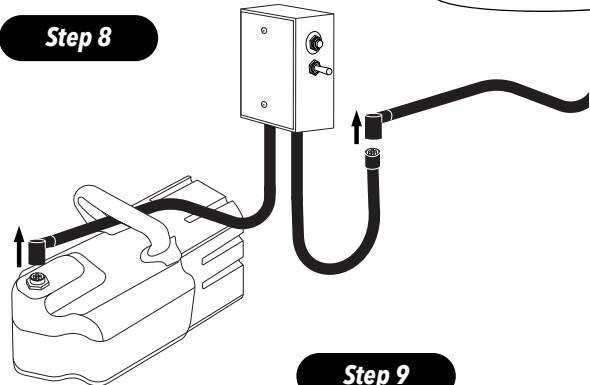

Step 9

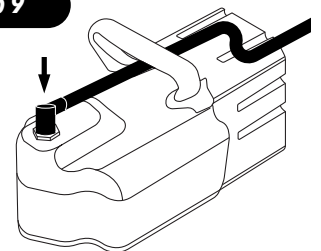

TECHNICAL SUPPORT

If you have any questions about these installation procedures, please contact Technical Support (800) 878-5789 Monday through Friday, 8 am - 5 pm EST.

ELECTRICAL DIAGRAM
Wiring Cover Pools KOSA Switch

WARNING



Do not attempt to connect, or disconnect, the control unit or motor harness while supply power is ON. Doing so can irreversibly damage controller and cover motor, and potentially cause serious injury or death.

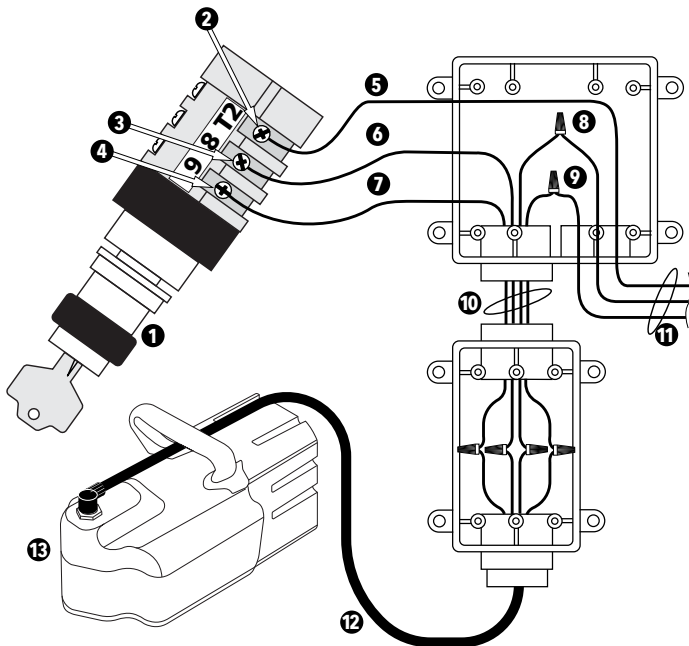

1. KOSA Key Switch
2. T2 Terminal
3. T8 Terminal
4. T9 Terminal
5. Power Source - Hot
6. RED Motor Wire to T8 ③
7. BLACK Motor Wire to T9 ④
8. WHITE Motor Wire to Neutral ⑧
9. GREEN Motor Wire to Ground ⑨
10. Wires Supplied from Switch to Motor
11. Power Source Wires (Hot, Neutral, Ground)
12. Wire Harness
13. Motor

Note: To change motor direction, wire:
Red (Motor) to Blue / Black (Motor) to Red

IMPORTANT

- Connect harness so cord faces toward handle.
- Do not force connector onto terminal.
- Use orienting slot to insure proper connection.

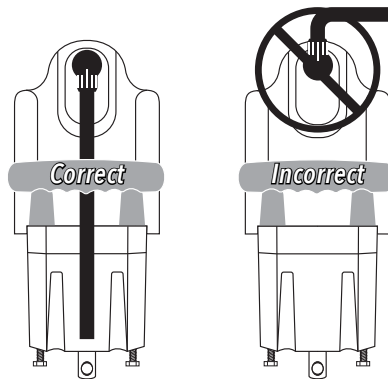
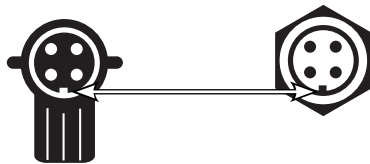

TECHNICAL SUPPORT

If you have any questions about these installation procedures, please contact Technical Support (800) 878-5789 Monday through Friday, 8 am - 5 pm EST.

ELECTRICAL DIAGRAM
Wiring Coverstar Leviton Switch

WARNING



WARNING

Do not attempt to connect, or disconnect, the control unit or motor harness while supply power is ON. Doing so can irreversibly damage controller and cover motor, and potentially cause serious injury or death.

SYSTEM OVERVIEW

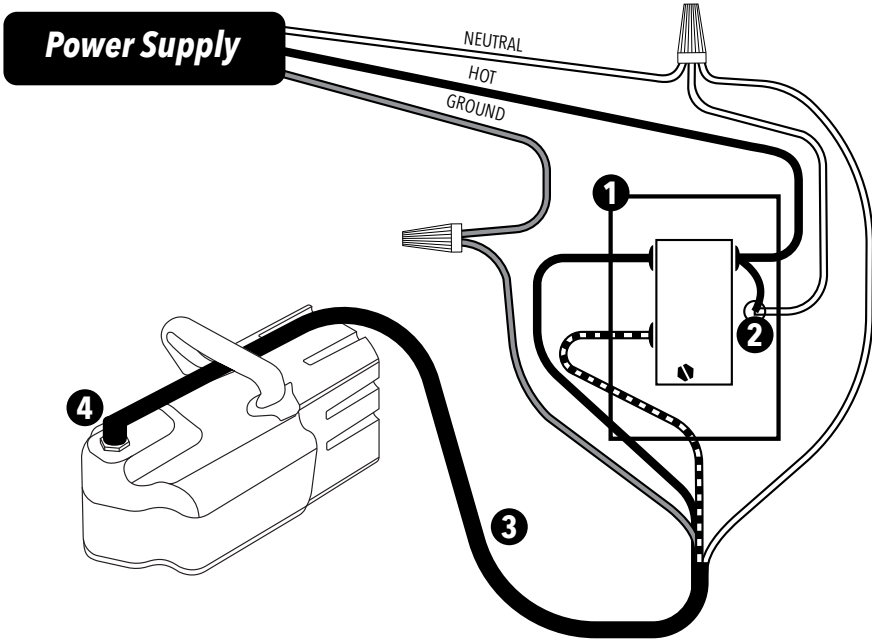

- 1. Coverstar Key Switch
- 2. Light
- 3. Motor Harness
- 4. APC PowerTouch Motor



IMPORTANT

- Connect harness so cord faces toward handle.
- Do not force connector onto terminal.
- Use orienting slot to insure proper connection.

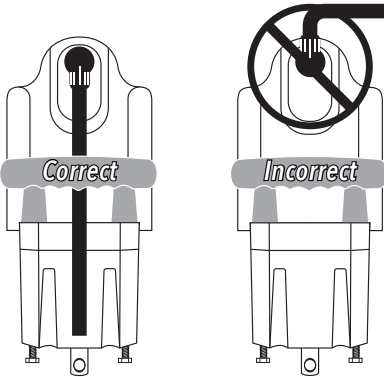

TECHNICAL SUPPORT

If you have any questions about these installation procedures, please contact Technical Support (800) 878-5789 Monday through Friday, 8 am - 5 pm EST.

ELECTRICAL BONDING KIT

KA-0192 Instructions

PARTS IDENTIFICATION

Item	Qty	Part#	Description
A	2	HC-0113	Grounding Lug
B	2	EC-0251	4" Copper Wire

INSTRUCTIONS

Motor End

1. Place one Grounding Lug on top of the guide, and fasten the guide together with hardware supplied with guide.
2. Slide end of wire into Grounding Lug and secure in place by tightening the screw on top of lug.
3. Run Copper Wire around to the front side of the motor end and slide the end of the copper wire into the factory installed lug on the motor mounting bracket.

Opposite End

1. Place one Grounding Lug on top of the guide, and fasten the guide together with hardware supplied with guide.
2. Slide end of wire into Grounding Lug and secure in place by tightening the screw on top of lug.
3. Run Copper Wire around to the back side of the opposite end and slide the end of the copper wire into the factory installed lug on the opposite end frame.

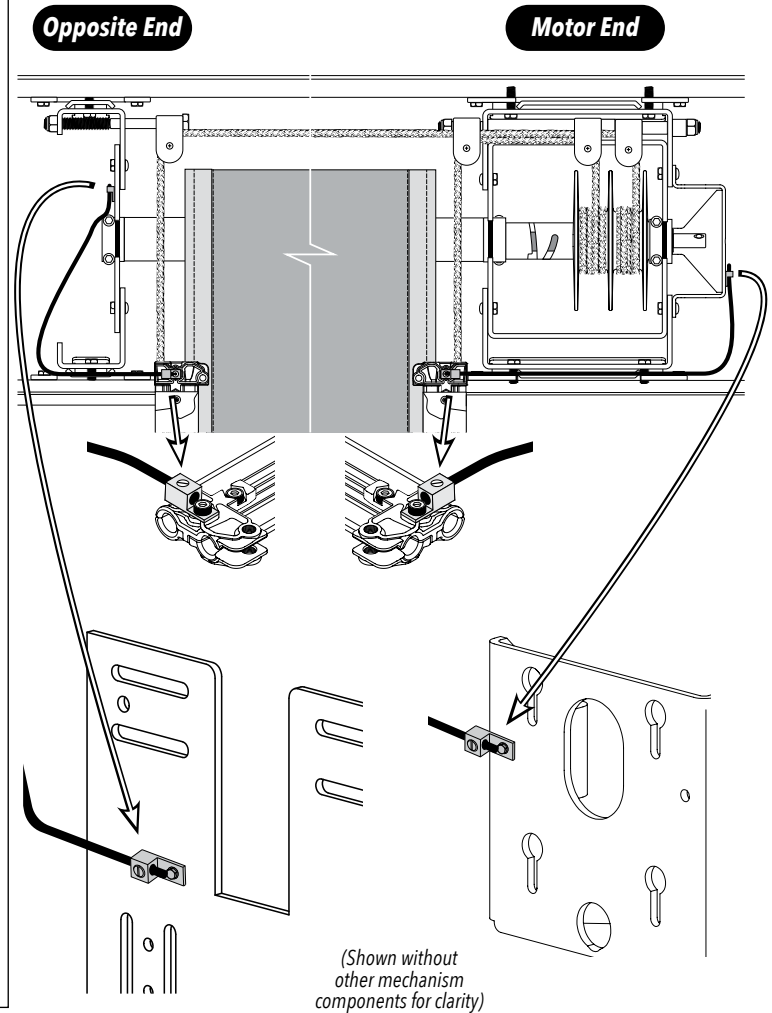
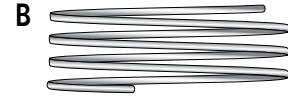
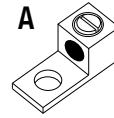

TECHNICAL SUPPORT

If you have any questions about these installation procedures, please contact Technical Support (800) 878-5789 Monday through Friday, 8 am - 5 pm EST.

BRACKET HOLE USES

Hole	Use
A	For use with <i>Standard Rope Bead Cover</i>
B	For use when cover has a <i>Loop On The Front</i>
C	For use with covers using <i>3-Channel Track</i>

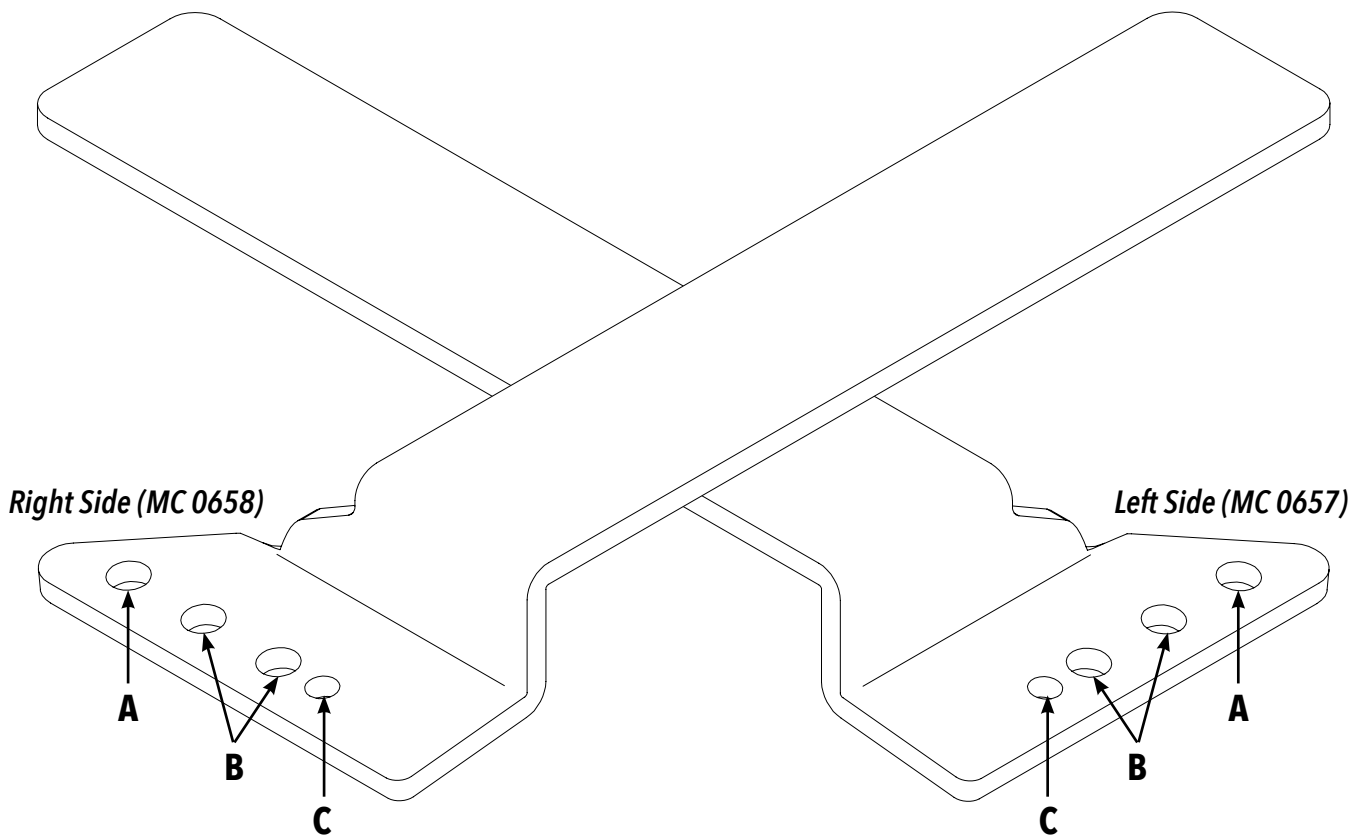

TECHNICAL SUPPORT

If you have any questions about these installation procedures, please contact Technical Support (800) 878-5789 Monday through Friday.

ROPE REPAIR KIT KA-0189 Instructions

TOOLS & PART IDENTIFICATION

5/32" Drill Bit Lighter/flame
Scissors/knife Replacement Rope

Part Qty	APC #	Description
A 8	HC-0249	Glider Screw
B 2	MC-0601	Universal Glider Body
C 2	HC-0024	Hex Head Cap Screw (5/16-18 UNC x 1.00, S/S)
D 2	HC-0092	Washer (5/16, S/S)
E 2	HC-0058	Nylock Nut (5/16-18 UNC, S/S)

INSTRUCTIONS

NOTE: Be sure to keep open flame away from vinyl pool cover.

- To make it easier for the rope to be inserted into the groove of the glider, carefully heat approximately 1.5" of the end of the replacement rope with a flame to slightly melt the rope.
 - To make a clean cut on the end, and to eliminate the need for the rope end to be melted, blacken a small section of the rope where the cut is to be made with the open flame.
 - When rope has cooled, slide 1.5" of the end of the rope into the "Lead Edge" end of the groove of the Universal Glider Body (B).
 - Locate two Glider Screws (A). Insert a screw into the 2nd and one in the 3rd hole from the end. Screwing through the rope and tightening into the glider body. The screw head should be flush to, or slightly below the outside surface of the edge of the glider. **Do not over tighten!**
 - Heat an approximate 2" section of rope near where it is connected to the cover.
 - To make a clean cut back from the cover, and to eliminate the need for the rope end to be melted, blacken a small section of the rope where the cut is to be made with the open flame.
 - When rope has cooled, slide the end of the rope into the "Cover Side" end of the groove of the glider 1.5".
 - Locate two Glider Screws (A). Insert a screw into the 2nd and one in the 3rd hole from the end. Screwing through the rope and tightening into the glider body. The screw head should be flush to, or slightly below the outside surface of the edge of the glider. **Do not over tighten!**
 - Attach the glider body to the Lead Edge with the Hex Head Cap Screw (C), Washer (D) and Nylock Nut (E)
- Note: Bracket must slide freely.**
- Insert the rounded end of the glider body (with the ropes) into the pool cover track.
 - Repeat procedure on other side of cover.

For Standard Channel Track (XC-0007)

This is intended to be a temporary (2-3 years) repair to maximize the life of the pool cover.

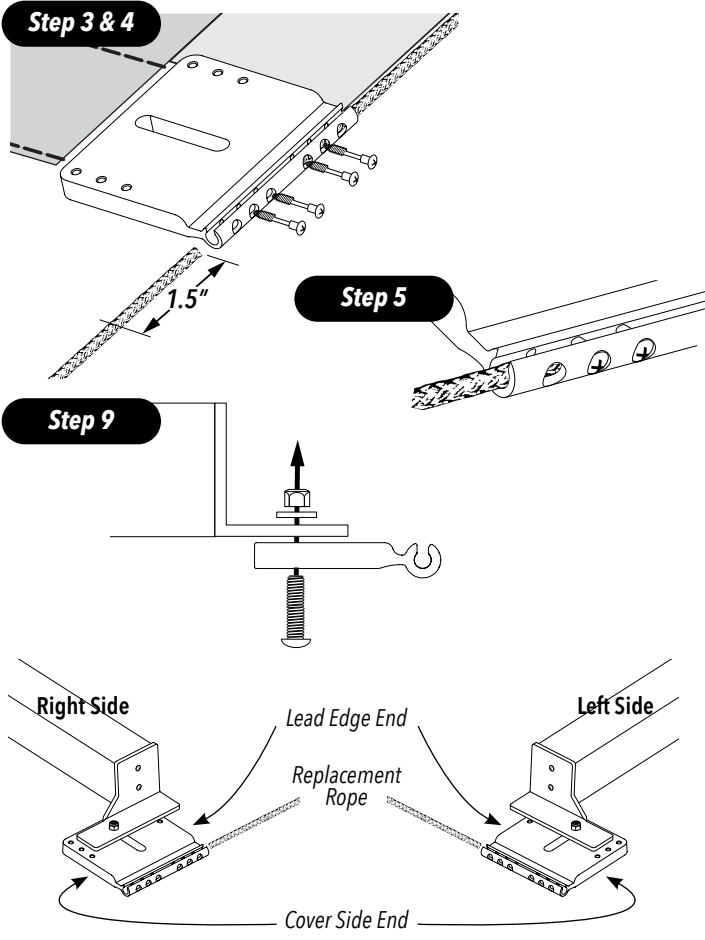
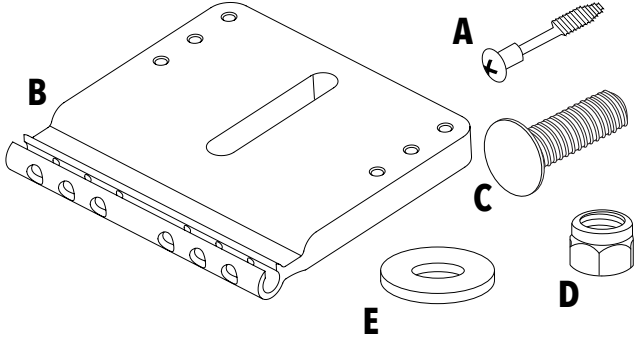

TECHNICAL SUPPORT

If you have any questions about these installation procedures, please contact Technical Support (800) 878-5789 Monday through Friday, 8 am - 5 pm EST.

TOOLS & PART IDENTIFICATION

1. 5/32" Drill Bit
2. Lighter/flame
3. Scissors/knife
4. Replacement Rope

Part Qty	APC #	Description
A 8	HC 0249	Glider Screw
B 2	MC 0618	Under Track Torque Limit Glider Body
C 2	HC 0058	Hex Head Cap Screw (5/16-18 UNC x 1.00, S/S)
D 2	HC 0092	Washer (5/16, S/S)
E 2	HC 0002	Nylock Nut (5/16-18 UNC, S/S)

INSTRUCTIONS

NOTE: Be sure to keep open flame away from vinyl pool cover.

NOTE: DO NOT CUT ROPES if only replacing gliders.

- Step 1** To make it easier for the rope to be inserted into the groove of the glider, carefully heat approximately 1.5" of the end of the replacement rope with a flame to slightly melt the rope.
 - Step 2** To make a clean cut on the end, and to eliminate the need for the rope end to be melted, blacken a small section of the rope where the cut is to be made with the open flame.
 - Step 3** When rope has cooled, slide 1.5" of the end of the rope into the "Lead Edge" end of the groove of the Torque Limit Glider Body (B).
 - Step 4** Locate two Glider Screws (A). Insert a screw into the 2nd and one in the 3rd hole from the end. Screwing through the rope and tightening into the glider body. The screw head should be flush to, or slightly below the outside surface of the edge of the glider. **Do not over tighten!**
 - Step 5** Heat approximate 2" section of rope near where it is connected to the cover.
 - Step 6** To make a clean cut back from the cover, and to eliminate the need for the rope end to be melted, blacken a small section of the rope where the cut is to be made with the open flame.
 - Step 7** When rope has cooled, slide the end of the rope into the "Cover Side" end of the groove of the glider 1.5".
 - Step 8** Locate two Glider Screws (A). Insert a screw into the 2nd and one in the 3rd hole from the end. Screwing through the rope and tightening into the glider body. The screw head should be flush to, or slightly below the outside surface of the edge of the glider. **Do not over tighten!**
 - Step 9** Attach the glider body to the Lead Edge with the Hex Head Cap Screw (C), Washer (D) and Nylock Nut (E)
- Note: Bracket must slide freely.**
- Step 10** Insert the rounded end of the glider body (with the ropes) into the pool cover track.
 - Step 11** Repeat procedure on other side of cover.

TECHNICAL SUPPORT

If you have any questions about these installation procedures, please contact Technical Support (800) 878-5789 Monday through Friday, 8 am - 5 pm EST.

ROPE REPAIR KIT

KA0190 Instructions

For Large Channel Track (XC0054)

This is intended to be a temporary (2-3 years) repair to maximize the life of the pool cover.

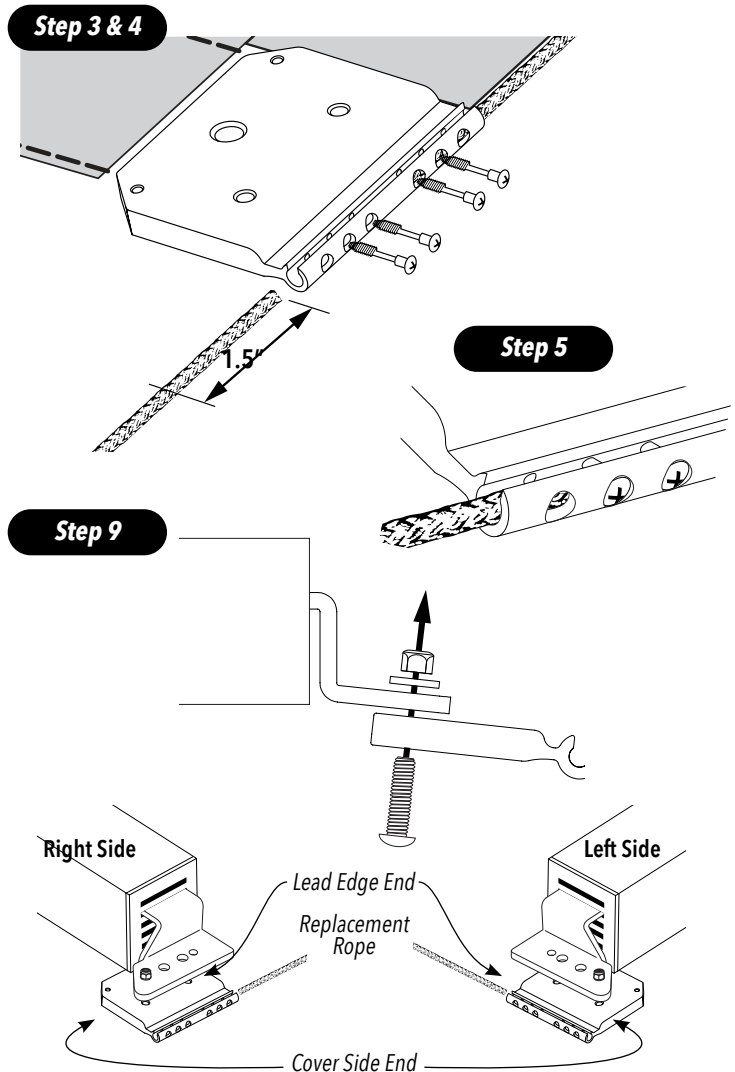
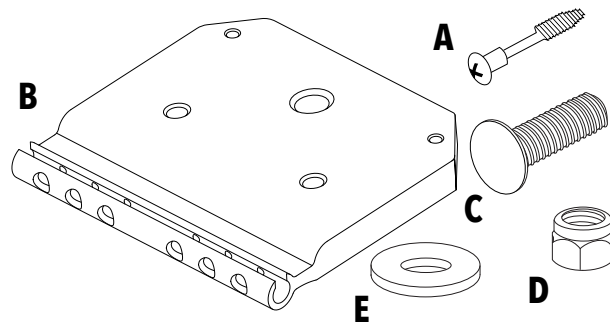

TOP TRACK CARRIAGE

KA-0185 Instructions

TOOLS

1. Drill
2. Wrenches/sockets: 7/16", 1/2"
3. Allen Wrench: 1/8", 5/32"
4. Philips Screwdriver
5. Drill Bits: 5/32", 5/16", 1/4"

PARTS IDENTIFICATION

Part Qty	APC #	Description
A 2	MC-0541	Lead Edge Bracket
B 2	MC-0548	Rope Slider
C 2	MC-0542	Carriage Plate
D 2	MC-0546	Carriage
E 2	MC-0547	Track Slider
F 8	HC-0036	Oval Head Philips Screw (#12 x 2.50, S/S)
G 8	HC-0058	Hex Head Cap Screw (5/16-18 UNC x 1.00 S/S)
H 4	HC-0020	Hex Head Cap Screw (1/4-20 UNC x 0.75 S/S)
I 4	HC-0227	Flat Head Cap Screw (#10-24 UNC x 0.5, 18-8 S/S)
J 8	HC-0025	Split Lock Washer (5/16, 18-8 S/S)
K 8	HC-0057	Hex Nut (5/16-18 UNC, 18-8 S/S)
L 8	HC-0106	#12 Anchor
M 4	MC-0477	Hard Stop
N 2	MC-0352	Adj. Lead Edge Dowel
O 2	HC-0038	Pan Head Philips Screw (#10 x 0.50 SMS, 18-8 S/S)
(Parts required but not included in KA-0185 Kit)		
P 2	HC-0230	Button Head Allen Screw (1/4-20 UNC x 0.63, 18-8 S/S)
Q 2	HC-0229	Flat Head Allen Screw (1/4-20 x UNC 0.75, 18-8 S/S)
R 2	MC-0551	Metal Rope Guide
S 2	MC-0552	Metal Rope Guide

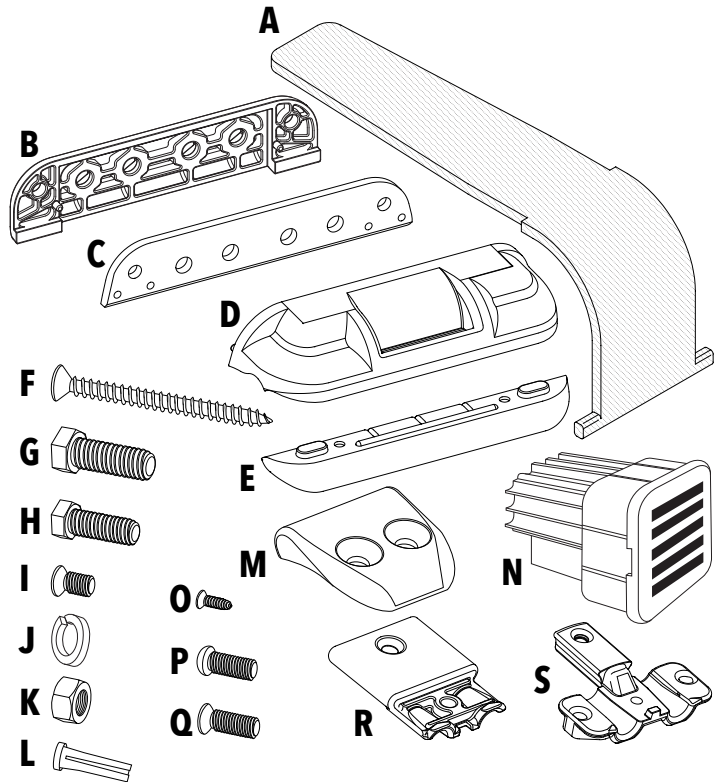

Step 1 & 2

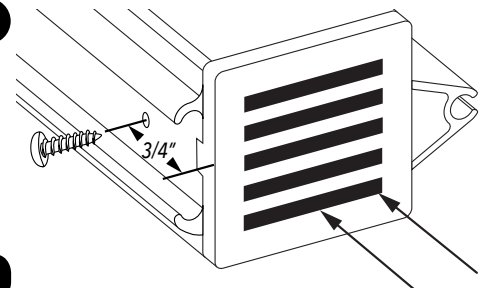

Step 3

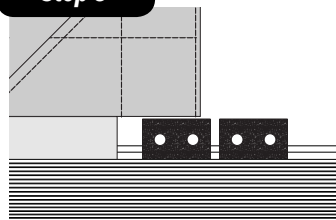

INSTRUCTIONS

1. Insert the Adjustable Lead Edge Dowel (N) in the end of the Square Lead Edge.
2. Locate a Pan Head Philips Screw (O). Drill a 5/32" pilot hole 3/4" in from the end of the Dowel to prevent the Adjustable Dowel from coming out of the Lead Edge.
3. After Top Tracks have been properly installed, insert the Invis-A-Rope attached to the cover into the Front Channel of the track (the channel the cover slides into.)

INSTRUCTIONS

4. Locate one of the Rope Sliders (B) and four Hex Head Cap Screws (G). Insert the Screws into the holes in the Rope Slider.
5. Locate a Carriage Plate (C), four Hex Nuts (K) and four Split Lock Washers (J). Place the sewn-in tabs onto the Screws inserted into the Rope Slider.
6. Slide the Carriage Plate over the Screws inserted into the Rope Slider, squeezing the sewn-in tabs between, with the chamfered edge facing away from the pool. Add a Split Lock Washer and a Hex Nut to each Screw. Tighten bolts. **DO NOT OVER TIGHTEN.**
7. Locate a Lead Edge Bracket (A) and a Carriage (D). Slide the small end of the Bracket in through the slot in the Carriage. Fully insert the Bracket so the tabs on the end fit into the stops in the Carriage.
8. Locate a Track Slider (E) and two Flat Head Cap Screws (I). Insert the guide tabs on the Track Slider into the corresponding holes in the Carriage. Secure them together with the Flat Head Cap Screws.
9. Join the Carriage Assembly with the Rope Slider/Carrier Plate Assembly by inserting the small round tabs on the Carriage into the outermost holes in the Carriage Plate.
10. Locate two Hex Head Cap Screws (H), and insert them into the outermost holes in the Rope Slider side of the Carriage Assembly. Tighten bolts. **DO NOT OVER TIGHTEN.**

Step 4

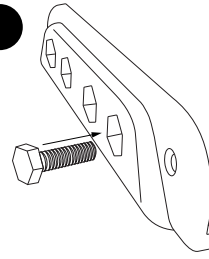

Step 5&6

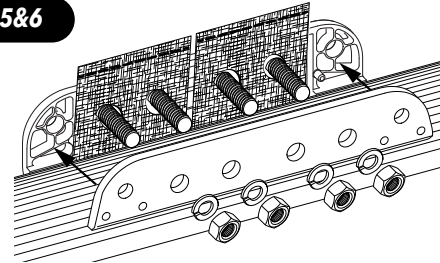

Step 7

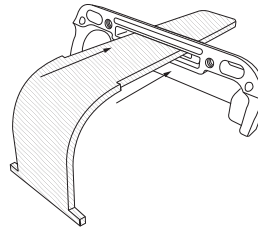

Step 8

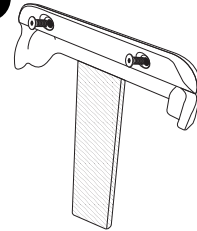

Step 9

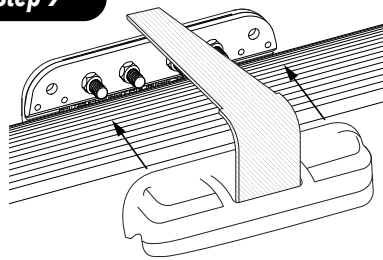

Step 10

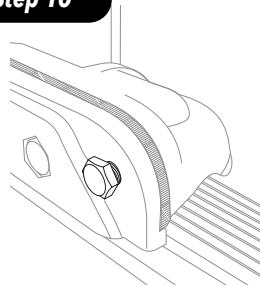

INSTRUCTIONS

11. Locate the bottom half of the Metal Rope Guide (S). Position Guide with the rope in one slot and the rope sewn into the webbing of the cover into the other slot.
12. Slide the end of the Metal Rope Guide into the center channel on the underside of the track.
13. Locate the top half of the Metal Rope Guide (R). Position it on the bottom half and mark the center of the hole on the track.
14. Remove the Metal Rope Guides and drill a hole as marked in Step 14 with a 5/16" drill bit.
15. Reinsert the bottom half of the Metal Rope Guide. Position the ropes, then position the top half of the Metal Rope Guide on the bottom half. Secure the halves together with Button Head Allen Screw (P) in the hole closest to the end, and the Flat Head Allen Screw (Q) in the hole drilled through the track.
16. Locate two Hard Stops (M), four Oval Head Phillips Screws (F) and four #12 Anchors (L). Position one Hard Stop near the far end of the track, and the other near the cover lid. Lay the stop so the thicker end is flush with the front channel and the holes are at the center of the track. Mark the two hole locations. With 1/4" masonry bit, drill holes into the concrete at each location. Insert an Anchor through the track and into the hole, and screw in the Oval Head Phillips Screws.
17. Slide the Lead Edge onto the cover from one end toward the side with the carriage assembled.
18. Insert the end of the Lead Edge Bracket into the slot in the Dowel that matches the measurement from the pool deck to the bottom of the lead edge bar.
19. Repeat steps 3-18 (except Step 17) on the opposite side of pool.

Step 11

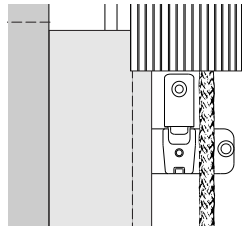

Step 12

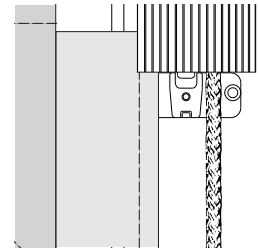

Step 13

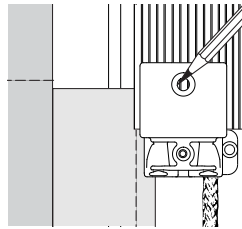

Step 14

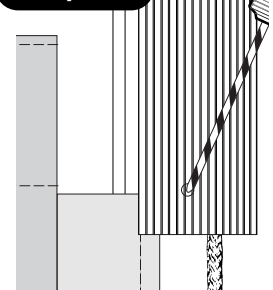

Step 15

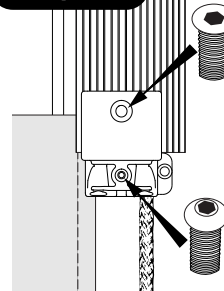

Step 16

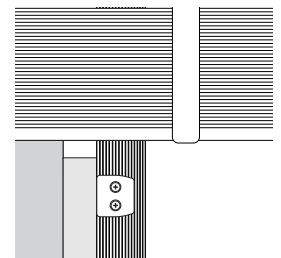
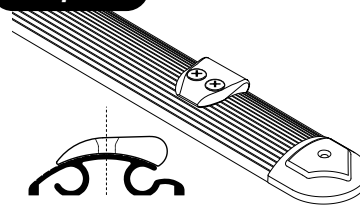

TECHNICAL SUPPORT

If you have any questions about these installation procedures, please contact Technical Support (800) 878-5789 Monday through Friday, 8 am - 5 pm EST.

Automatic Pool Covers, Inc.

(800) 878-5789 • automaticpoolcovers.com

CARRIAGE UPGRADE KIT

Top Track - KA 0354 Instructions

PARTS IDENTIFICATION

Item	Qty	Part#	Description
A	8	HC 0092	Flat Washer, 5/16, 18-8, S/S
B	4	MC 0825	Carriage Wheels
C	4	HC 0321	Nylock Nut, 5/16-8, 18-8, S/S
D	4	HC 0320	Hex Head Cap Screw, 5/16-8 x 1.5", 18-8, S/S
E*	2		Split Lock Washer from MA-0139
F*	2		Hex Head Nut from MA-0139

* reuse from carriage being replaced

INSTRUCTIONS

- Step 1** With Carriage Bracket assembly removed, remove outer two Hex Head Cap Screws with Split Lock Washer (E*) and Hex Head Nut (F*). **Discard screws, but retain the Split Lock Washer and Hex Head Nut.**
- Step 2** Insert new Hex Head Cap Screw (D) through each open hole about half way through.
- Step 3** Reinstall Split Lock Washer from standard assembly over each screw until it stops on plate.
- Step 4** Reinstall Hex Head Nut (F*) from standard assembly over each screw until it stops on split lock washer & hand tighten. **Do not over tighten.**
- Step 5** Slide Flat Washer (A) over each screw until it stops on Hex Head Nut.
- Step 6** Slide Carriage Wheel (B) over each screw until it stops on Flat Washer.
- Step 7** Slide another Flat Washer over each screw until it stops on the Carriage Wheel.
- Step 8** Thread a Nylock Nut (C) on each screw and tighten until it stops on Flat Washer. (Insure head of each screw is seated fully in hex counterbore on outside of bracket before tightening.) **Do not over tighten.**
- Step 9** Back off nut 1/2 turn (180°) to set proper running clearance for each carriage wheel.

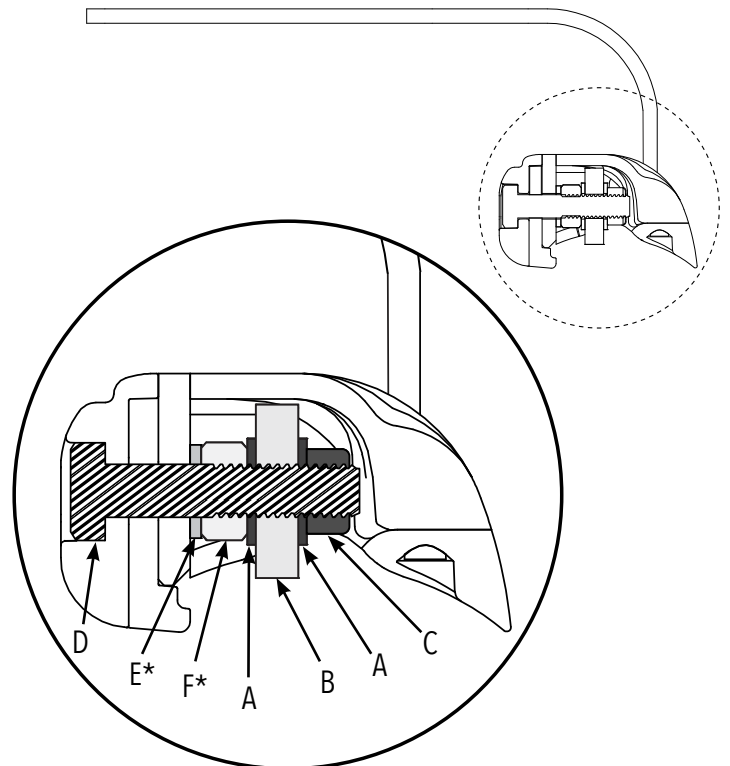
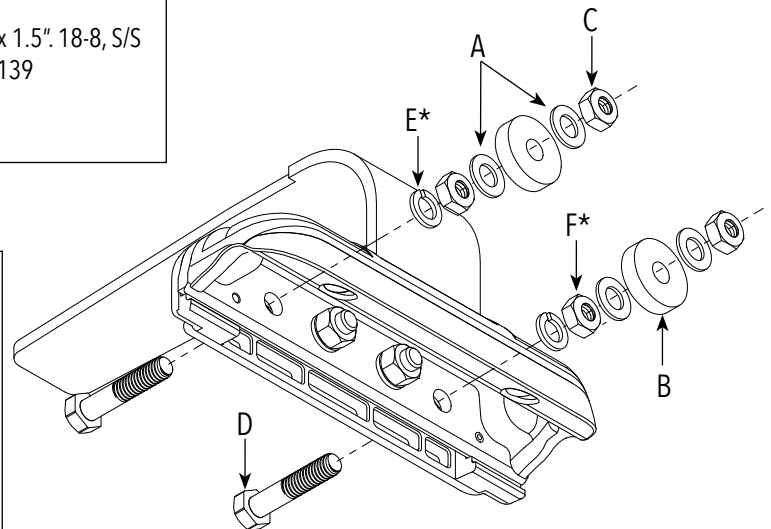

TECHNICAL SUPPORT

If you have any questions about these installation procedures, please contact Technical Support (800) 878-5789 Monday through Friday, 8 am - 5 pm EST.

TOP TRACK CARRIAGE

KA 0378 Round Lead Edge Instructions

TOOLS NEEDED

1. Drill
2. Wrenches/sockets: 7/16", 1/2"
3. Allen wrench: 1/8", 5/32"
4. Phillips screwdriver
5. Drill bits: 5/32", 5/16"
6. Saw with metal blade

PARTS IDENTIFICATION

Part	Qty	APC #	Description
A	2	MC 0541	Lead Edge Bracket
B	2	MC 0548	Rope Slider
C	2	MC 0542	Carriage Plate
D	2	MC 0546	Carriage
E	2	MC 0547	Track Slider
F	8	HC 0036	Oval Head Phillips Screw (#12 x 2.50, S/S)
G	8	HC 0058	Hex Head Cap Screw (5/16-18 UNC x 1.00 S/S)
H	4	HC 0020	Hex Head Cap Screw (1/4-20 UNC x 0.75 S/S)
I	4	HC 0227	Flat Head Cap Screw (#10-24 UNC x 0.5, 18-8 S/S)
J	8	HC 0025	Split Lock Washer (5/16, 18-8 S/S)
K	8	HC 0057	Hex Nut (5/16-18 UNC, 18-8 S/S)
L	8	HC 0106	#12 Anchor
M	4	MC 0477	Hard Stop
N	2	MC 0886	Round Lead Edge Dowel
O	2	HC 0038	Pan Head Phillips Screw (#10 x 0.50 SMS, 18-8 S/S)
(Parts required but not included in KA 0185 Kit)			
P	2	HC 0230	Button Head Allen Screw (1/4-20 UNC x 0.63, 18-8 S/S)
Q	2	HC 0229	Flat Head Allen Screw (1/4-20 x UNC 0.75, 18-8 S/S)
R	2	MC 0551	Metal Rope Guide
S	2	MC 0552	Metal Rope Guide

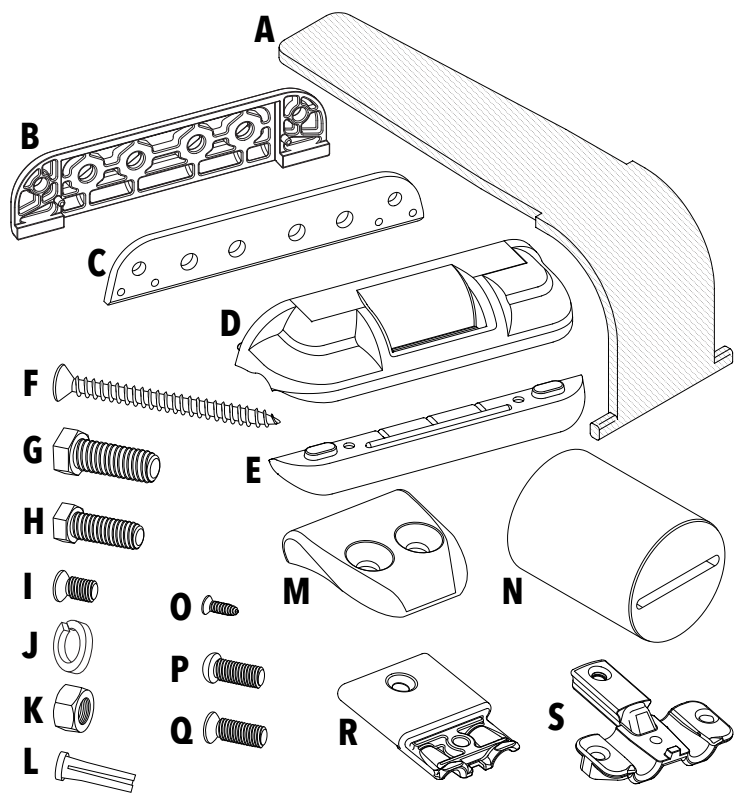

INSTRUCTIONS

- Step 1** Cut Round Lead Edge to 3" less than track space.
- Step 2** Insert the Round Lead Edge Dowel (N) in the end of the Round Lead Edge. Screw two Pan Head Drum Screws (O) through the round lead edge and into the round dowel.
- Step 3** Pull the rope through the channels until the sewn-in tabs on the rope near the cover are at the end of the channel near the cover mechanism.
- Step 4** Slide the tabs into the channel and begin to slide the lead edge for the cover into the channel.
- Step 5** Locate one of the Rope Sliders (B) and four Hex Head Cap Screws (G). Insert the Screws into the holes in the Rope Slider.

Step 2

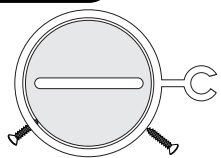

Step 3

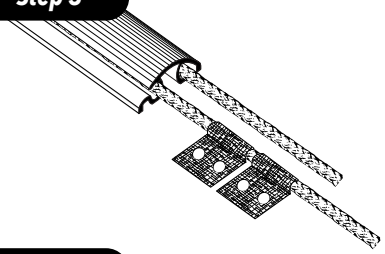

Step 4

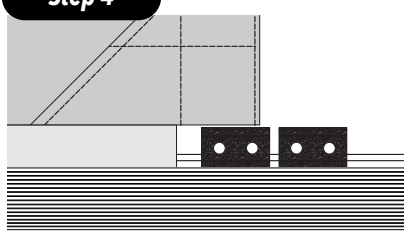

Step 5

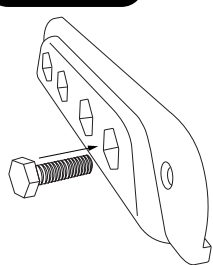

INSTRUCTIONS

Step 6 Locate a Carriage Plate (C), four Hex Nuts (K) and four Split Lock Washers (J). Place the sewn-in tabs onto the Screws inserted into the Rope Slider.

Step 7 Slide the Carriage Plate over the Screws inserted into the Rope Slider, squeezing the sewn-in tabs between, with the chamfered edge facing away from the pool. Add a Split Lock Washer and a Hex Nut to each Screw. Tighten bolts. **DO NOT OVERTIGHTEN.**

Step 8 Locate a Lead Edge Bracket (A) and a Carriage (D). Slide the small end of the Bracket in through the slot in the Carriage. Fully insert the Bracket so the tabs on the end fit into the stops in the Carriage.

Step 9 Locate a Track Slider (E) and two Flat Head Cap Screws (I). Insert the guide tabs on the Track Slider into the corresponding holes in the Carriage. Secure them together with the Flat Head Cap Screws.

Step 10 Join the Carriage Assembly with the Rope Slider/Carrier Plate Assembly by inserting the small round tabs on the Carriage into the outermost holes in the Carriage Plate.

Step 11 Locate two Hex Head Cap Screws (H), and insert them into the outermost holes in the Rope Slider side of the Carriage Assembly. Tighten bolts. **DO NOT OVERTIGHTEN.**

Step 12 Locate the bottom half of the Metal Rope Guide (S). Position Guide with the rope in one slot and the rope sewn into the webbing of the cover into the other slot.

Step 13 Slide the end the Metal Rope Guide into the center channel on the underside of the track.

Step 14 Locate the top half of the Metal Rope Guide (R). Position it on the bottom half and mark the center of the hole on the track.

Step 6 & 7

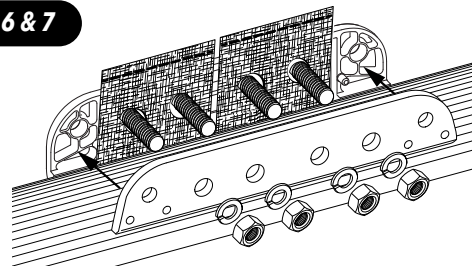

Step 8

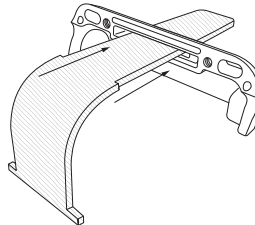

Step 9

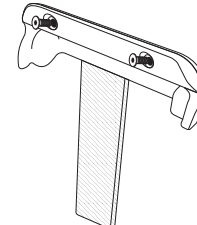

Step 10

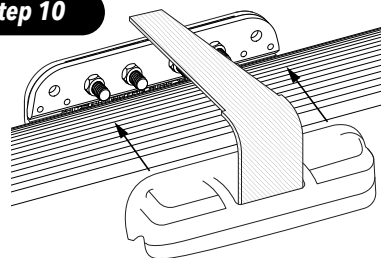

Step 11

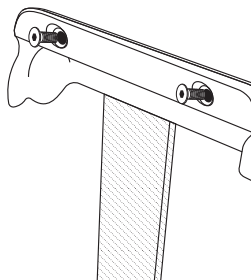

Step 12

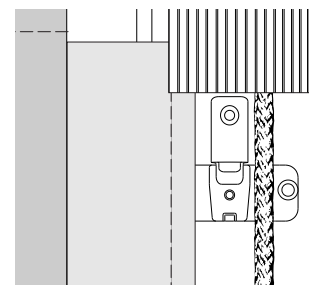

Step 13

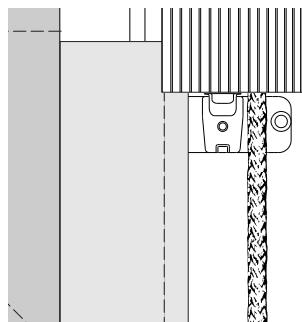

Step 14

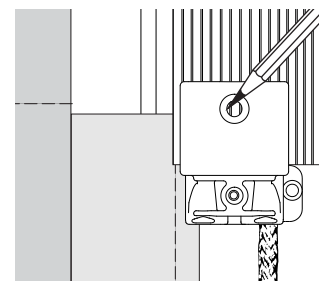

INSTRUCTIONS

Step 15 Remove the Metal Rope Guides and drill a hole as marked in Step 14 with a 5/16" drill bit.

Step 16 Reinsert the bottom half of the Metal Rope Guide. Position the ropes, then position the top half of the Metal Rope Guide on the bottom half. Secure the halves together with Button Head Allen Screw (P) in the hole closest to the end, and the Flat Head Allen Screw (Q) in the hole drilled through the track.

Step 17 Locate two Hard Stops (M), four Oval Head Phillips Screws (F) and four #12 Anchors (L). Position one Hard Stop near the far end of the track, and the other near the cover lid. Lay the stop so the thicker end is flush with the front channel and the holes are at the center of the track. Mark the two hole locations. With a 1/4" masonry bit, drill holes into the concrete at each location. Insert an Anchor through the track and into the hole, and screw in the Oval Head Phillips Screws.

Step 18 Slide the lead edge onto the front of the cover. Insert the end of the Lead Edge Bracket into the slot in the Dowel.

Step 19 Repeat steps Step 2- 17, on the opposite side of pool.

Step 15

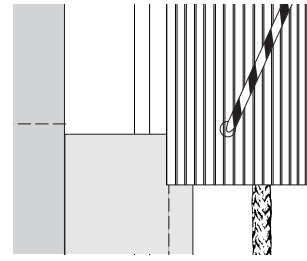

Step 16

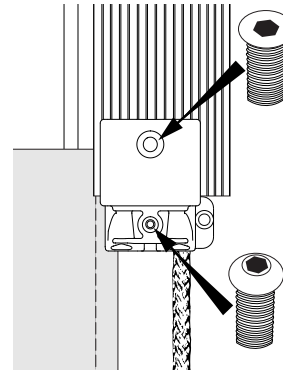

Step 17

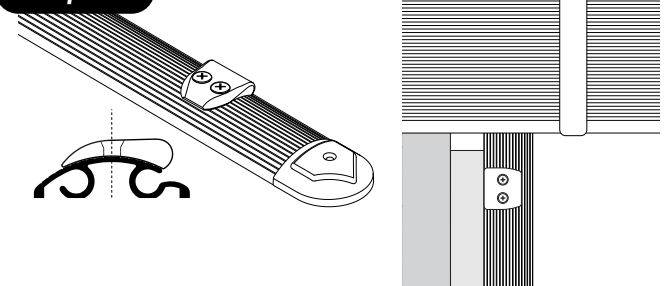

Step 18

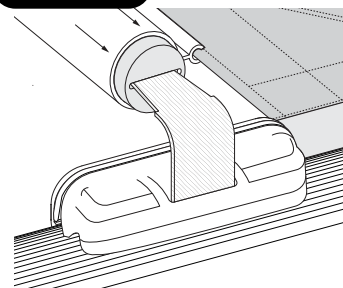

TECHNICAL SUPPORT

If you have any questions about these installation procedures, please contact Technical Support (800) 878-5789 Monday through Friday.

Automatic Pool Covers^{Inc.}

(800) 878-5789 • automaticpoolcovers.com

FLUSH TRACK CARRIAGE

KA 0427 Instructions

TOOLS NEEDED

1. Drill
2. Wrenches/sockets: 7/16", 1/2"
3. Allen wrench: 1/8", 5/32"
4. Phillips screwdriver
5. Drill bits: 5/32", 1/4"

PARTS IDENTIFICATION

Part	Qty	APC #	Description
A	2	MC 0541	Lead Edge Bracket
B	2	MC 0548	Rope Slider
C	2	MC 0542	Carriage Plate
D	2	MC 0546	Carriage
E	2	MC 0924	Track Slider
F	8	HC 0036	Oval Head Phillips Screw (#12 x 2.50, S/S)
G	8	HC 0058	Hex Head Cap Screw (5/16-18 UNC x 1.00 S/S)
H	4	HC 0020	Hex Head Cap Screw (1/4-20 UNC x 1.00 S/S)
I	4	HC 0227	Flat Head Cap Screw (#10-24 UNC x 0.5, 18-8 S/S)
J	8	HC 0025	Split Lock Washer (5/16, 18-8 S/S)
K	8	HC 0057	Hex Nut (5/16-18 UNC, 18-8 S/S)
L	8	HC 0106	#12 Anchor
M	2	HC 0038	Pan Head Phillips Screw (#10 x 0.50 SMS, 18-8 S/S)
N	4	MC 0972	Hard Stop
O	2	MC 0352	Adj. Lead Edge Dowel

(Parts required but not included in KA0187 Kit)

P	1	HC 0673	Metal Rope Guide - Top Left
Q	1	MC 0674	Metal Rope Guide - Bottom Left
R	1	MC 0675	Metal Rope Guide - Top Right
S	1	MC 0676	Metal Rope Guide - Bottom Right

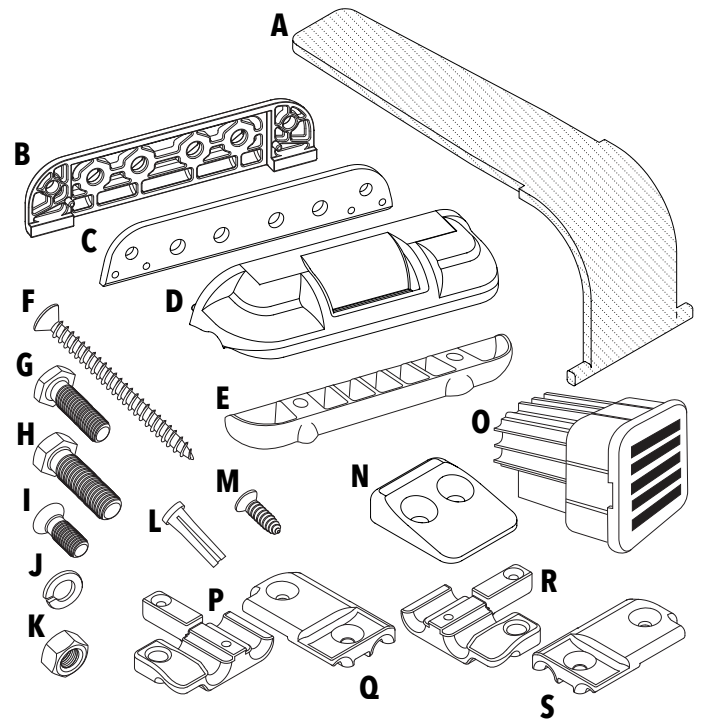

Step 1

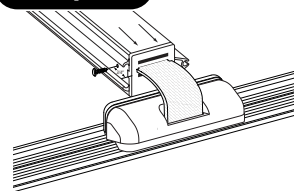

Step 2

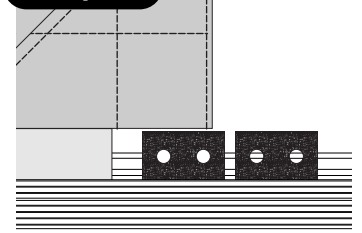

Step 4 & 5

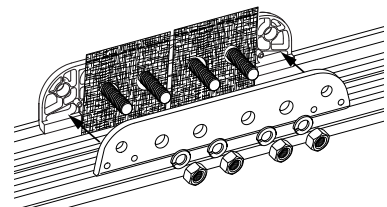

INSTRUCTIONS

- Step 1** Insert the Adjustable Lead Edge Dowel (O) in the end of the Square Lead Edge. Secure Dowel with Pan Head Phillips Screw (M). Drill a 5/32" pilot hole 3/4" in from the end of the Dowel to prevent the Adjustable Dowel from coming out of the Lead Edge.
- Step 2** Slide the tabs into the channel.
- Step 3** Locate one of the Rope Sliders (B) and four Hex Head Cap Screws (G). Insert the Screws into the holes in the Rope Slider.
- Step 4** Locate a Carriage Plate (C), four Hex Nuts (K) and four Split Lock Washers (J). Place the sewn-in tabs onto the Screws inserted into the Rope Slider.
- Step 5** Slide the Carriage Plate over the Screws inserted into the Rope Slider, squeezing the sewn-in tabs between, with the chamfered edge facing away from the pool. Add a Split Lock Washer and a Hex Nut to each Screw. Tighten bolts. **DO NOT OVER TIGHTEN.**

INSTRUCTIONS

Step 6 Locate a Lead Edge Bracket (A) and a Carriage (D). Slide the small end of the Bracket in through the slot in the Carriage. Fully insert the Bracket so the tabs on the end fit into the stops in the Carriage.

Step 7 Locate a Track Slider (E) and two Flat Head Cap Screws (I). Insert the guide tabs on the Track Slider into the corresponding holes in the Carriage. Secure them together with the Flat Head Cap Screws.

Step 8 Join the Carriage Assembly with the Rope Slider/Carrier Plate Assembly. Locate two Hex Head Cap Screws (H), and insert them into the outermost holes in the Rope Slider side of the Carriage Assembly. Tighten bolts. **DO NOT OVER TIGHTEN.**

Step 9 Locate the bottom half of the Metal Rope Guide (Q - Left, S - Right) for the appropriate side of the system. Position Guide with the rope in one slot and the rope sewn into the webbing of the cover into the other slot. *(Illustration represent the Right side.)*

Step 10 Slide the end the Metal Rope Guide into the center channel on the underside of the track.

Step 11 Locate the top half of the Metal Rope Guide (P - Left, R - Right) for the appropriate side of the system. Position it on the bottom half and mark the center of the hole on the track. *(Illustration represents the Right side.)*

Step 12 Remove the Metal Rope Guides and drill a hole as marked in Step 11 with a 1/4" drill bit.

Step 13 Reinsert the bottom half of the Metal Rope Guide. Position the ropes, then position the top half of the Metal Rope Guide on the bottom half. Secure the halves together with Button Head Allen Screw (P) in the hole closest to the end, and the Flat Head Allen Screw (Q) in the hole drilled through the track.

Step 6

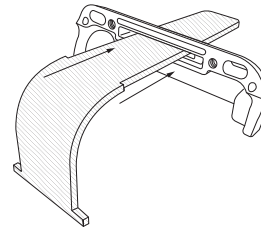

Step 7

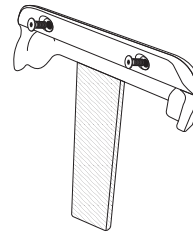

Step 8

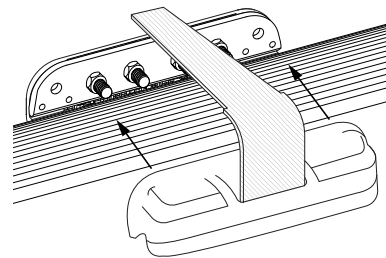

Steps 9-11

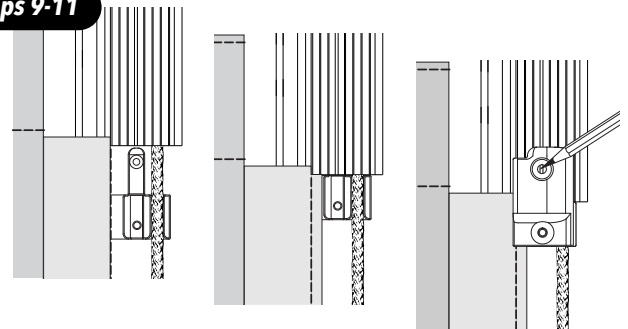

Step 13

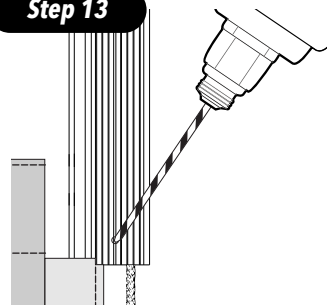

INSTRUCTIONS

Step 14 Locate two Hard Stops (N), four Oval Head Phillips Screws (F) and four #12 Anchors (L). Position one Hard Stop near the far end of the track, and the other near the cover lid. Lay the stop so the thicker end is flush with the front channel and the holes are at the center of the track.

Step 15 Mark the two hole locations. Drill 1/4" holes at each mark.

Step 16 Partially screw the Anchor onto the Oval Head Phillips Screw and tap screw through the track and into the hole 1" from the top.

Step 17 When the Anchor is set, unscrew the Oval Head Phillips Screws. Set the Hard Stop in place and secure in with the Oval Head Phillips Screw until the head is flush with the tack.

Step 18 Slide the Lead Edge onto the cover from one end toward the side with the carriage assembled.

Step 19 Insert the end of the Lead Edge Bracket into the slot in the Dowel that matches the measurement from the pool deck to the bottom of the lead edge bar.

Step 20 Repeat steps 2 - 19 (except Step 18) on the opposite side of pool.

Step 14

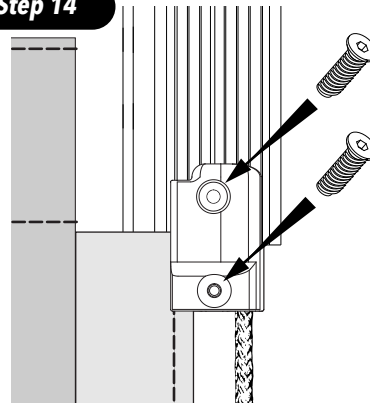

Step 15

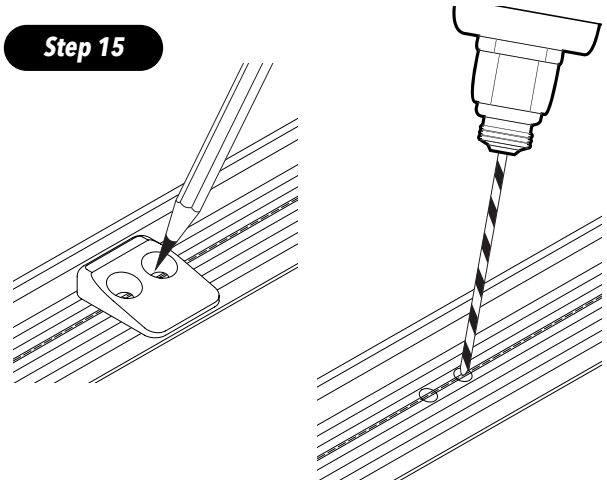

Step 16 & 17

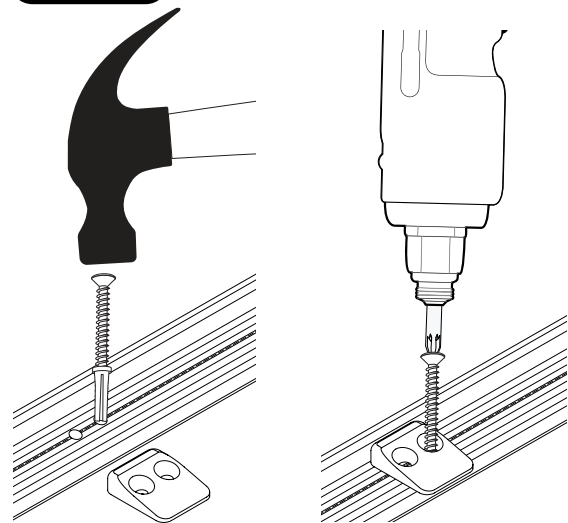

TECHNICAL SUPPORT

If you have any questions about these installation procedures, please contact Technical Support (800) 878-5789 Monday through Friday.

Automatic Pool Covers, Inc.

(800) 878-5789 • automaticpoolcovers.com

COVERSTAR SLIDER

CS-A001 & CS-A002 Installation Instructions

POSITIONING

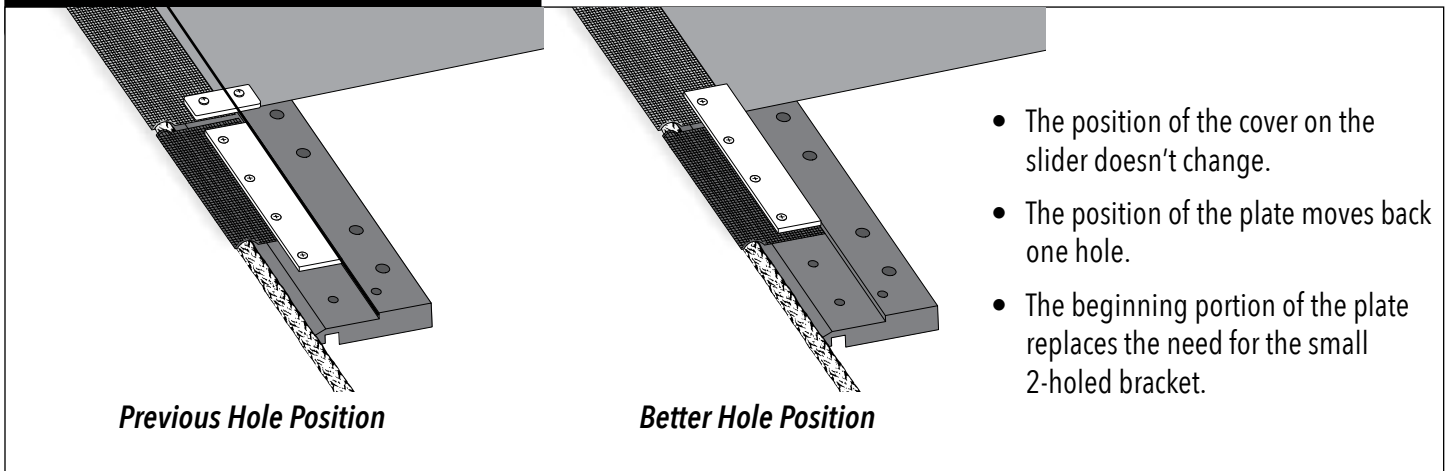

INSTRUCTIONS

1. Align the 4 holes in the tab and webbing with the first 4 holes on the slider.
2. Position holes in plate over the same holes.
3. Secure with 4 screws.

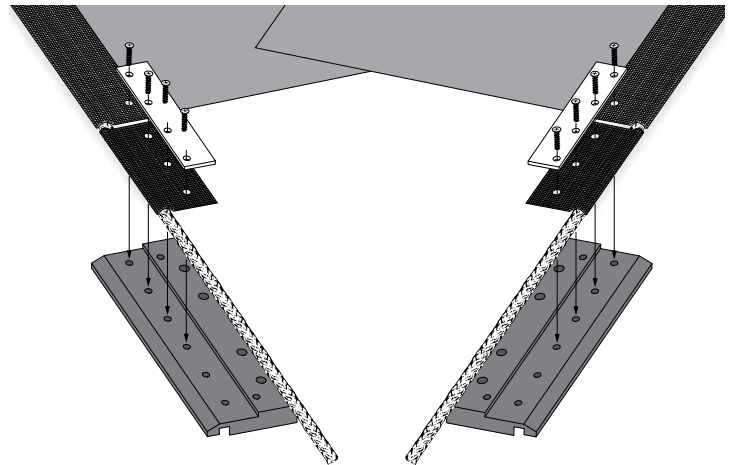

TECHNICAL SUPPORT

If you have any questions about these installation procedures, please contact Technical Support (800) 878-5789 Monday through Friday.

MOTOR CONVERSION KIT

KA-0180 Instructions

For Coverstar 4 Wire and Cantar Wet System Motors

TOOLS

1. 3/8" & 1/4" Wrench/Socket Wrench
2. 1/4" Allen Wrench

PARTS IDENTIFICATION

Part	Qty	APC #	Description
A	1	MC-0563	Gearmotor Shaft Adapter
B	2	MC-0564	Gearmotor Mounting Spacer
C	1	HC-0013	Hex Head Cap Screw (3/8-16 UNC x 1.75, 18-8 S/S)
D	1	HC-0062	Nylock Nut (3/8-16 UNC, 18-8 S/S)
E	4	HC-0020	Hex Head Cap Screw (1/4-20 UNC x .75, 18-8 S/S)
F	8	HC-0021	Split Lock Washer (1/4, 18-8 S/S)
G	4	HC-0218	Button Head Allen Screw (1/4-20 UNC x .50, 18-8 S/S)
H	2	HC-0242	Square End Key (3/16 Square x 1.00, Plain Steel)

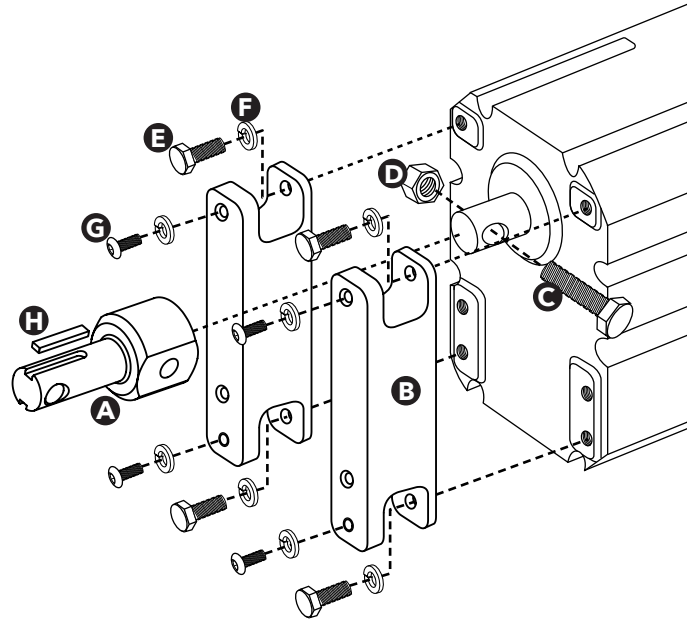

INSTRUCTIONS

1. Align the holes in the Gearmotor Shaft Adapter (A) to the holes in the motor shaft. Secure the Adapter to the motor shaft using the Hex Head Cap Screw (C) and the Nylock Nut (D).
2. Depending on the system being retrofitted, insert 1 or both Square End Keys (H) into the slot(s) in the Gearmotor Shaft Adapter. Put the Key into slot and slide it forward to lock it into place.
3. Attach a Mounting Spacer (B) to the motor base using two Hex Head Cap Screws (E) with Split Lock Washers (F). Be sure the Spacer is orientated so the thinner wall (with the unthreaded holes) faces the motor, and the 2 closer spaced, threaded holes on the opposite side are toward the bottom. Attach the second Mounting Spacer on opposite side in the same way.
4. Using the Button Head Allen Screws (G) with Split Lock Washers (F), connect the Spacers to the existing motor mounting bracket.

NOTE: When using on Coverstar Eclipse system, use existing mounting screws PHMS 1/4-20 x 5/8" S/S.

Step 4

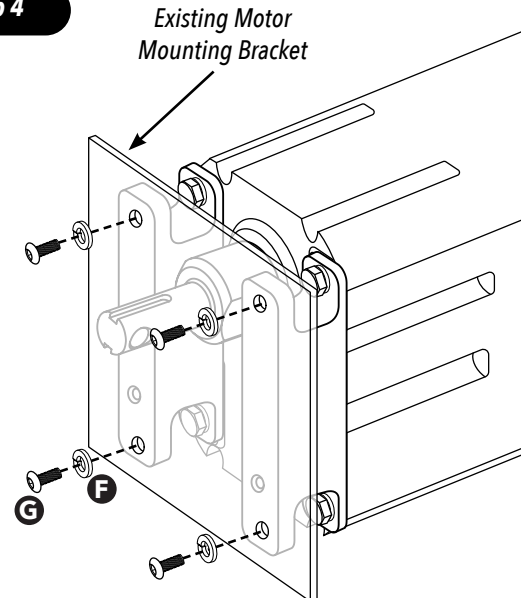

TECHNICAL SUPPORT

If you have any questions about these installation procedures, please contact Technical Support (800) 878-5789 Monday through Friday, 8 am - 5 pm EST.

MOTOR CONVERSION KIT

CPK 006 Instructions

For Cover Pools SCII or Diamond Series Motors

TOOLS NEEDED

1. 3/8" & 1/4" Wrench/socket wrench
2. Drill
3. 5/16" Drill bit

PARTS IDENTIFICATION

Part	Qty	APC #	Description
A	4	HC 0186	Studs (SHSS 1/4-20 x 1.25" cup)
B	8	HC 0004	Nuts (1/4-20 Hex 18-8 S/S)
C	4	HC 0021	Lock washer (1/4" split 18)
D	1	CP 0051	Coupler - B motor threaded
E	1	CP 0050	Coupler - A motor CP
F	2	HC 0066	Coupler Bolts (HHCS 3/8-16 x 2.00" 18-8 S/S)
G	2	HC 0014	Washer 3/8 split lock 18

INSTRUCTIONS

- Step 1** Remove Cover Pools motor off of frame.
- Step 2** Partially screw old motor bolts into template plate MC 0230 - **Sold Separately**.
- Step 3** Align and insert bolts into the frame, install template plate to frame.
- Step 4** Drill out the 4 holes for the gear box with a 5/16" drill bit.
- Step 5** Remove bolts supplied with APC motor, and install the studs (A) into the gear box of the motor.
- Step 6** Attach the nuts (B) onto the studs all the way against the gear box. This is needed for the proper shifting of the single dogs into the double dog.
- Step 7** Install the new APC motor onto the mechanism frame and attach with the 4 lock washers (C) and nuts (B).
- Step 8** Install the threaded motor coupler (D) on the bottom and use the non threaded coupler (E) on top with the 2 coupler bolts (F) and lock washers (G).

NOTE: If the clutches do not line up, you may have to remove the nuts for backing and install flat washers instead until the clutch gap is aligned properly.

TECHNICAL SUPPORT

If you have any questions about these installation procedures, please contact Technical Support (800) 878-5789 Monday through Friday.

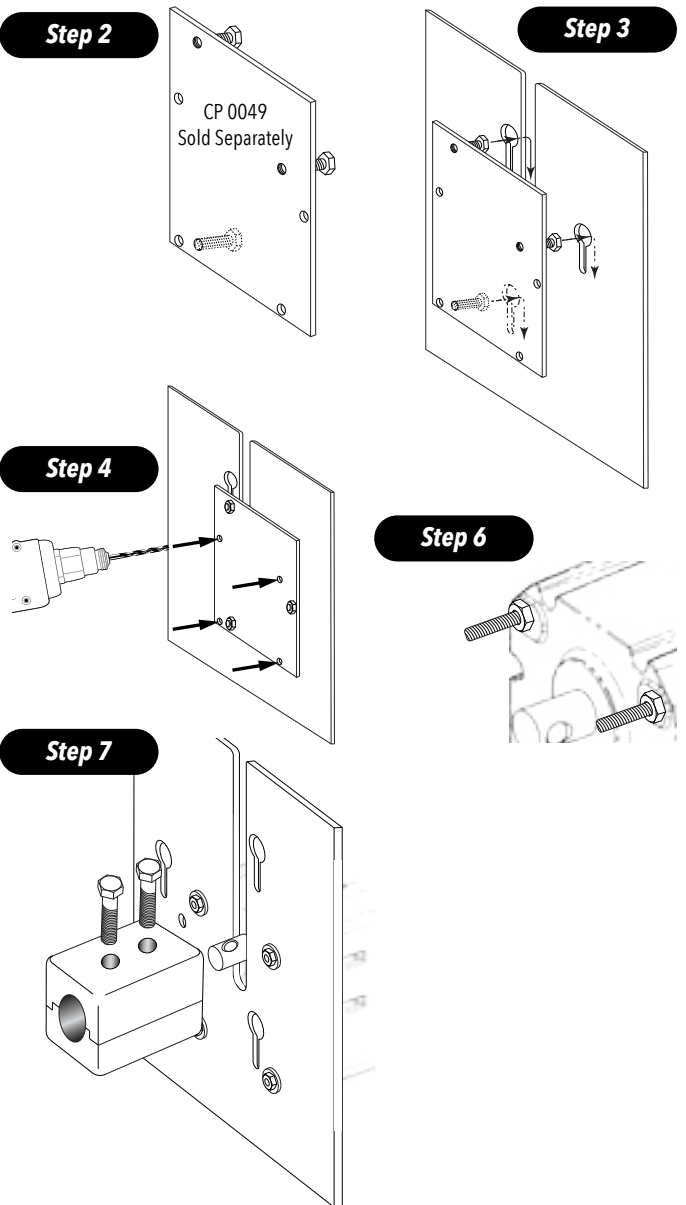
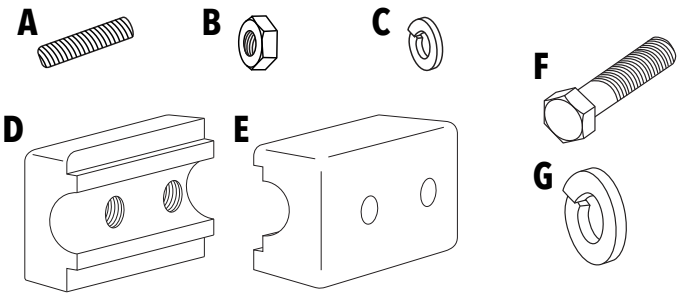

WATER FEATURE SENSOR
KA-0355 3-Channel Adapter Kit Instructions

PARTS IDENTIFICATION

Item	Qty	Part#	Description
A	1	HC-0195	Socket Head Cap Screw (#10-24 UNC x 1.50 18-8 S/S)
B	1	MC-0839	3-Channel Sensor Mounting Plate
C	1	EA-0072	Sensor Assembly w/TVS, 24 VAC/DC

INSTRUCTIONS

1. Remove closest hex head cap screw w/lock nut from existing 3-channel guide assembly (RA-0006) and discard screw.
2. Insert new socket head cap screw (HC-0195) through top hole in existing metal bracket and through clearance hole in Sensor Mounting Plate (MC-0839). Position black bracket to right side.
3. Reinstall nylock nut from standard assembly and hand tighten. **Do not overtighten.**
4. Install Sensor Assembly (EA-0072) into Sensor Mounting Plate (MC-0839) by threading body in until sensor head is flush with top side as shown above.
5. Hand tighten jam nut to Sensor Assembly to Sensor Mounting Plate (MC-0839). **Do not overtighten.**

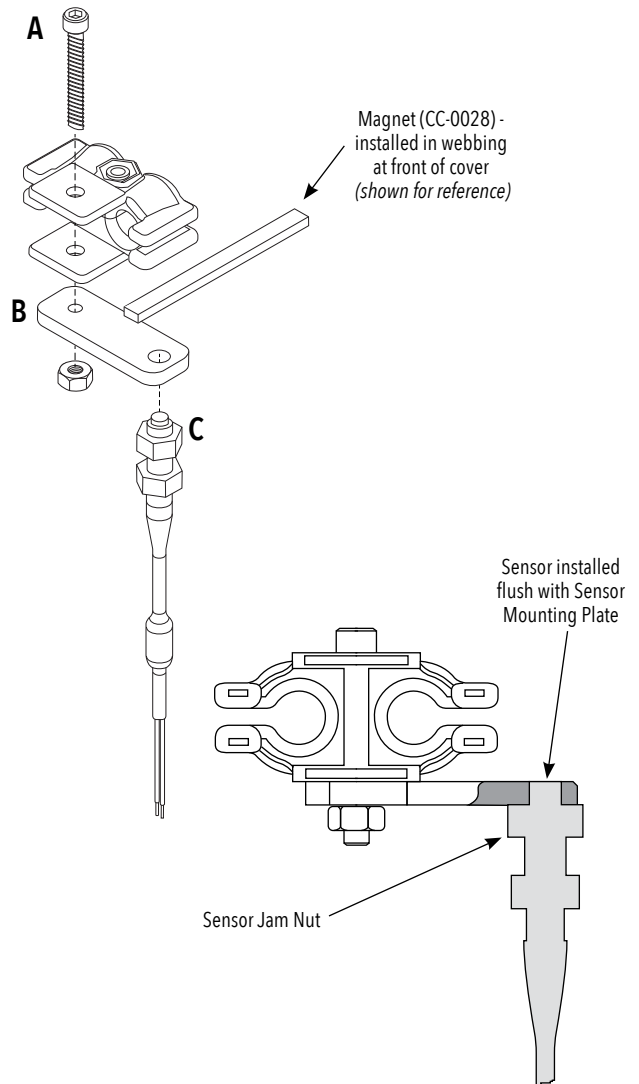

TECHNICAL SUPPORT

If you have any questions about these installation procedures, please contact Technical Support (800) 878-5789 Monday through Friday, 8 am - 5 pm EST.

TRACK/RETAINER LOCKING PIN

Installation Instructions

HARDWARE & TOOLS NEEDED

- 1. Cordless drill
- 2. 1/4" Drill bit

INSTRUCTIONS

Step 1 With a 1/4" drill bit, drill the existing hole in the Track and Retainer while making sure not to drill into the large channel of the track.

Step 2 Push locking pin in through holes.

Step 1

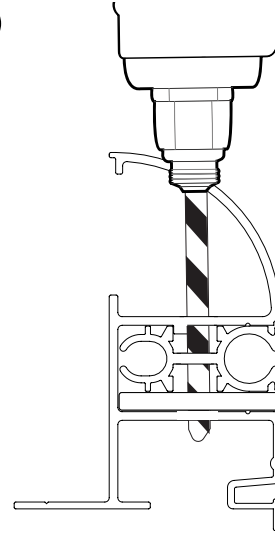

Step 2

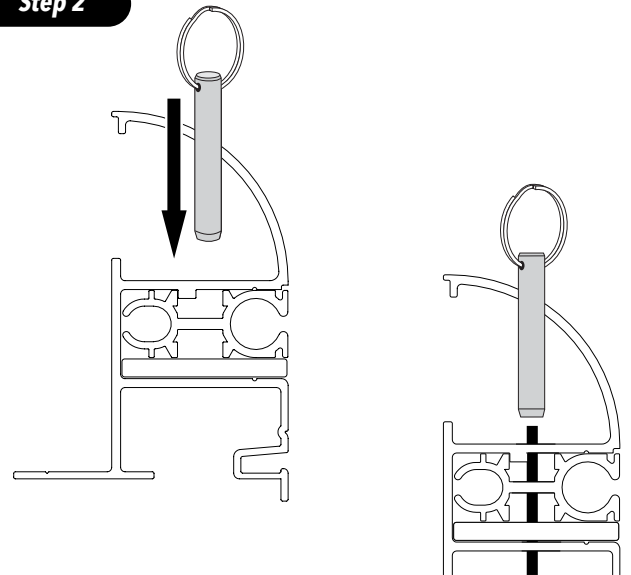

TECHNICAL SUPPORT

If you have any questions about these installation procedures, please contact Technical Support (800) 878-5789 Monday through Friday.

PATCH KIT

Patching Holes, Tears and Pinholes

INSTRUCTIONS

Note: ONLY holes less than 2 inches in diameter and ONLY tears less than 3 inches in length should be patched by the homeowner. Larger non-conformances in the cover should be evaluated by an automatic pool cover professional.

1. Patching Holes and Tears

Step 1.1 Move cover so area to be patched is resting on your deck surface instead of the water.

Step 1.2 Clean the area of pool cover around hole with a wet cloth before patching. Be sure area is dry.

Step 1.3 Cut an appropriate size round/oval patch. Make sure there are no square corners. Rounded edges will help keep the patch from catching and pulling up.

Step 1.4 Place the patch over the tear and outline the patch with a pencil. (Patch shown in darker color for illustration purposes only.)

Step 1.5 Apply HH-66 vinyl cement to the "rough" side of the patch and on top of the pool cover in affected area inside of the outline.

Step 1.6 Allow time for adhesive to become slightly tacky on patch and on pool cover.

Step 1.7 Press patch on damaged area for approximately 3 minutes (keep smooth side of vinyl on top.)

Step 1.8 Allow to dry before operating cover.

2. Patching Pinholes

Step 2.1 Move cover so pinhole area to be patched is resting on your deck surface instead of the water.

Step 2.2 Clean the area of pool cover around hole with a wet cloth before patching. Be sure area is dry.

Step 2.3 Apply HH-66 vinyl cement directly to the pin hole.

Step 2.4 Allow to dry before operating cover.

Step 1.2

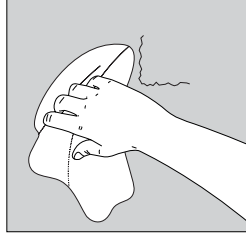

Step 1.3

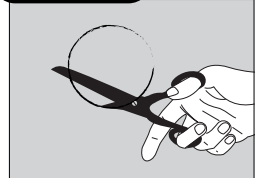

Step 1.4

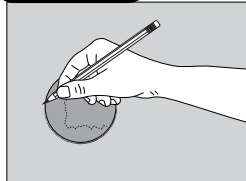

Step 1.5



Step 1.7

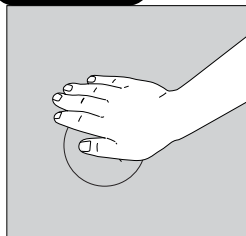

Step 2.2

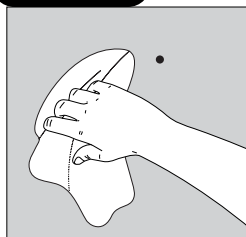

Step 2.3



TECHNICAL SUPPORT

If you have any questions about these installation procedures, please contact Technical Support (800) 878-5789 Monday through Friday.

ATLAS BRACKET
Heavy Duty Lide Bracket (MA-0165)

INSTRUCTIONS

1. Remove locking clevis pin and arm
2. Determin mounting location and drill pilot holes. Install mounting hardware.
3. Place arm in base and insert locking clevis pin.
4. Level backet by turning the adjustment bolt. Rotate clockwise to raise the arm, rotate counter-clockwise to lower the arm.
5. If equipped with an extention arm, set appropriate length and install and tighten the bolt.

HINT: To ensure the bracket won't slide down if the upper wedges become loose over time, insert wedges in the upper-most part of the bottom set of slots on the bracket.

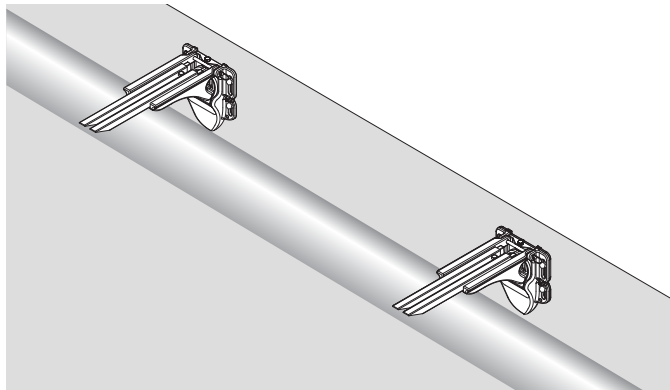

Step 1

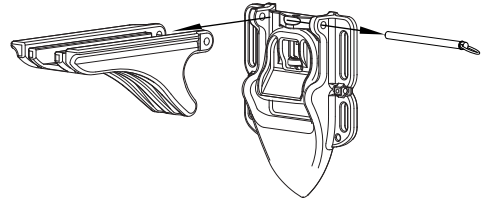

Step 2

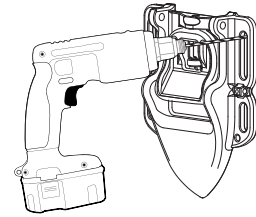

Step 3

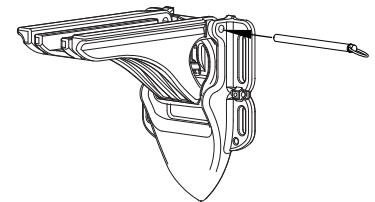

Step 4

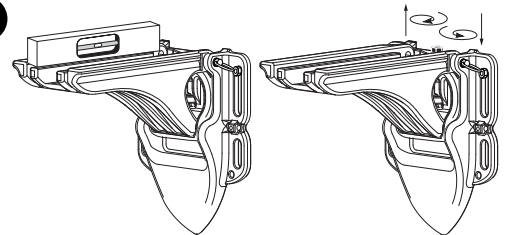

Step 5

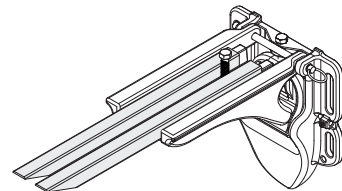

Hint

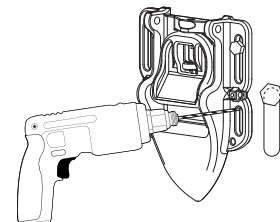

TECHNICAL SUPPORT

If you have any questions about these installation procedures, please contact Technical Support (800) 878-5789 Monday through Friday, 8 am - 5 pm EST.

FLUSH LID LOCK KIT

KA 0353 Instructions

PARTS IDENTIFICATION

Item	Qty	Part#	Description
A	2	HC 0184	#8 x 12 TEK screws
B	1	MC 0771	Bracket Lock 365 1 piece Lid End R
C	2	MC 0772	Bracket Lock 365 1 piece Lid Seam Support

TOOLS REQUIRED

1. 5/32" Drill Bit
2. 7/16" Socket
3. 1/4" Hex drive
4. 7/16" Open ended wrench

INSTRUCTIONS

1. Mount Bracket Lock Lid End to tab on Riser End Plate from below and secure with TEK screws (A)
2. Slide end of lid onto the End Lid Bracket.
3. Assemble the 365 Lid Seam Support Brackets with 2 Bracket Lock Seam Support (C) between the two halves while the Lid Seam Brackets are in the Riser.
4. Slide ends of lids onto the Brackets with the tabs in the second slot from either end.

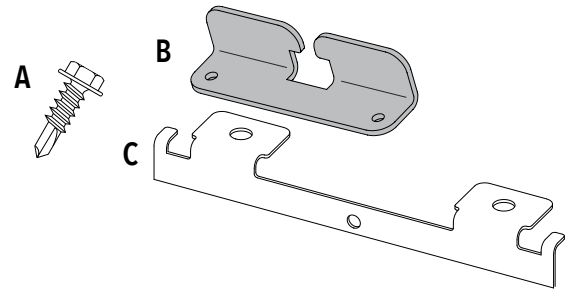

Step 1

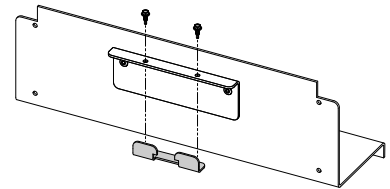

Step 2

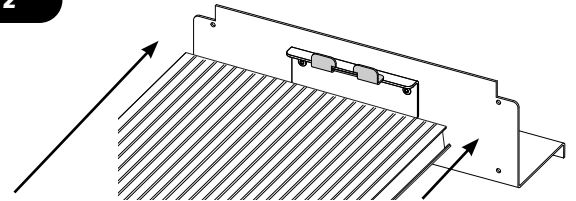

Step 3

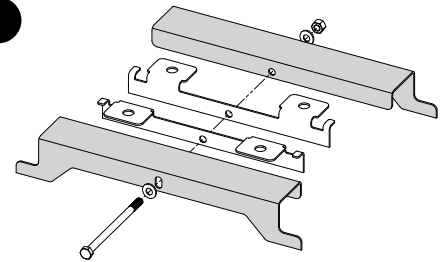

Step 4

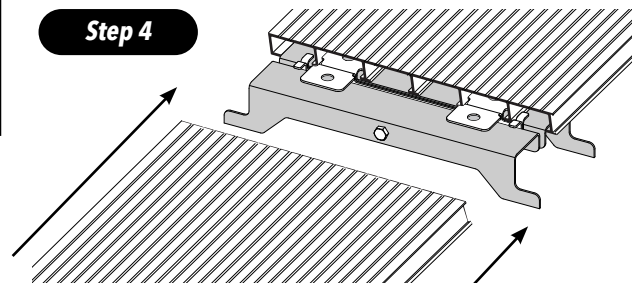

TECHNICAL SUPPORT

If you have any questions about these installation procedures, please contact Technical Support (800) 878-5789 Monday through Friday, 8 am - 5 pm EST.

FLUSH LID SEAM SPLICE
MA 0259 Instructions

PARTS IDENTIFICATION

Item	Qty	Part#	Description
A	2	MC 0783	Lid Seam Splice

INSTRUCTIONS

IMPORTANT: If splicing lid sections that have been cut, be sure the ends are filed to remove any burrs or shavings.

- Step 1** Slide a Splice half way into the second slot from either side of one of the lid sections to be spliced.
- Step 2** Align second lid section and slide onto splice.
- Step 3** Splice should rest evenly between lid splices.

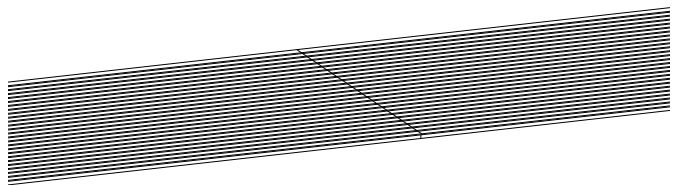
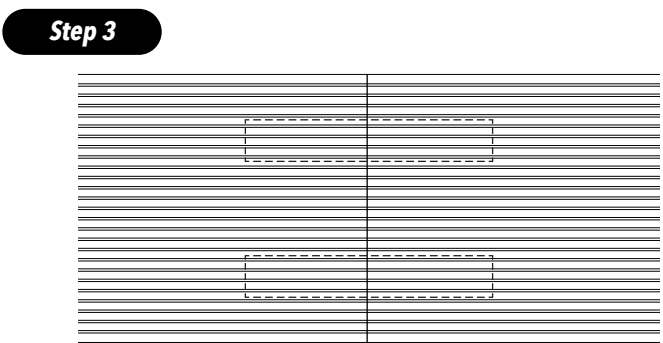
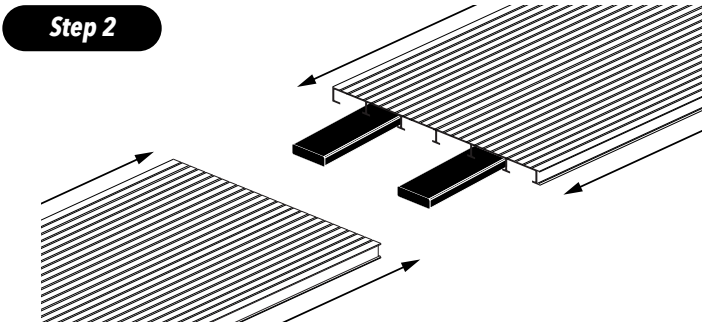
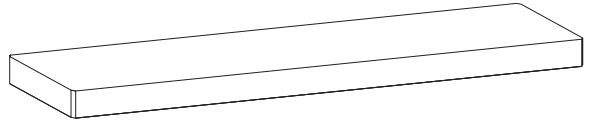

TECHNICAL SUPPORT

If you have any questions about these installation procedures, please contact Technical Support (800) 878-5789 Monday through Friday, 8 am - 5 pm EST.

TOOLS REQUIRED

For use with vinyl liner systems using concrete or stone lids

1. 7/32" Allen Wrench
2. 9/16" Socket

INSTRUCTIONS

1. Install Channel Plates: (A) Tilt Channel Plate back and insert up into the polymer box rail. (B) Slide Channel Plate up to the top of the channel. (C) Let Channel Plate rest in place.
2. Align the plate so the Counter Sunk holes on the back side of the plate line up with the oblong holes on the base.
3. Attach the Mounting Plate to the Base with the Taper Head Screws and Bolts.
4. Align assembly with channel plate in polymer box rail. Adjust height and when proper height is set, tighten the bolts.
5. Secure assembly to the Channel Plate with bolts through the 3 holds on the top of the Mounting Plate.
6. Continue to assemble bracket following the instructions included with the bracket.

Step 1

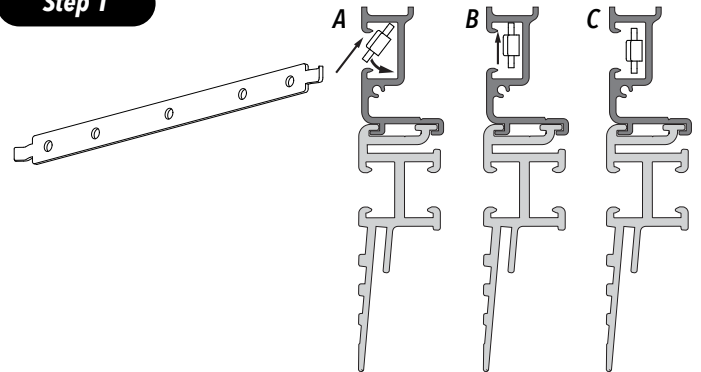

Step 2

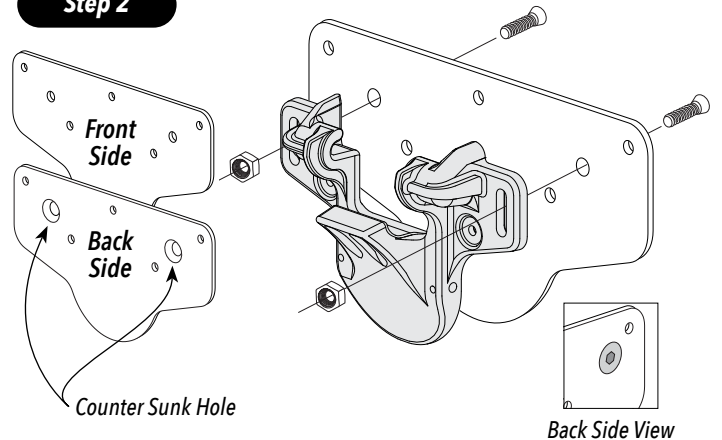

Step 5

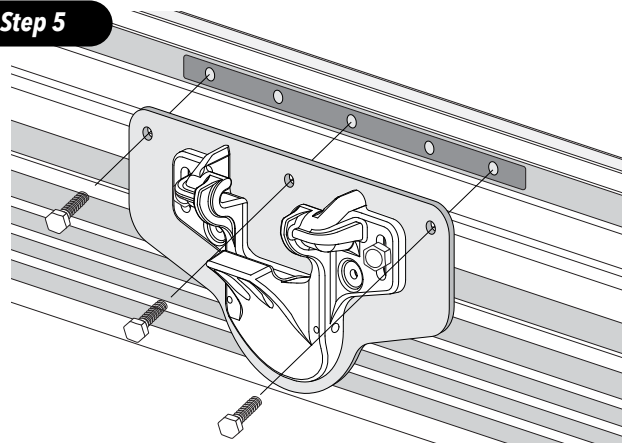

TECHNICAL SUPPORT

If you have any questions about these installation procedures, please contact Technical Support (800) 878-5789 Monday through Friday, 8 am - 5 pm EST.

SYMPTOM	POSSIBLE PROBLEM	SOLUTION
Cover will not move - no sound	No power to unit	<ol style="list-style-type: none"> 1. Reset circuit breaker or outlet 2. Check for secondary power switch 3. Plug in the power cord
Cover will not move	Motor makes loud grinding noise	<ol style="list-style-type: none"> 1. Replace motor gears
Cover will not move	Motor shaft spinning - unit not moving	<ol style="list-style-type: none"> 1. Torque limiter needs to be adjusted 2. Ropes are pinched, obstructed or broken 3. Clutches are not engaging-clutches need to be moved together 4. Motor coupler bolts are broken and need to be replaced 5. Check end casting for stripped out screws 6. Replace drive pin 7. Cover is backed out of track - reinstall cover into track 8. Too much water on the cover - remove excess water
Cover opens uneven	Ropes are uneven	<ol style="list-style-type: none"> 1. Open cover and re-pin the ropes equally on rope reel
	Tube is not centered	<ol style="list-style-type: none"> 1. Center the tube between the tracks
	Cover has rolled up an object	<ol style="list-style-type: none"> 1. Close cover and remove object
Cover closes uneven	Ropes are uneven	<ol style="list-style-type: none"> 1. Align pulleys to feed ropes in the center of the rope reel
	Ropes stack unevenly on the rope reels	<ol style="list-style-type: none"> 1. Add diameter to the slow closing rope reel
Cover has water build-up on top	Rain water needs to be removed	<ol style="list-style-type: none"> 1. Pump water off with a cover pump
	Cover has hole(s) in fabric	<ol style="list-style-type: none"> 1. Patch the holes with patch kit
Cover is running rough "jerking" or "catching"	Cover is catching at the track splice	<ol style="list-style-type: none"> 1. Close the gap between the track
	The recess box is full of debris	<ol style="list-style-type: none"> 1. Remove debris from cover box
	The cover is near the end its life	<ol style="list-style-type: none"> 1. Replace cover 2. Raise the water level just below the top of the skimmer
	The pulleys are locked up	<ol style="list-style-type: none"> 1. Replace all locked pulleys
	The webbing is catching on the guide	<ol style="list-style-type: none"> 1. Repair the webbing 2. Remove the cover and replace the webbing 3. Replace the cover
	The cover is sticking to the deck	<ol style="list-style-type: none"> 1. Billow the cover by lifting the vinyl using a leaf blower 2. Add a suction break (e.g. carpet) under the cover
	The rope reel tension is too tight	<ol style="list-style-type: none"> 1. Loosen the nylon block bolts 2. Remove rope reel and remove corrosion within
	Debris in the track	<ol style="list-style-type: none"> 1. Spray the debris out of the track with water or air
	Gliders are broken	<ol style="list-style-type: none"> 1. Replace glider bodies
Cover pump does not work properly	No power to the pump	<ol style="list-style-type: none"> 1. Reset the circuit breaker or outlet; check that pump is plugged in 2. Check for secondary power switch 3. Replace the cover pump
	Pump does not turn on or off	<ol style="list-style-type: none"> 1. Check manufacturer's instruction/plug-in procedures 2. Check hose connection and/or for blockage 3. Remove debris build up from pump base 4. Replace the cover pump

For further assistance, please contact Technical Support (800) 878-5789

TOOLS NEEDED

- | | | | |
|---------------------|------------------------------------|----------------------------|-----------------------|
| 1. Cordless drill | 2. 12" Torpedo level | 3. 1/2" Round bastard file | 4. Hammer |
| 5. 25' & 100' tapes | 6. 100' string | 7. Box knife | 8. Drill bits: 11/64" |
| 9. Chop saw | 10. Wrenches/sockets: 7/16", 9/16" | | |

STEP 1: LAYING OUT COPING & RETAINER (VLR)

INSTRUCTIONS

A standard coping system consists of:

- 2 prefabricated opposite end corners (coping only)
- 2 prefabricated mechanism end corners (coping and wall cap)
- Several pieces of straight coping (depending on pool size)
- Coping clips

- 1.1 Place each opposite end corner piece in a corner at the opposite end of the pool. Ensure the bead receiver lip is against the inside surface of the wall.
- 1.2 Fasten both corners to the wall flange with TEK screws, beginning 1" from each end, and approximately every 16"-18" between.
- 1.3 Place each mechanism end corner piece in a corner at the mechanism end of the pool. Again, ensure bead receiver lip is against the inside surface of the wall.
- 1.4 Fasten both corners to the wall flange with TEK screws, beginning 1" from each end, and approximately every 16"-18" between.

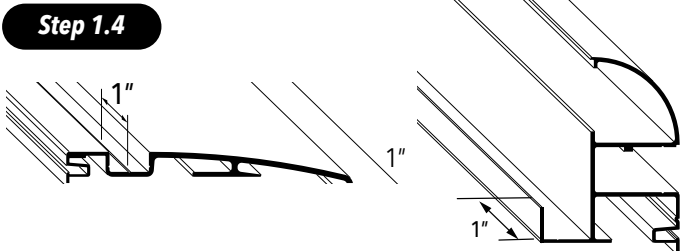
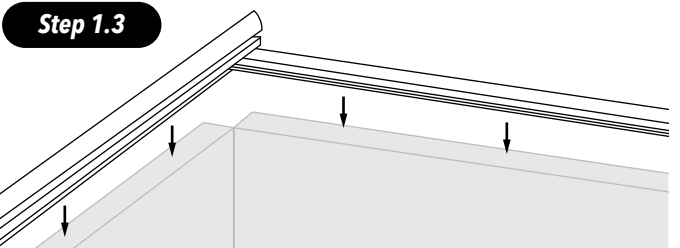
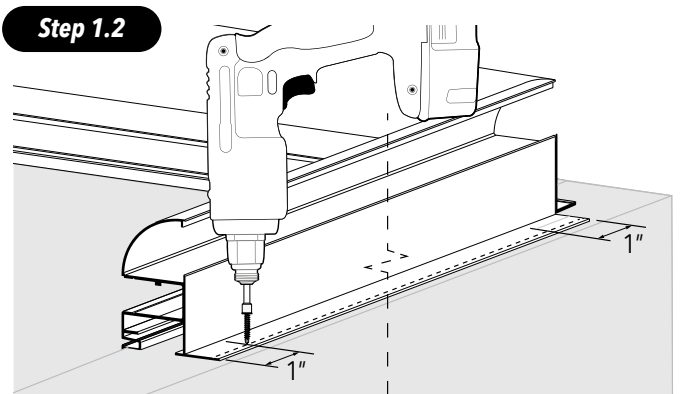
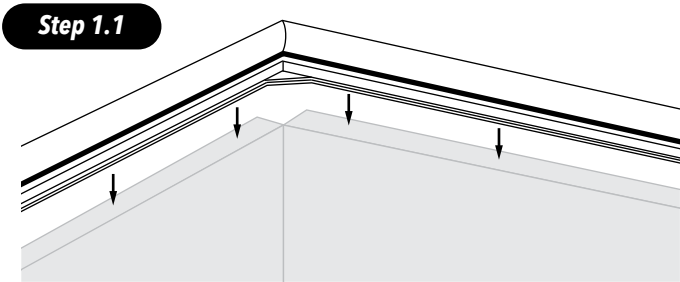

INSTRUCTIONS (CONTINUED)

- 1.5 With the corners secured, place straight pieces of coping in the gaps between the corners. Measure and cut each piece as necessary to achieve even lengths. Fasten each piece with TEK screws starting 1" from each end, and every 16"-18" between.
- 1.6 Install clips wherever two pieces of coping meet. Hook the clip on the back of the coping, evenly straddling the splice, and push down until it clicks, and lies flat on the coping.
- 1.7 Measure the gap left between the mechanism end corners and cut straight piece of wall cap to fit. Fasten wall cap to wall flange with TEK screws starting 1" from each end, and every 16"-18" between.

Step 1.5

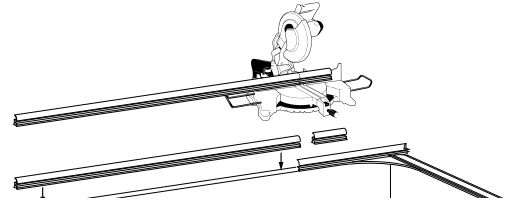

Step 1.6

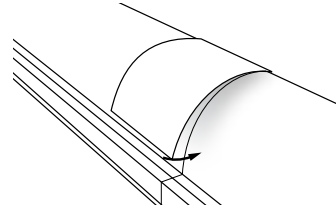

Step 1.7

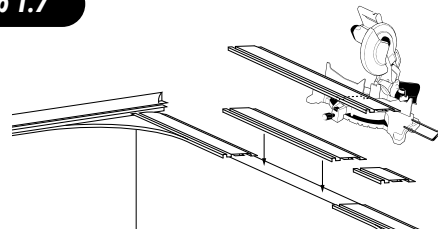

STEP 2: POLYMER BOX INSTALLATION

INSTRUCTIONS

The polymer box system consists of:

- 1 box section with a pre installed box end
 - Several more box sections (depending on width of pool)
 - Box support brackets and hardware
 - 1 box end
- 2.1 Install steel box support brackets to the side of wall seams no higher than 14.25" using supplied hardware.
 - 2.2 Locate box section with pre installed box end. Align mark on section with interior edge of coping on whichever side is intended to house motor (left or right.)
 - 2.3 Slide polymer box onto lip of wall cap. Maintain the same spacing, from side to side, between the polymer box rail and wall cap.

Step 2.1

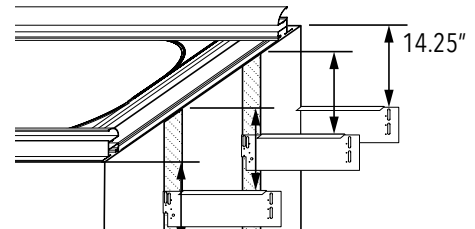

Step 2.2

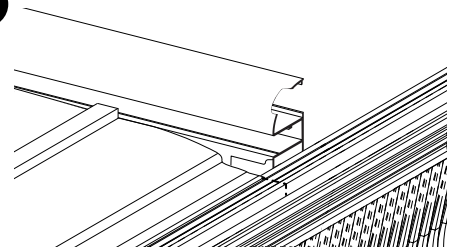

Step 2.3

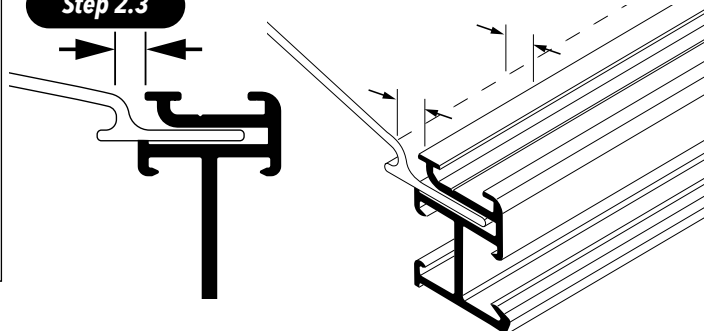

INSTRUCTIONS (CONTINUED)

- 2.4 Starting 1" from end, drill a pilot hole through aluminum box rail and wall cap. Fasten with TEK screw. Repeat at other end, and space fasteners every 16"-18" between. For best results drill pilot hole at angle shown.
- 2.5 Slide box splice pieces into channels inside box rails as shown.
- 2.6 Slide next box section onto wall cap. Align with previous piece and position splices. Drill pilot holes and fasten to wall cap with TEK screws 1" from each end and every 16"-18" between.

Note: Each section nests into the flared end of the piece before it.

- 2.7 After last box section is installed, fastened, and spliced, install spring nut into back side of box rail above each box support bracket. Attach vertical support to box and to box support bracket below. Level box and tighten support hardware.

Step 2.4

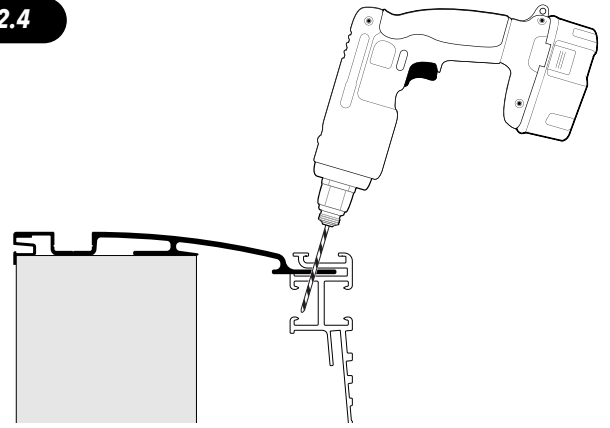

Step 2.5

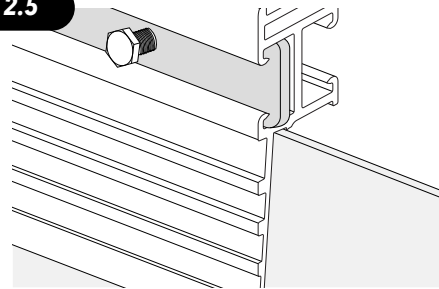

Step 2.6

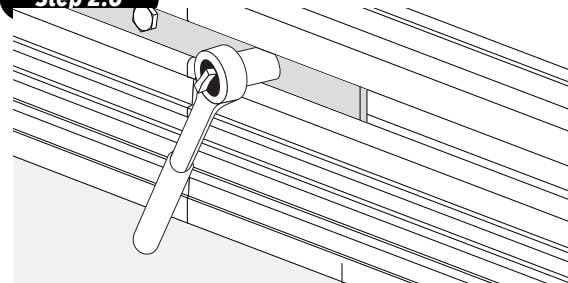

Step 2.7

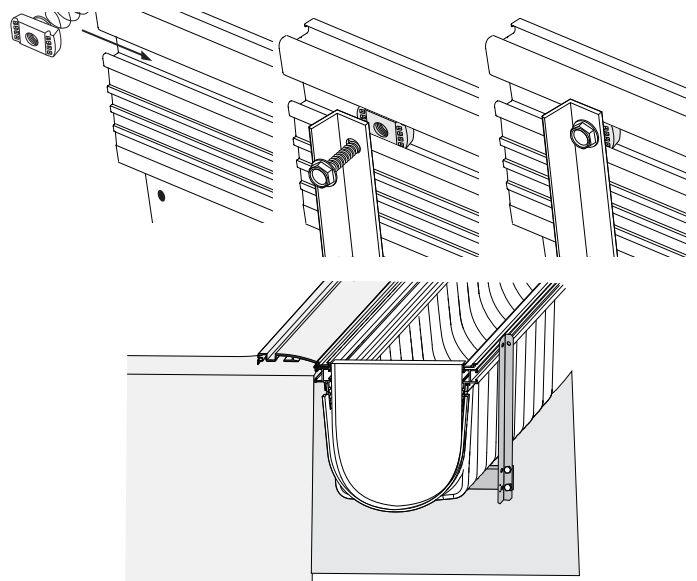

STEP 3a: STANDARD RISER w/RFC EXTENSION

INSTRUCTIONS

IF NOT USING Reusable form coping (RFC) or Lid Riser (SLR) systems, PROCEED TO STEP 3.b

3a.1 Install supplied end plates to the RFC or SLR and fasten to both riser and retainer.

Note: If using Stone Lid Riser (SLR), proceed to step 3b.1

3a.2 Cut a 32" riser extension for the motor side and secure to the top of the polymer box using 1/2" TEK Screws.

3a.3 Cut a 8" riser extension for the opposite side and secure to the top of the polymer box using 1/2" TEK Screws.

3a.4 Attach the remaining riser extension across the back of the polymer box using 1/2" TEK Screws.

3a.5 Proceed to Step 3b.

Note: TEK screws are intended only to hold riser in place. When installed along line on base of riser, it should not penetrate the rail.

Step 3a.1

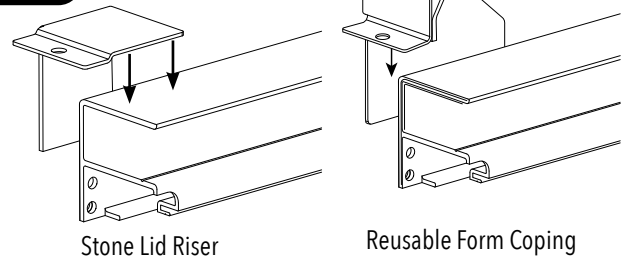

Stone Lid Riser

Reusable Form Coping

Step 3a.2 & 3a.3

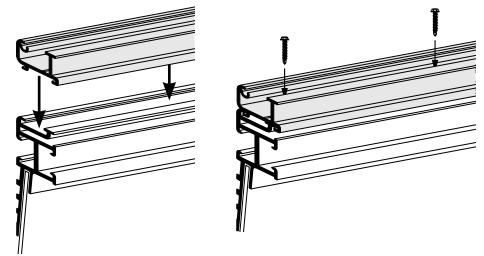

Step 3a.4

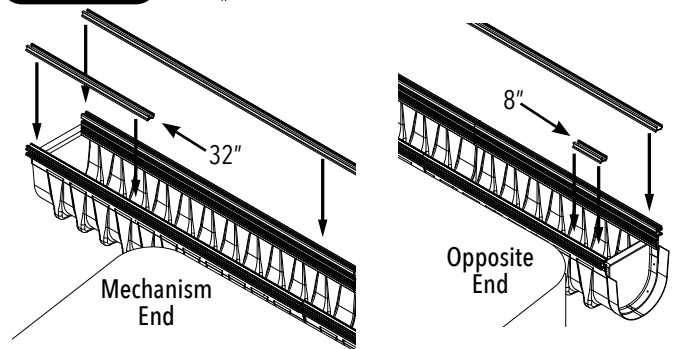

STEP 3b: STANDARD RISER INSTALLATION

INSTRUCTIONS

The Riser System consists of:

- Mechanism End Riser (3')
- Opposite End Riser (1')
- Straight Pieces
- 2 Riser End Plates

3b.1 Place 2'8" riser on the front side of the polymer box on the mechanism end. Riser will nest into aluminum top rail of box as shown. Place 8' riser in same manner at opposite end.

3b.2 Fasten to outside of coping with 1" TEK screws. TEK screws will go through pre-drilled holes in outside of coping into channels in riser. Repeat with opposite end riser.

Step 3b.1

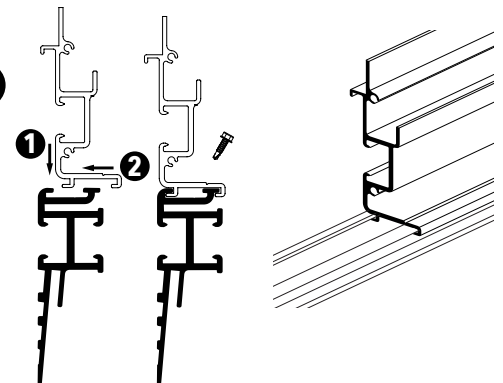

Step 3b.2

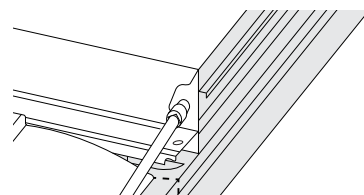

INSTRUCTIONS (CONTINUED)

3b.3 Fasten riser in place with 1/2" TEK screws 1" from both ends and 16"-18" between.

Note: TEK screws are intended only to hold riser in place. When installed along line on base of riser, it should not penetrate the rail. Repeat with opposite end riser.

3b.4 Fasten riser end plate to mechanism end riser piece through pre-drilled holes in plate and into channels in riser.

3b.5 Place full length piece of riser on top of aluminum rail on back side of box so that riser end plate forms 90° to both front and back riser sections. Fasten in place with 1/2" TEK screws 1" from both ends and every 16"-18" between.

3b.6 Fasten remaining riser end plate to 8" riser piece on front of box at opposite end. Ensuring 90° angles, measure, cut and place the last piece of riser on back side of box. Fasten with 1/2" TEK screws.

Step 3b.3

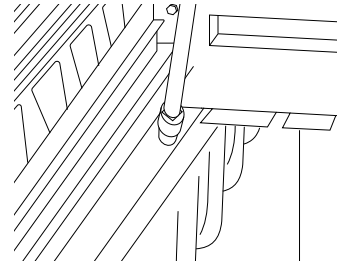

Step 3b.4

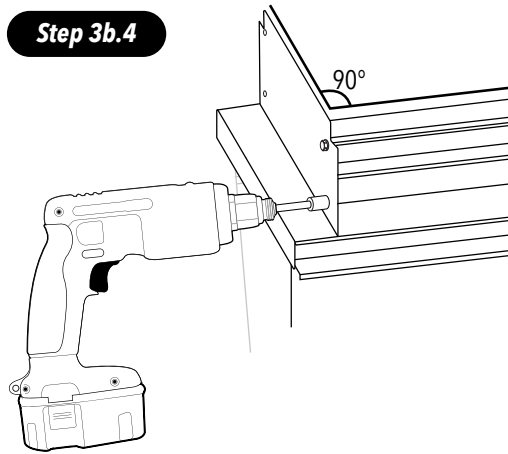

Step 3b.5

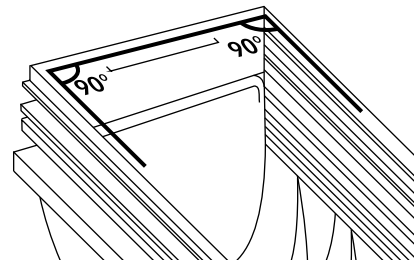

Step 3b.6

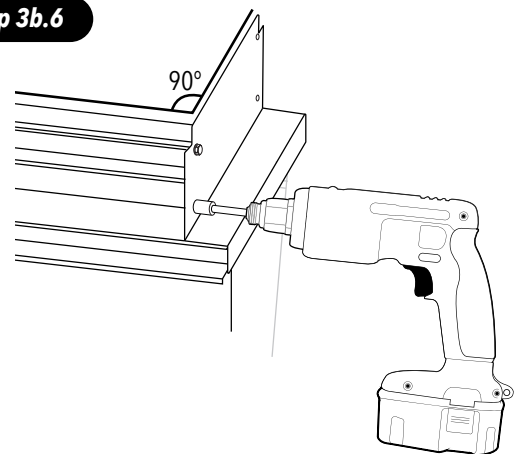

STEP 4: REUSABLE FORM COPING

INSTRUCTIONS

IF NOT USING RFC, PROCEED TO STEP 5

This section will cover the basic installation of a reusable concrete form system for use with THREE•SIXTY•FIVE applications. Including, forms, shims, locking splices, locking corner brackets, as well as the end plates that will bridge between forms and the riser.

Each section of the forms locks into the retainer and is held in place with shims.

4.1 Corners

Locate the mitered corner pieces of form and place locking splices in each piece. Place form with splices into retainer and secure with shims.

4.2 Sides

With corners assembled, fill in the remaining lengths of retainer with reusable forms. Secure each butt joint with a shim underneath and a locking splice in the front channel. Trim forms to match retainer lengths exactly.

Note: Use a chop saw if any cuts are necessary.

Step 4.1

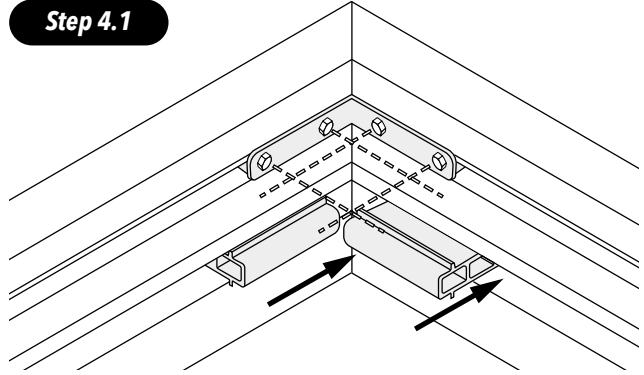

Step 4.2

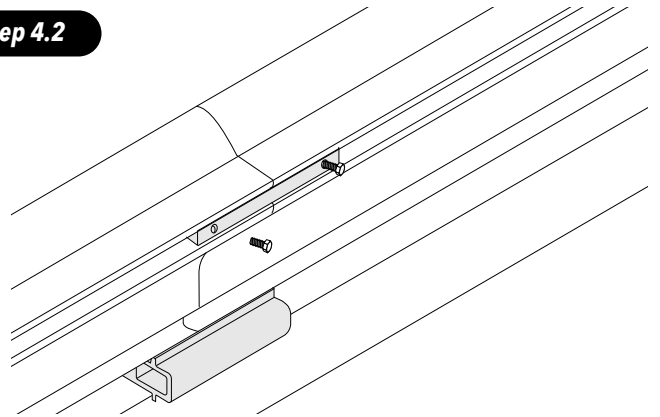

STEP 5: LID INSTALLATION

INSTRUCTIONS

The lid system consists of:

- Lid brackets
- Lid
- Lid end

5.1 Install lid brackets in riser on back side of box, evenly spaced within the track width.

Tip: Placing one bracket across the butt joint of the riser pieces will help keep pieces firmly aligned.

5.2 Level all lid brackets.

5.3 To ensure the polymer box keeps its form while the concrete is poured, insert the box supports in the top rails of the polymer box. Insert 2 box supports in each section of polymer box.

5.4 Place lid in riser as shown.

IMPORTANT: Do not cut lid

5.5 Measure remaining space for lid end and trim accordingly. Install lid end.

Tip To help keep the risers properly spaced while the concrete is poured, turnbuckles (MZ0009) are available. These will help increase or decrease the space between the front and the back of the riser and ensure the lid fits properly.

5.6 Check to make sure the box is properly leveled.

Step 5.1

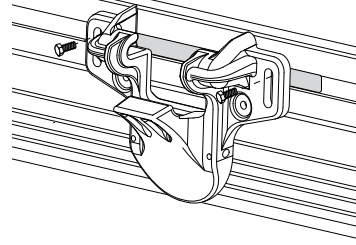

Keep a 1/8" gap from top of the base to lip of the riser.

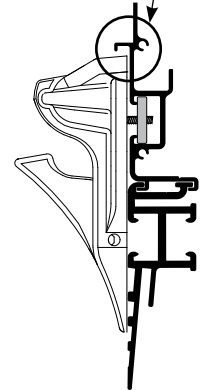

Step 5.2

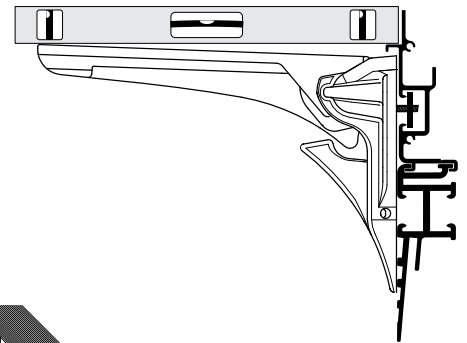

Step 5.3

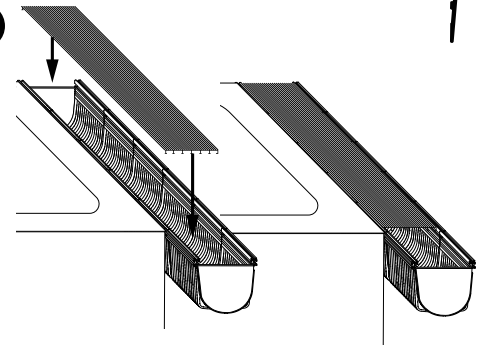

Step 5.4

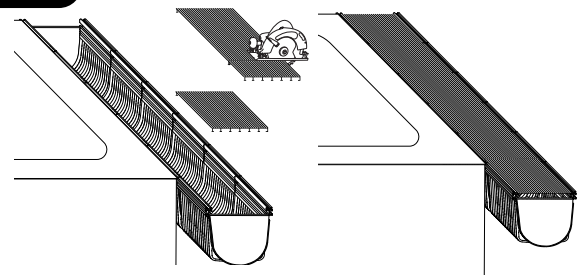

TECHNICAL SUPPORT

If you have any questions about these installation procedures, please contact Technical Support (800) 878-5789 Monday through Friday, 8 am - 5 pm EST.

Automatic Pool Covers, Inc.

(800) 878-5789 • automaticpoolcovers.com

THREE • SIXTY • FIVE Post-Pour Installation Instructions

MECHANISM

MOTOR SIDE: LEFT

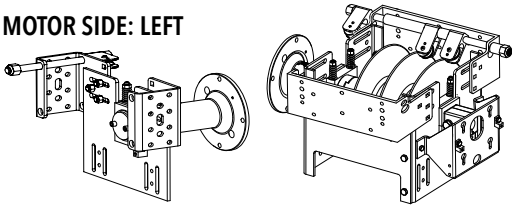

OPPOSITE END - LEFT
MA0061

MOTOR END - LEFT
MA0059

MOTOR SIDE: RIGHT

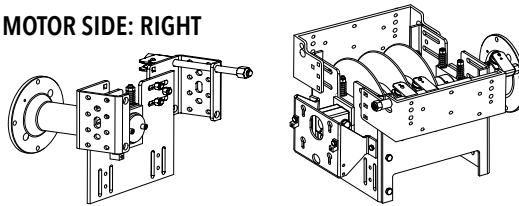

MOTOR END - RIGHT
MA0062

OPPOSITE END - RIGHT
MA0060

CONTROLLER

PowerTouch™ Key Pad

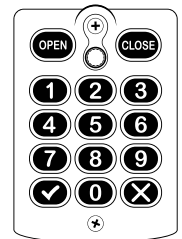

KA0287

CHANNEL PLATE

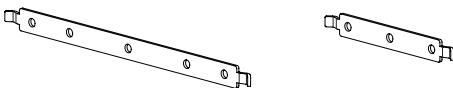

Mechanism End - MC0346 Opposite End - MC0347

DROP IN BRACKET

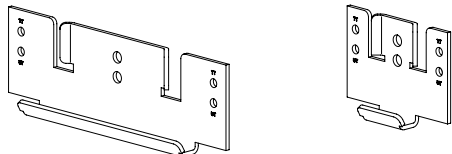

Mechanism End - MC0314 Opposite End - MC0315

PULLEY SPACER FILLER

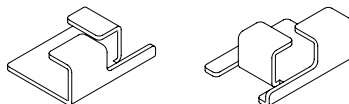

Left - MC0392 Right - MC0393

PULLEY

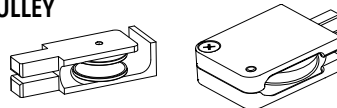

2 Channel
MC0392 3 Channel
CSA005

UNIVERSAL TRACK WEDGE

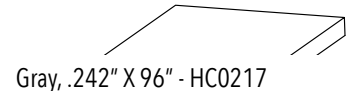

Gray, .242" X 96" - HC0217

RETAINER LOCKING PIN

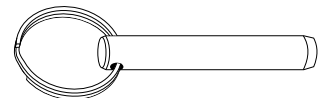

MC0922

LID FACIA

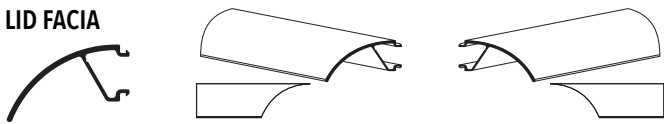

9'-0" - XC1054

Left - MC0349

Right - MC0349

LEAD EDGE with bumper

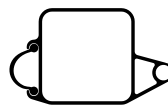

MA0131 - 15"-5"
MC0132 - 17"-5"
MC0133 - 19"-5"
MC0134 - 25"-0"

ADJUSTABLE LEAD EDGE DOWEL

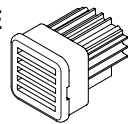

MC0352

LID SEAM SUPPORT BRACKET - KA0355



Motor End Bracket
MC0772

Opposite End Bracket
MC0771

LID LOCK - KA0286

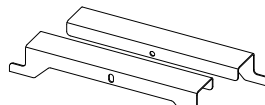

Lid Seam Bracket
MC0359

GLIDER BRACKETS - MA0249

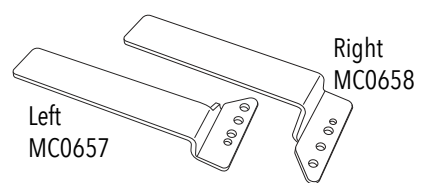

Left
MC0657

Right
MC0658

1/2" TEK SCREW



HC0184 - #8

5" BOLT

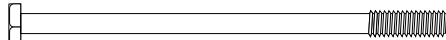

HC0267 - 5/16-18 x 5.00"

5/16" NUT



HC0002

5/16" WASHER



HC0092

3/4" BOLT



HC0174 - 3/8-16

1/2" SCREW



HC0038 - #10

SNAP CAP



HC0194

TOOLS NEEDED

- | | | | |
|----------------------------|---------------------|-------------------|--|
| 1. Socket wrenches | 2. Utility knife | 3. Cordless drill | 4. Combo wrenches: 1/2", 9/16" |
| 5. Hacksaw | 6. #2 Phillips bit | 7. Rubber mallet | 8. Drill bits: 1/4", 3/16", 11/64" |
| 9. Circular saw (optional) | 10. Scissors | 11. Lighter | 12. Allen wrenches: 3/16", 5/32", 1/8" |
| 13. Half round file | 14. Electrical tape | | |

STEP 1: MECHANISM ASSEMBLY

INSTRUCTIONS

Step 1.1 Attach Opposite End Casting to Tube using 5/16" x 3/4" bolt and lock washer.

Step 1.2 Slide nylon bearing into Opposite End bracket. Be sure the adjustment nuts are pointing upward.

Step 1.3 Attach tube to Motor Side pedestal using 5/16" x 3/4" bolt and lock washer.

Step 1.4 Install Channel Plates (Mechanism End - MC0346, Opposite End - MC0347), found in kit KA-0326, for mechanism and opposite end brackets. (A) Tilt Channel Plate back and insert up into the bracket. (B) Slide bracket up to the top of the channel. (C) Let Channel Plate rest in place.

Step 1.5 Install Drop In Brackets, found in kit KA-0326, on the Mechanism End and Opposite End with Bolts found in kit KA-0122. Install bolts into the "UT" (Under Track) holes of the bracket. Leave bolts loose to allow for adjustment after next step.

IMPORTANT: Be sure the bolts are in the "UT" holes of the bracket. The "TT" holes are for Top Track system installations only.

Step 1.6 Lower the assembled mechanism onto drop-in brackets. Ensure each mounting bracket is straddling the proper drop-in bracket and loosely fasten mounting bracket to channel plate through drop-in bracket with Bolts.

Step 1.7 Align assembled unit side to side as illustrated. When properly aligned, tighten all bolts.

Step 1.1

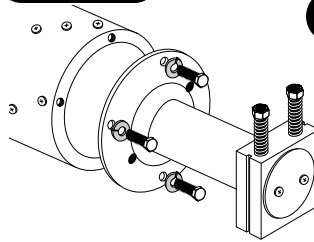

Step 1.2

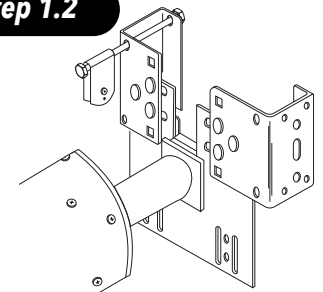

Step 1.4

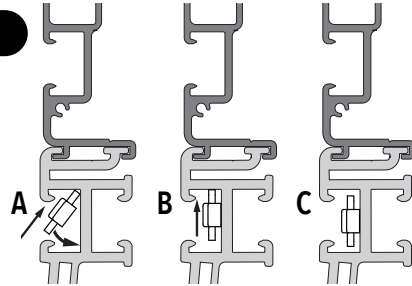

Step 1.5

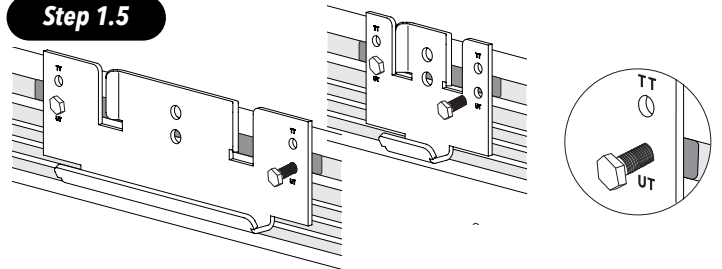

Step 1.6

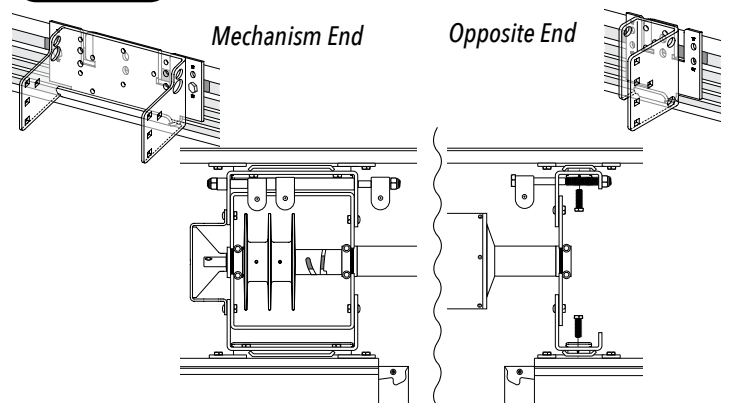

Step 1.7

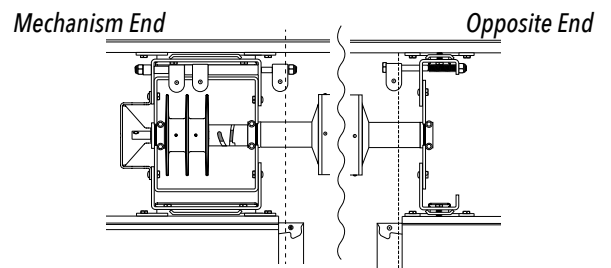

STEP 2: TRACK INSTALLATION

INSTRUCTIONS

The track system provides the pathways through which the cover and ropes move as the cover travels across the pool. Proper preparation is crucial for making sure that the cover runs smoothly.

Step 2.1 Measure track length and cut track to size.
IMPORTANT: Cut track at end that goes into the Polymer Box. Maintain factory edges along length of the track and at pulley end.

When determining track length, account for pulley spacers, MC0392 - Left & MC0393 - Right (found in kit KA-0155 - only used with 2 channel track), and allow for track to extend 1" into Polymer Box from end of retainer.

Step 2.2 Countersink and file track at each end in area shown. File down any sharp edges inside the track channel. Install splices with set bolt.

Step 2.3 Unwrap and unroll cover behind box, with matte side upward. Unwind ropes. Thread ropes through large channel of track and lead to end of track. Wind rope around pulley, and thread rope through back side. Repeat with other side.

Step 2.4 Place track into retainer, making sure pulley and splice stay in place. Push track as far forward as possible.

Step 2.5 Starting at pulley end of track, insert wedges under the track. Use rubber mallet to ensure wedge is fully seated. Trim last piece 1" shorter than the end of the retainer.

Step 2.6 With a 1/4" bit, drill through top of retainer, track, and bottom of retainer. Fasten track to retainer by pushing the Locking Pin (kit KA-0155) in through the holes.

Step 2.1

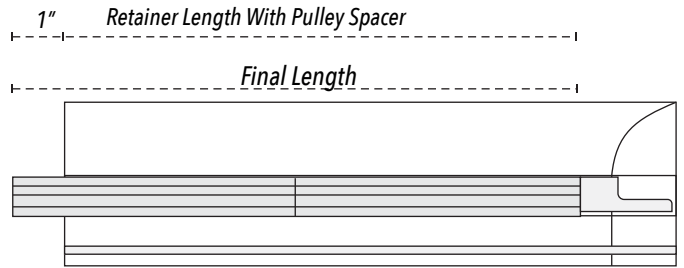

Step 2.2

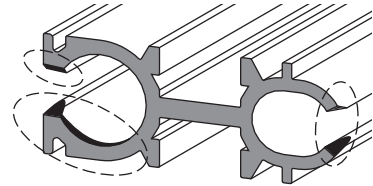

Step 2.3

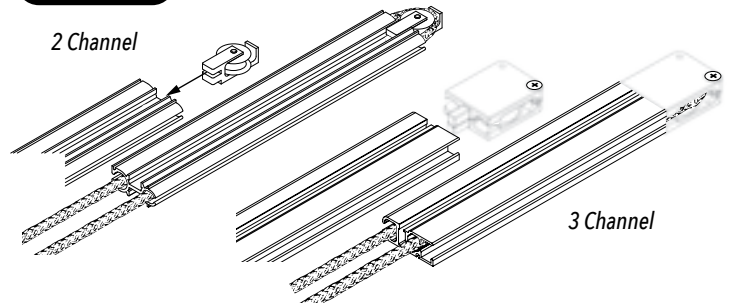

Step 2.4

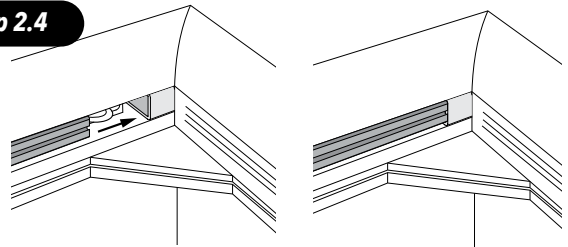

Step 2.5

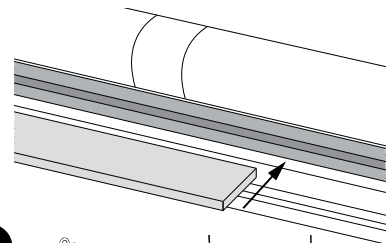

Step 2.6

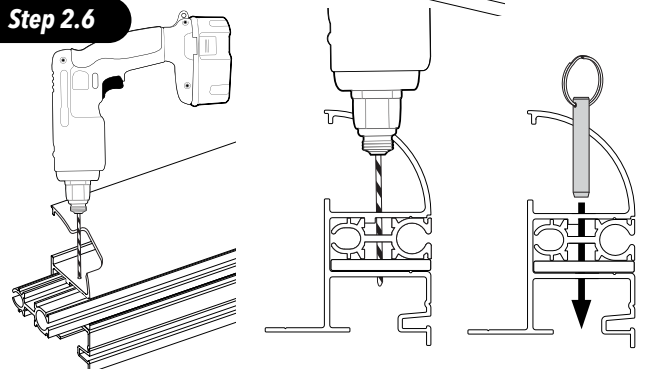

STEP 3: COVER INSTALLATION

INSTRUCTIONS

With cover still folded behind the box, install the filler strip in the wall cap. Access to this area will be difficult after the cover in place. Install the filler strip in the other end of the pool.

Step 3.1 Route ropes through pulleys and leave extra length lying on deck on motor end.

Step 3.2 Insert adjustable Dowels into each end of lead edge. Use rubber mallet to make sure dowel is seated properly. Using a 11/64" bit, drill a pilot hole 3/4" in from the end of the Dowel to prevent it from coming out of the Lead Edge. Insert screw to secure Dowel. Only drill through the lead edge.

Step 3.3 Attach glider bracket to glider on opposite side. Guide glider and cover corner into track while pulling gently on rope. Pull cover until approximately 6" into track. Tighten until snug, then back off slightly to allow the glider and glider bracket the ability to pivot slightly as cover travels across pool.

NOTE: If installing a sensor, install the magnet into the front of the webbing before inserting the cover into the track.

Step 3.4 Starting on the opposite side of the previously assembled glider, slide the front edge of the fabric into the lead edge channel. Hold the fabric taught and slide the lead edge until it reaches the glider bracket. Insert glider bracket into appropriate slot, and slide lead edge as far as possible. Cover extending beyond lead edge is deliberate.

Step 3.5 Adjust cover corner within lead edge at opposite end and insert lead edge screw and screw cover, through lead edge channel into front edge of cover.

Step 3.6 With lead edge screw and screw cover in place, starting at the carriage side and work towards the opposite side, pulling the slack of front of lead edge into lead edge channel.

Step 3.7 Insert remaining glider bracket into lead edge dowel, in same slot as opposite side. Attach bracket to glider with supplied hardware. Tighten until snug, then back off slightly to allow the glider and glider bracket the ability to pivot slightly as cover travels across pool.

Step 3.8 Feed glider and cover into track while gently pulling on rope.

Step 3.1

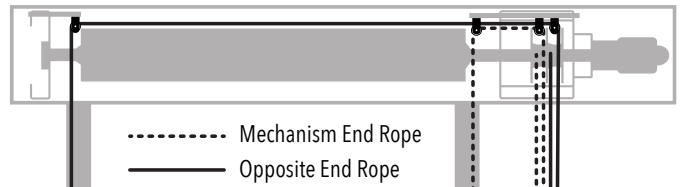

Step 3.2

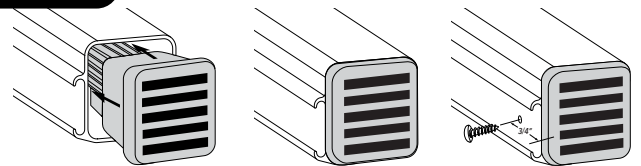

Step 3.3

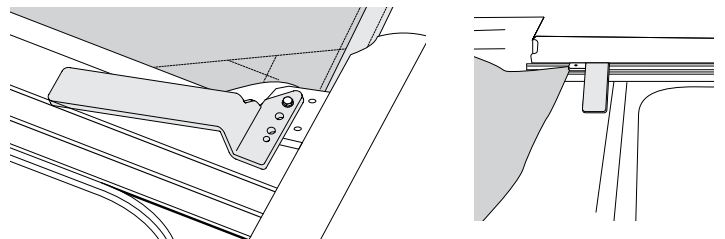

Step 3.4

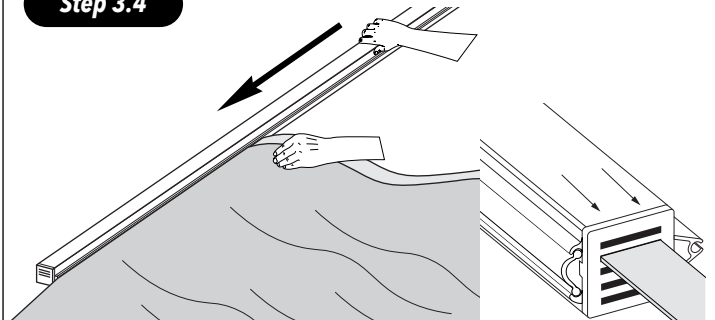

Step 3.5

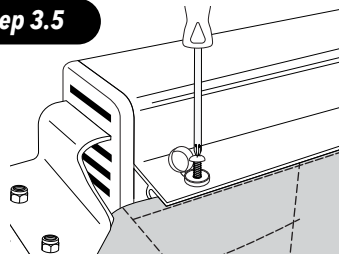

Step 3.8

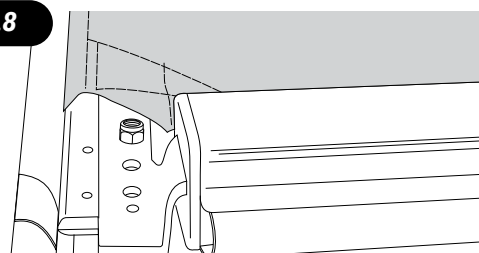

INSTRUCTIONS (CONTINUED)

Step 3.9 With both corners of cover in track, install guides. Use top half of guide as template and drill hole for hardware. Use 1/4" bit to make hole, then remove top half of guide, and use slightly larger bit to make installation easier.

Step 3.10 Fasten guides to track with supplied hardware. Insert remaining cap screw in back end of guide and fasten together with nut.

Step 3.11 Adjust lead edge until parallel to wall cap by gently pulling on appropriate rope. When satisfied with position, measure rope 8'-10' from front edge of box and cut each rope in same place.

IMPORTANT: Do not cut ropes when cover is closed.

Step 3.12 Tie knots in end of rope and insert into appropriate side of rope reel. Use controller to operate cover in "close" direction and guide excess rope onto reel in uniform manner.

Step 3.13 Continue to operate cover in "close" direction, until lead edge reaches end of pool. Cover should feed into track smoothly and evenly. If cover catches at guide, or one side of lead edge stops in track, release controller, and evaluate.

Step 3.14 Attach cover to tube according to diagram at right. Start at one end, align edge of webbing with edge of tube.

Step 3.15 Use controller to open cover enough to take up extra length of cover loosely around tube. Cuff edges of cover at each end. Open cover completely.

Step 3.16 Assemble Lid Seam Support Bracket (KA-0355) and Lid Lock components.

Step 3.9

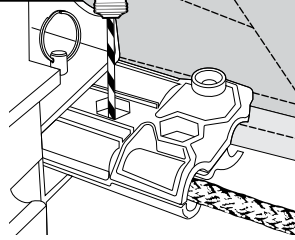

Step 3.10

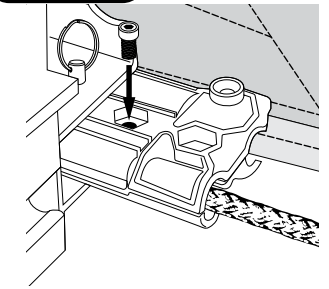

Step 3.11



Step 3.12

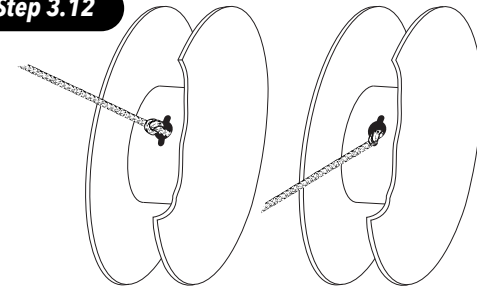

Step 3.13

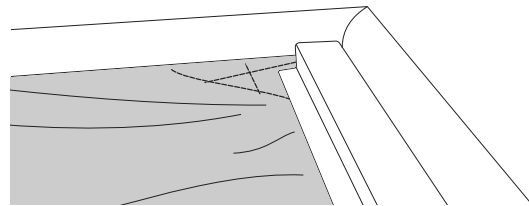

Step 3.14

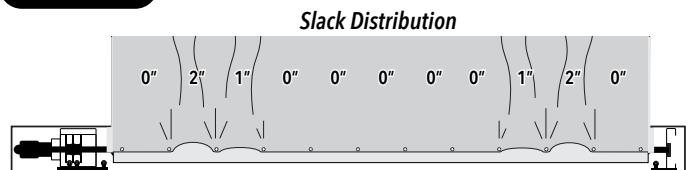

Step 3.16

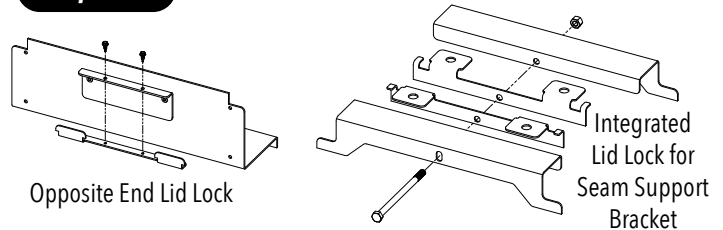

INSTRUCTIONS (CONTINUED)

Step 3.17 Attach left and right fascia by placing into channel on front of lid, bottom edge first and then tilt up and in.

Step 3.18 Measure the distance between the left and right pieces to determine the middle piece. Cut to appropriate length and attach in the same way as the left and right pieces.

Step 3.17

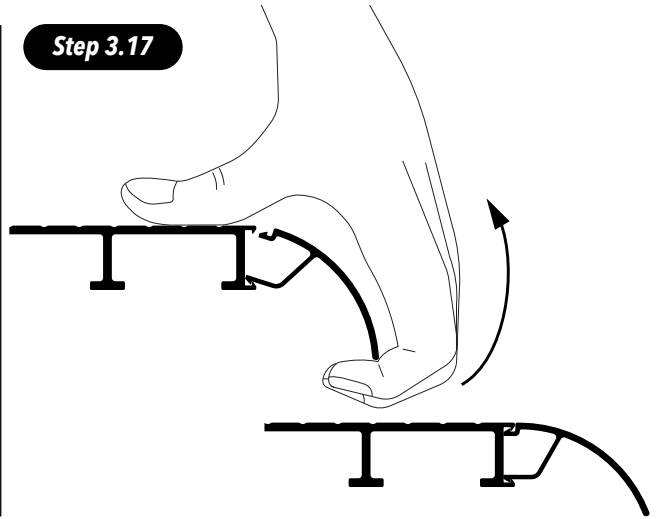

STEP 4: COVER ADJUSTMENT

INSTRUCTIONS

If the cover opens crookedly, adjust the rope that corresponds to the side that is **closest to the lid**.

III. 4.1 In illustration 4.1, the **RIGHT** side ropes need to be adjusted. Take all rope off the rope reel. **SHORTEN** the rope for this side by adjusting the location of the knot that is inserted into the rope reel approximately the same distance that the cover is crooked. Place rope back onto the reel and close cover.

III. 4.2 In illustration 4.2, the **LEFT** side rope needs to be adjusted. Take all rope off the rope reel. **SHORTEN** the rope for this side by adjusting the location of the knot that is inserted into the rope reel approximately the same distance that the cover is crooked. Place rope back onto the reel and close cover.

III. 4.1

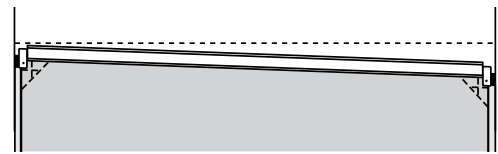

III. 4.2

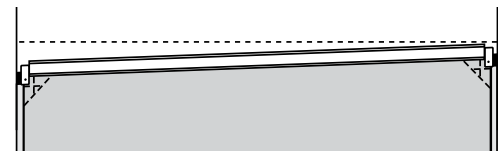

TECHNICAL SUPPORT

If you have any questions about these installation procedures, please contact Technical Support (800) 878-5789 Monday through Friday, 8 am - 5 pm EST.

Automatic Pool Covers, Inc.

(800) 878-5789 • automaticpoolcovers.com

UNDER TRACK

Drilled Under Track Installation Instructions

TOOLS NEEDED

- | | | | |
|--------------------------------|----------------------------|---|---|
| 1. Cordless drill | 2. 12" Torpedo level | 3. Flat shovel | 4. Wrenches/sockets: 7/16", 1/2", 9/16" |
| 5. Hammerdrill | 6. 1/2" Round bastard file | 7. Box knife | 8. Phillips & Flat-head screwdriver |
| 9. Wire strippers with cutters | 10. Scissors | 11. Rubber mallet | 12. Saw (with aluminum blade) |
| 13. Extension cords | 14. Hammer | 15. 6-8 "C" clamps | 17. 25' & 100' tape measures |
| 18. Hacksaw w/18 tooth blade | 19. 100' string | 20. Drill bits: 1/4", 5/32", 11/64", #2 & #3 Phillips, 1/4" x 4" & 6" masonry bit, 1/2" x 4" & 6" masonry bit, 5/16" nut driver, 7/16" socket driver, countersink | |

STEP 1: LAYING OUT THE TRACK

INSTRUCTIONS

- Step 1.1** Verify the track space that was ordered for your system. This can be found on all of the packing slips. **Ex. T/W [FT] 20.25 T/L [FT] 43**
The mechanism, main tube, lead edge and cover are based off of the ordered track space.
- Step 1.2** Lay the tracks parallel to the pool on top of the coping down both sides with the pulley housings, found in kit KA-0181 (for standard track), or in kit KA-0342 (for 3 channel track) at the opposite end from the recessed housing. Insert pulley housing in one end of the track and line it up with the end of the pool wall. Make sure to leave room for any tile work to be done but far enough under the coping to assure the cover will close completely. Take the next piece of track on the same side and butt it up against the previous one.
- NOTE:** If the track length is over 44', splice a third piece of track per side. Never install a piece of track that measures less than 5'. If needed, cut one of the full pieces of track down to accommodate the third piece.
- Step 1.3** With track extending into the housing, measure the track 7/8" from the edge of the housing. Cut the track with a hacksaw or circular saw.
- HINT:** Do not cut the track where the splices meet. It is best to keep the manufactured cuts between connecting tracks.
- Step 1.4** It is important there is a track screw within 6" from the bond beam. Depending on the location of the pre-drilled hole, it may be necessary to drill an additional 1/4" hole and countersink to secure this critical part of the track.
- 1.5 File and countersink all ends of the track for both sides to make sure there are no sharp edges to rub on the rope or webbing.

FOOT DECIMAL TO INCH CONVERSION											
Decimal	.08	.17	.25	.33	.42	.50	.58	.67	.75	.83	.92
Inches	1	2	3	4	5	6	7	8	9	10	11

Step 1.2

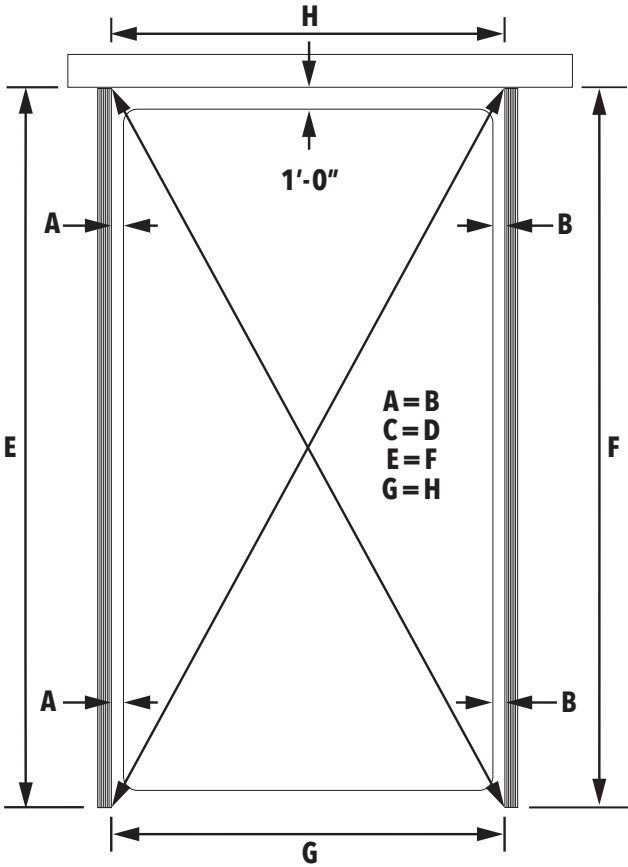

STEP 2: CLAMPING TRACKS TO COPING

INSTRUCTIONS

HINT: Install track after tile and grout work is complete to ensure tracks are kept clean.

Step 2.1 Start with the piece of track at the far end of the recessed housing. Using "C" clamps, clamp the track to the coping being sure not to allow the coping to overhang the track more than 1". Insert a piece of wood, cardboard, etc. to protect the deck from scratches. Be sure that top of clamp is inline with the bottom.

Step 2.2 Insert a track splice, found in kit KA-0181 (for standard track), or insert splice and locating pins in kit KA-0342 (for 3 channel track), into the middle channel of the track.

Step 2.3 Align the next piece of track with the track splice and butt it up against the first piece of track. Using "C" clamps, clamp the track to the coping being sure not to allow the coping to overhang the track more than 1".

NOTE: Clamp the tracks to the coping making sure the splice is tight. If the tracks are uneven at the splice, "shim" a track so the rope channels are aligned.

Step 2.1

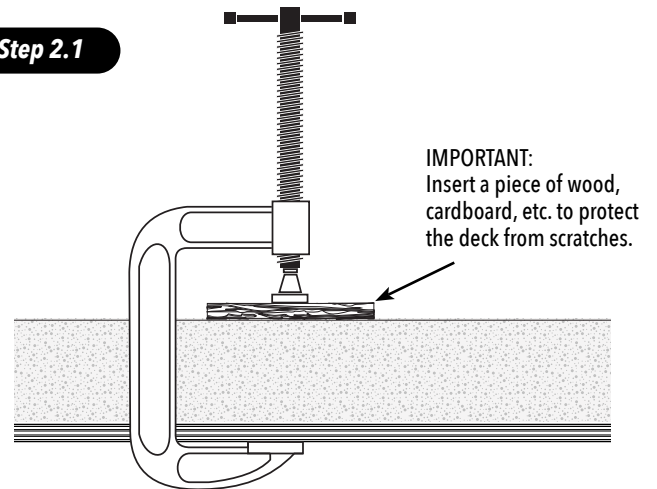

STEP 3: DRILLING & SECURING TRACK

INSTRUCTIONS

Step 3.1 With the tracks clamped in place, use a hammer drill with a 1/4" masonry bit to drill through the track and coping, approximately 2". Be careful not to drill through thin coping or brick mortar.

NOTE: If holes in tracks are lined up over mortar joints, drill additional holes using a regular drill with a 1/4" masonry bit, not a hammer drill. If there are end or corner steps to the pool, you may need to use an angle drill to drill and secure the tracks above the step area.

Step 3.2 Locate kit KA-0006 and insert each track screw into the red anchors. Hand tighten the track screw into the red anchor until tight.

Step 3.3 Tap in the track screw and anchor through the track hole until the head of the screw is 1/2" from the track.

IMPORTANT: The anchor must be set into the coping before tapping into place to avoid breaking the anchor.

Step 3.4 Hand tighten or use an electric or cordless drill with a #3 bit to tighten the track screws into the tracks. **Be careful not to go too fast which might crack the coping or burr the top of the track screw.**

Step 3.1

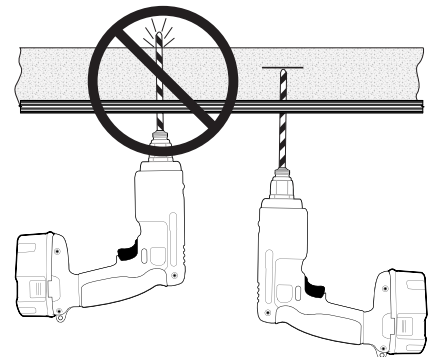

Step 3.3

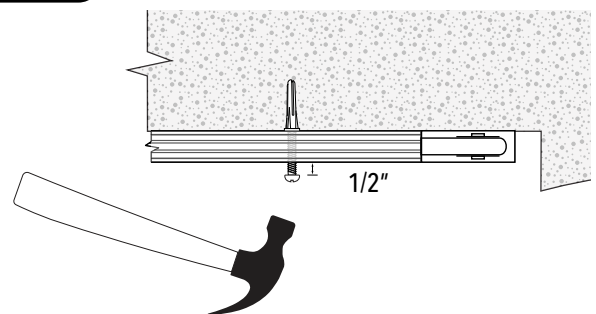

STEP 4: INSTALLING AUTOGUARD SYSTEM

INSTRUCTIONS

Step 4.1 Attach the main tube to the mechanism end and opposite end castings with (4) 5/16"-18 x 0.75" bolts and lock washers, located in kit KA-0183 using a 1/2" wrench.

Step 4.2 Starting at the mechanism end, secure the mounting brackets to the recessed housing using the appropriate hardware.

- Wood housing use lag bolts for (in kit KA-0045)
- Concrete housing use screws/red anchors (in kit KA-0044)

Repeat the process on the opposite side.

Step 4.3 If using an APC, Inc. polymer box, install channel plates into box rail for mechanism end and opposite end located in kit KA-0326. Install drop in brackets using (2) 3/8"-16 x 0.75" bolts. Leave brackets loose to allow the unit to be centered from left to right. **Make sure to use the holes marked "UT".**

Step 4.4 Set the unit into the recessed housing and align the center mark of the tube to the mark made on the front of the recessed housing.

Step 4.5 Measure the distance between the two tracks and find the halfway point and mark it on the front of the recessed housing.

HINT: Usually the top of the mechanism brackets is level with the bottom of the track retainer. Use the rope angle to dictate how high to mount the mechanism and opposite end. The rope should come straight out of the track into the pulley assembly, while maintaining a slight downward angle. This does not apply if using an APC, Inc. polymer box.

Step 4.6 Once the system is secured, make sure the unit is leveled and centered from front to back and left to right. Tighten all of the hardware on the mechanism with a 1/2" wrench. If system is mounted in an APC, Inc. polymer box, make sure to secure all of the 3/8"-16 mounting bolts with a 9/16" socket and ratchet.

Step 4.7 On wood and concrete box, and reusable from coping box, install two eyelets found in kit KA-0183 on the backside of the recessed housing at least 4' from each end of the track. Make sure the eyelets are in-line with the pulleys on the mechanism end and opposite end mounting brackets.

Step 4.1

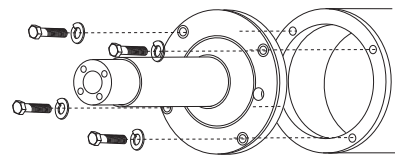

Step 4.2

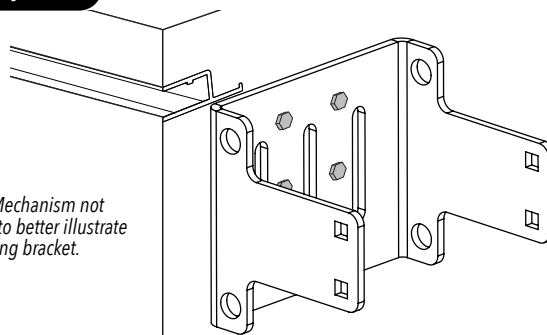

Step 4.3

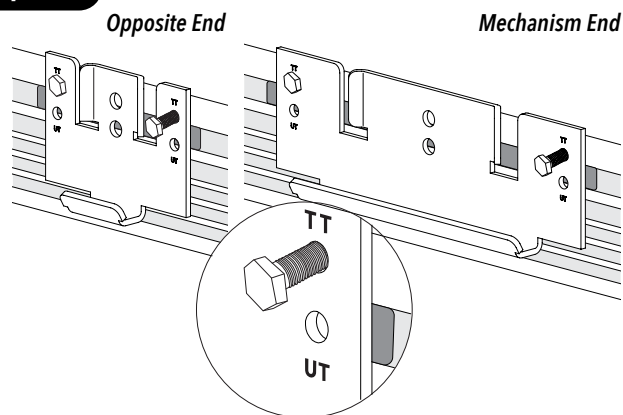

Step 4.5

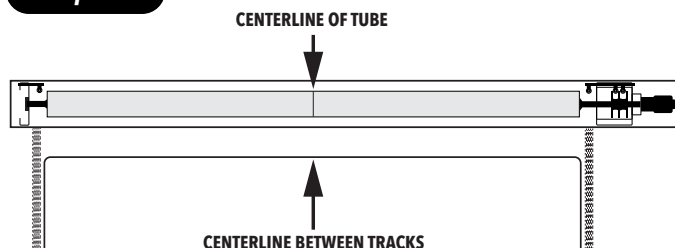

Step 4.7

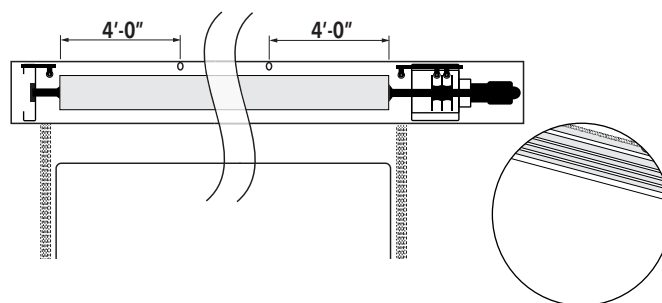

STEP 5: INSTALLING TRACK INTO RETAINER

INSTRUCTIONS

Step 5.1 Lay the tracks parallel to the pool on top of the coping down both sides with the pulley housings, found in kit KA-0155 (for standard track), or in kit KA-0342 (for 3 channel track), at the opposite end from the recessed housing. Take a piece of track with the pulley housing attached and line it up with the pulley spacers, found in kit KA-0155 (for standard track), or in kit KA-0342 (for 3 channel track), at the end of the retainer (there is a left and right pulley spacer so make sure you install them into the retainer correctly). Take the next piece of track on the same side and butt it up against the previous track. Insert the correct pulley spacer into the retainer as far back as it can go.

NOTE: If the track length is over 44', splice a third piece of track per side. Never install a piece of track less than 5'. If needed, cut one of the full pieces of track down to accommodate the extra.

Step 5.2 Once track is laid out on the deck correctly, allow 7/8" of track to hang into the housing and make a mark to cut with a hacksaw or circular saw.

HINT: Do not cut the track where the splices meet. It is best to keep the manufactured cuts at the splice.

Step 5.3 File and countersink all ends of the track for both sides to make sure there are no sharp edges to rub on the rope or webbing.

Step 5.4 Insert the track splice, located in kit KA-0155 (for standard track) or insert splice and locating pins in kit KA-0342 (for 3 channel track), and secure tracks together.

HINT: For strongest connection, offset the track splice and the corresponding retainer splice approximately 3".

Step 5.5 Lay cover to the left side of the system and carefully remove the wrap. To unroll cover properly, be sure label is facing the pool water.

NOTE: Make sure the matte side (smooth side) of the cover is facing upward showing the warning label.

Step 5.6 Carefully unwind the ropes making sure they do not get tangled.

IMPORTANT: DO NOT CUT ROPES AT THIS TIME.

Step 5.7 With a 3' leader, snap the rope into the front channel (large) of the track and pull the rope down to the end pulley. Feed the rope around the end pulley, down the back channel of the track, while maintaining a 3' leader. Repeat for the other side.

HINT: Insert the guide in kit KA-0115 (standard track), or in kit KA-0342 (3 channel track), to help keep the rope in the track channel.

Step 5.8 Carefully place the track into the retainer, making sure the track and splice stay in place. Push the track all the way against the pulley spacer.

HINT: Tie the rope in a knot at the end of the track to keep the tracks from coming apart.

Step 5.9 Starting at the pulley end of the track, insert the wedges under the track. Use a rubber mallet to ensure the wedge is fully seated. Trim the last piece to fit at the guide end of the track.

Standard Track

Step 5.1

Step 5.2

Step 5.4

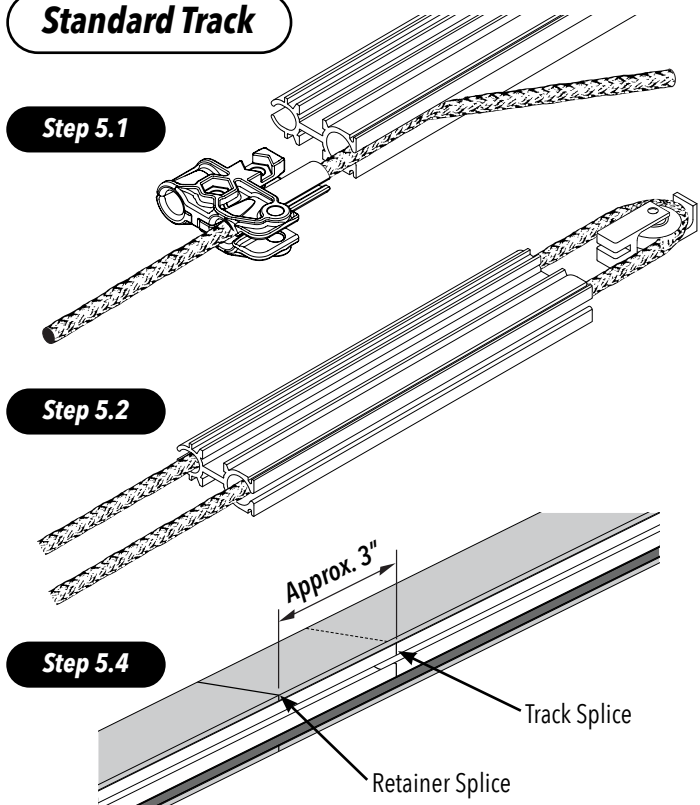

3 Channel Track

Step 5.1

Step 5.2

Step 5.2

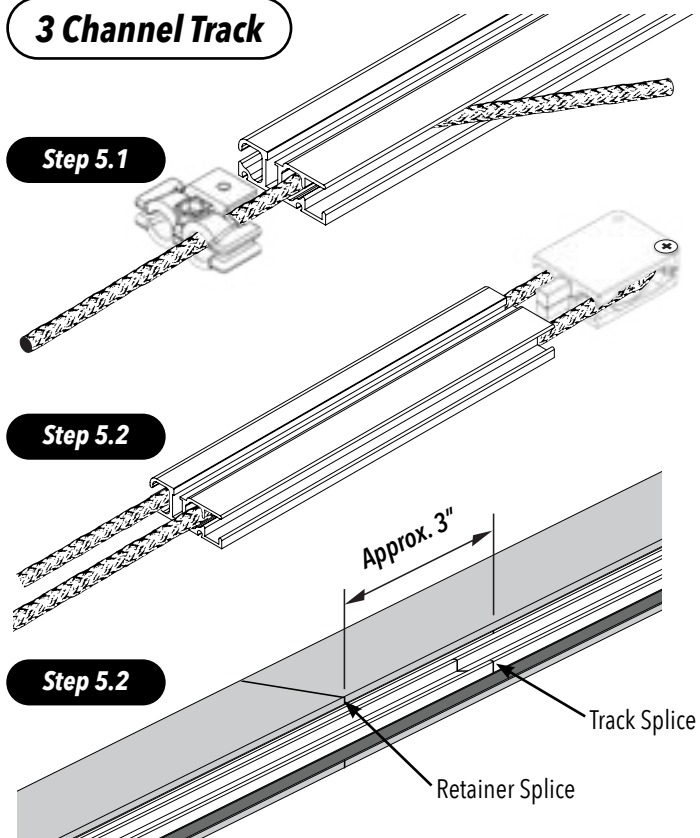

INSTRUCTIONS (CONTINUED)

Step 5.10 Drill through the retainer and track with a 1/4" drill bit. Fasten the track to the retainer with the supplied hardware, found in kit KA-0155 (for standard track), or in kit KA-0342 (for 3 channel track).

NOTE: If the concrete stops were used with the retainer and reusable forms, drill through the hole provided in the tab of the concrete stop. This will allow you to secure the track with the hardware provided in KA-0155 (for standard track), or in kit KA-0342 (for 3 channel track).

Step 5.11 Feed the opposite side rope through the opposite end pulley across the back of the box through the eyelets and through all 3 pulleys on the mechanism end and leave the extra length of rope lying on the deck.

Step 5.12 Feed the motor side rope through the first 2 pulleys on the mechanism end and leave the extra length of rope lying on the deck.

Step 5.12

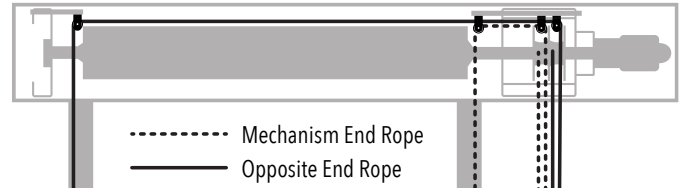

STEP 6: COVER INSTALLATION

INSTRUCTIONS

Step 6.1 Insert the lead edge dowels into each end of the lead edge. Pre-drill a hole through the lead edge and use a 1/2" screw to secure the dowels to the lead edge.

Step 6.2 Starting at the opposite end, insert the front of the cover into the track about 6" by gently pulling on the rope.

Step 6.3 Attach the proper glider bracket to the glider using the supplied hardware in the glider.

NOTE: Do not over-tighten the glider bracket to the glider as it may break. Glider bracket must be able to pivot.

Step 6.4 Starting on the motor side, slide the front edge of the cover into the lead edge channel. Hold the cover taut and slide the lead edge until it reaches the glider bracket. Insert the glider bracket into one of the slots of the lead edge dowel.

Step 6.5 Adjust the cover corner in the lead edge and secure with a 1/2" screw, found in kit KA-0183, 1" in from the edge.

Step 6.6 With the lead edge screwed in place, pull the cover slack starting at the opposite end and work towards the motor side, distributing the slack even throughout the length of the lead edge.

Step 6.7 Adjust the cover corner in the lead edge and secure it with a 1/2" screw, found in kit KA-0183, 1" in from the edge.

Step 6.8 Install the remaining glider bracket into the lead edge dowel, in the same slot as the opposite side. Attach the glider bracket to the glider using the supplied hardware in the glider.

HINT: If your system is setup for a key switch, install the open magnet, found in kit KA-0184, into the front of the webbing on the motor side. Pull the white strip off of the magnet and insert into the webbing. The magnets will travel approximately 1" past the sensor before the cover stops. Take this into consideration when installing the magnets.

Step 6.9 Insert the glider into the track about 6" while gently pulling the rope.

Step 6.10 With both corners of the cover in the track, install the guides, found in kit KA-0155 (for standard track), or in kit KA-0342 (for 3 channel track), and pre-drill the holes using a 1/4" drill bit.

Step 6.11 Fasten the guides, found in kit KA-0155 (for standard track), or in kit KA-0342 (for 3 channel track), to each track with the supplied hardware.

Step 6.3

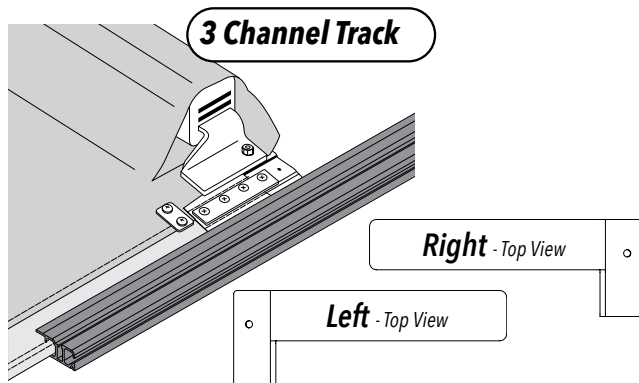
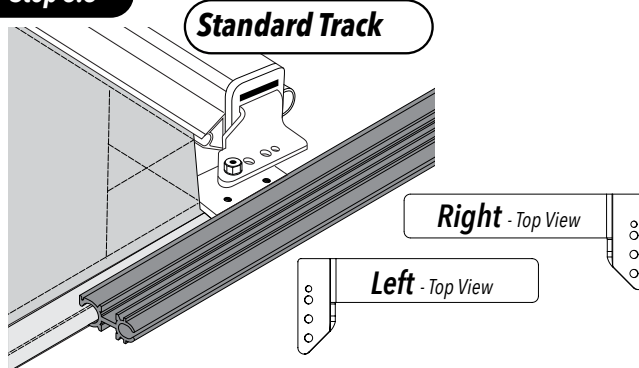

Step 6.4

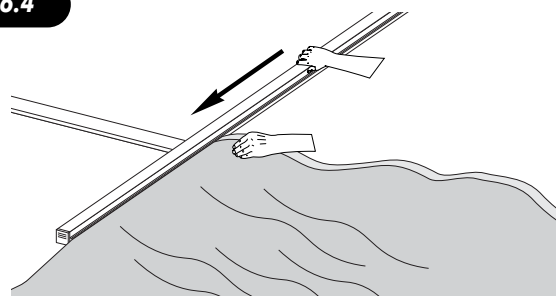

Step 6.5

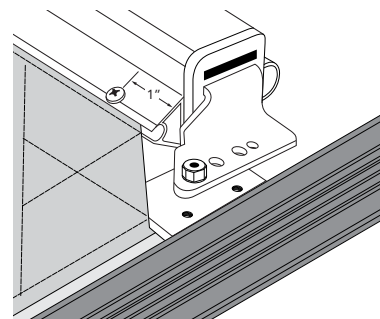

INSTRUCTIONS (CONTINUED)

Step 6.12 Adjust the lead edge until it is parallel to the waters edge by gently pulling on the appropriate ropes. When satisfied with the position, cut the ropes evenly at 6' to 8' from the front edge of the recessed housing.

Step 6.13 Tie knots at each end of the rope and insert the knot into the appropriate side of the rope reel. Use the controller to operate the system in the "close" direction to help guide the excess rope onto the rope reel evenly. **CAUTION: Keep hands clear so they do not get wrapped up in the rope reel.**

Step 6.14 Continue to close the cover until the lead edge reaches the end of the pool. The cover should feed into the track smoothly and evenly. If the cover catches at the guide, or if one side of the lead edge stops, release the controller and evaluate.

Step 6.15 Attach the cover to the tube, allowing the slack as shown, provided with 1/2" screws located in kit KA-0183 into the holes pre-drilled every 18". **Make sure to align the edge of the webbing with the edge of the tube. It is important that the sections with 0" of slack be taut.**

Step 6.16 Use the controller to open the cover enough to take up the extra length of cover loosely around the tube. Cuff the edges of cover at each end. **If system is setup for a key switch, go ahead and install the close magnet, found in kit KA-0184 in the tail end of the webbing on the motor side. Carefully cut a slit in the webbing 6" behind the guide. Pull the white strip off of the magnet and insert into the webbing. The magnets will travel approximately 1" past the sensor before the cover stops. Take this into consideration when installing the magnets.**

Step 6.17 Run the cover 3 to 4 times open and close to make sure the magnets are set properly (if applicable) and the cover is running square to the pool. If not, follow the diagrams to adjust the cover.

Step 6.12



Step 6.15

Slack Distribution

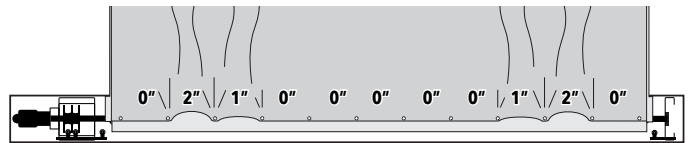

Step 6.17

If the cover opens crookedly, adjust the rope that corresponds to the side that is closest to the lid.

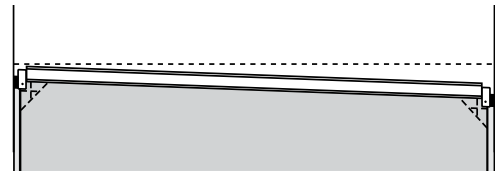

The **RIGHT** side rope need to be adjusted. Take all rope off the rope reel. **SHORTEN** the rope for this side by adjusting the location of the knot that is inserted into the rope reel approximately the same distance that the cover is crooked. Place rope back onto the reel and close cover.

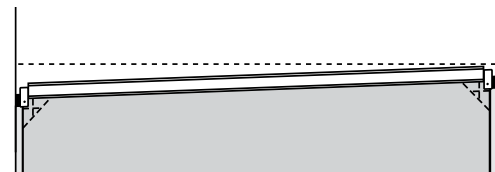

The **LEFT** side rope need to be adjusted. Take all rope off the rope reel. **SHORTEN** the rope for this side by adjusting the location of the knot that is inserted into the rope reel approximately the same distance that the cover is crooked. Place rope back onto the reel and close cover.

STEP 7: INSTALLING STANDARD MAIN LID

INSTRUCTIONS

Step 7.1 Layout the lid bracket sleeves and space accordingly. The spacing should be 1' from the track on the outer lid bracket sleeves and then space the remaining lid bracket sleeves equally.

Step 7.2 Secure the lid bracket sleeves 1/4" down from the top of the recessed housing with supplied hardware. Lag bolts for wood housing, found in kit KA-0045, track screws/red anchors for a concrete housing found in kit KA-0044 and if it is in an APC, Inc. polymer box, then insert the channel plates and secure with (2) 3/8"-16 x 1.00" bolts.

NOTE: Bracket may need to be bent so it is level and lid rests flush on bracket appropriately.

Step 7.3 Install lid brackets into lid bracket sleeves.

Step 7.4 Slide the lid hinge onto the standard aluminum main lid.

Step 7.5 Center lid assembly between the track on top of the brackets. Make sure there is equal distance on both sides of the track and that the lid assembly covers the front and back of the recessed housing. Cut any extra hinge with a hacksaw or circular saw making sure to leave approximately 1" of overhang on both ends of the housing. Make sure to file both ends of the hinge so there are no sharp edges or burrs.

NOTE: It is best to cut the longer section of lid hinge if you have to use a 5' section of extra lid hinge.

Step 7.6 With the main lid set in place, drill 1/4" holes through the lid hinge so the holes line up with the wood box (if applicable) starting 3" to 4" from each end of the hinge and then space the other holes every 4'. If securing to concrete housing, be sure there is 2" of concrete between drilled holes and inside edge of housing.

Step 7.7 Secure the lid hinge with the supplied hardware. Lid screws for a wood housing found in kit KA-0183 or lid screws/red anchors for a concrete housing found in kits KA-0044 and KA-0183.

Step 7.8 Make sure the main lid is centered over the tracks and slide lid end on the motor side and mark it so it is even with the hinge. Cut the lid end with a jigsaw or circular saw and file both edges.

HINT: Cut the outside edge of the lid end to keep the manufactured cuts of the lid and lid end together.

Step 7.9 Install the remaining portion of the lid end and slide it on the opposite side and mark it so it is even with the hinge. Cut the lid end with a jigsaw or circular saw and file both edges.

HINT: Cut the outside edge of the lid end to keep the manufactured cuts of the lid and lid end together.

Step 7.10 The main lid will sit up higher than the lid ends. The front of the main lid will have to be cut to match the profile of the lid end. Cut the lid lip to allow the lid to sit flush with the deck. **This is usually achieved with a hacksaw or jigsaw.**

NOTE: Be sure the lid hinge, lid ends and main lid are filed thoroughly and do not have any sharp edges.

Step 7.1

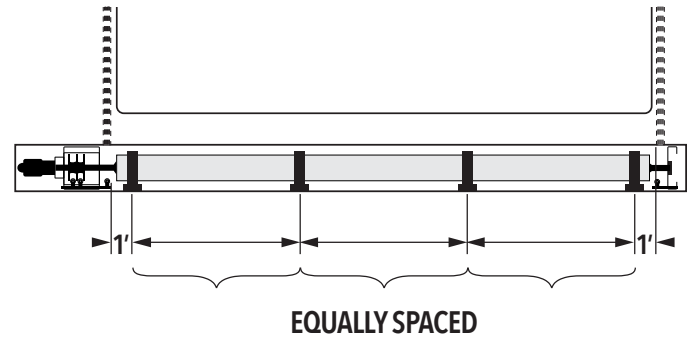

Step 7.10

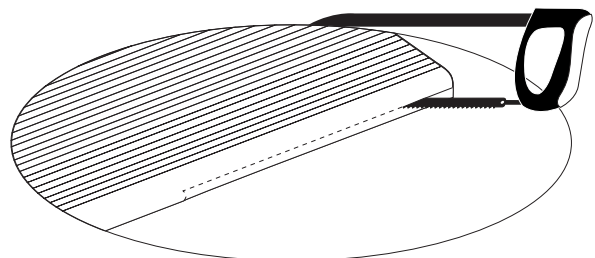
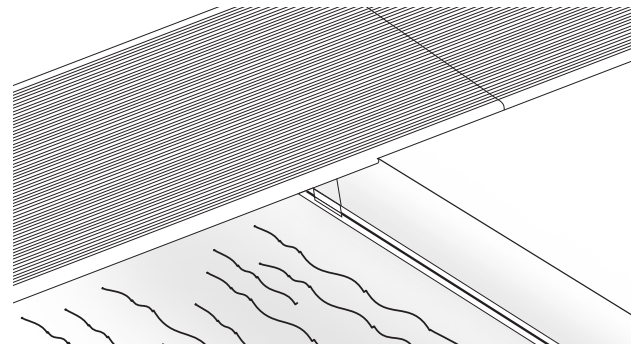

STEP 8: INSTALLING LID TRAYS OR CUSTOM LID

INSTRUCTIONS

- Step 8.1** Space the lid trays or custom lids across the back of the housing starting on the opposite side.
- Step 8.2** Mark on the inside of the housing where the lids will be straddling the lid bracket arms.
- Step 8.3** Locate your lid bracket bases and install on the back of the housing. The thickness of the lid tray or custom lid determines how high to mount the lid bracket base. Depending on what bracket is being used you might need to use a 3/8" or 1/2" masonry bit for the wedge anchors. Use the lid bracket base as a template and mark the back of the box to hammer drill your holes.
- Step 8.4** Tap in the supplied wedge anchors and install the lid bracket base and tighten down the bolts so the lid bracket base can not slide down.
- Step 8.5** Once all of the lid brackets are secure, install the lid trays or custom lid and level each bracket accordingly.

NOTE: Assemble Atlas Lid Brackets using the instructions

NOTE: Make sure to put the cover pump on top of the cover when it is in the closed position and not being used.

Atlas Bracket Installation

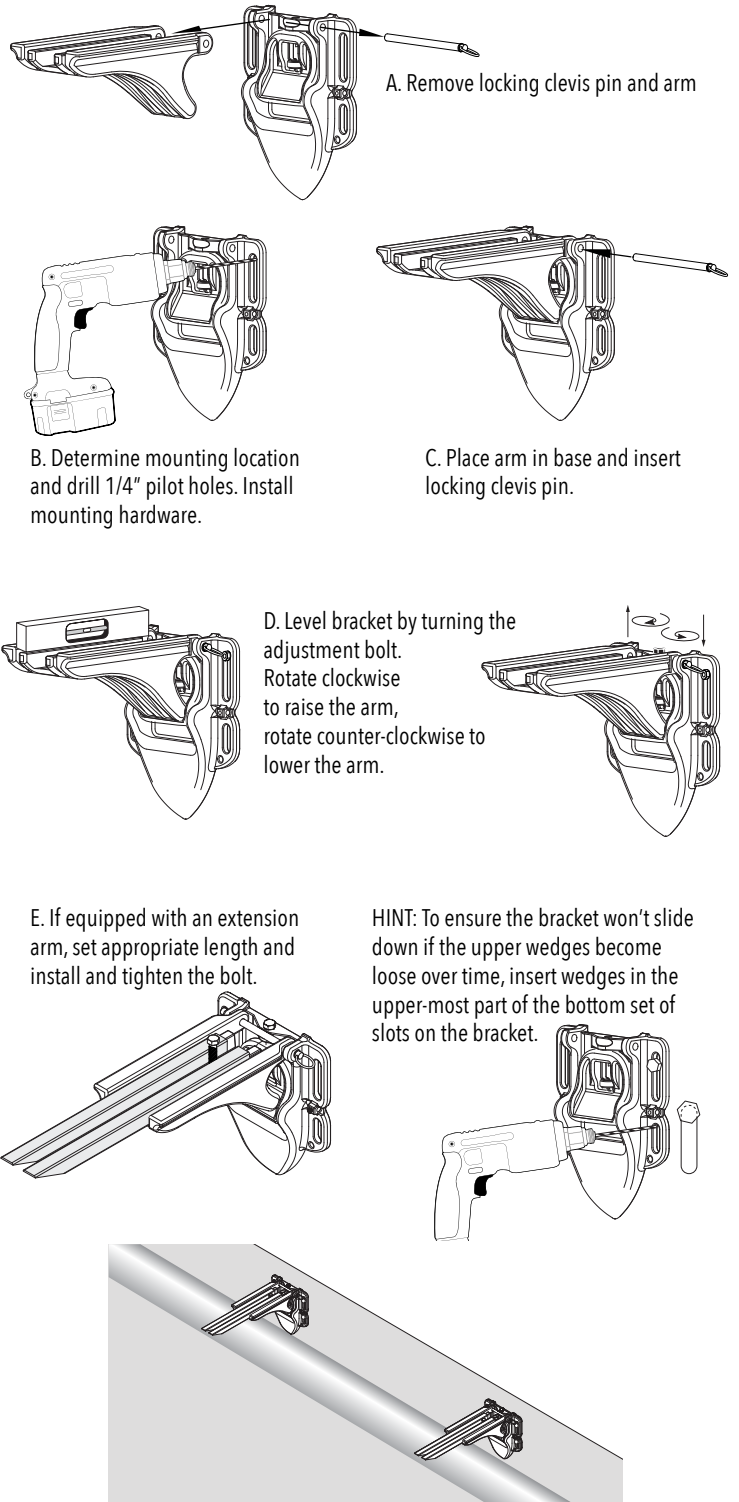

TECHNICAL SUPPORT

If you have any questions about these installation procedures, please contact Technical Support (800) 878-5789 Monday through Friday, 8 am - 5 pm EST.

Automatic Pool Covers, Inc.

(800) 878-5789 • APC-Mfg.com

TOP TRACK

Top Track Installation Instructions

TOOLS NEEDED

- | | | | |
|----------------------------------|--|--------------------------------------|-----------------------------|
| 1. Cordless drill | 2. Hammer drill | 3. Flat-head & Phillips screwdrivers | 4. Hammer |
| 5. Hacksaw with 18 tooth blade | 6. 12" Torpedo level | 7. 1/2" Round bastard file | 8. Wire strippers w/cutters |
| 9. Saw (with aluminum blade) | 10. 25' & 100' tape measures | 11. 100' string | 12. Flat shovel |
| 13. Box knife | 14. Scissors | 15. Extension cords | 16. Countersink |
| 17. Wrenches: 7/16", 1/2", 9/16" | 18. Drill bits: 1/4", 5/32", 11/64" | 19. Driver bits: #2 & #3 Phillips | 20. 5/16" nut driver |
| 21. Socket driver: 7/16" | 22. Masonry bits: 1/4" x 4" & 6" & 1/2" x 4" | | |

STEP 1: LAYING OUT THE TRACK

INSTRUCTIONS

- 1.1 Verify the track space that was ordered for your system. This can be found on all of the packing slips. **Ex. T/W [FT] 20.25 T/L [FT] 43**
The mechanism, main tube, lead edge and cover are based off the ordered track space.
 - 1.2 Determine **TRACK LENGTH**: Measure from the inside front of the recessed housing to the opposite end of the pool and **add 2'** for overlap.
 - 1.3 Lay the tracks out on one side of the pool, insert a track splice, found in kit KA-0178 and cut off any excess track with a hacksaw or circular saw at the recessed housing end. **Make sure to file and countersink all ends of the tracks.**
- HINT: Do not cut the track where the splices will meet. It is best to keep the manufactured cuts at the splice.**
- NOTE: If the track length is over 44', splice a third piece of track per side. Never install a piece of track less than 5'. If needed, cut one of the full pieces of track down to accommodate the extra.**
- 1.4 Drill new holes 3" from the splice end if the manufactured holes are cut off. Use a 1/4" drill bit and countersink. File and countersink all ends of the tracks to make sure there are no sharp edges for the rope or webbing to rub on.
 - 1.5 Align the tracks with the inside edge of the recessed housing on both sides and measure the distance between the tracks. **This is the EDGE TO EDGE measurement. Add 1" for your TRACK WIDTH.**
 - 1.6 Place the tracks equal distance from each side of the pool. The track space needs to be the same at the recessed housing, the splice and the opposite end to make sure they are parallel.
 - 1.7 To insure the layout is square, take a diagonal measurement and adjust accordingly.

FOOT DECIMAL TO INCH CONVERSION											
Decimal	.08	.17	.25	.33	.42	.50	.58	.67	.75	.83	.92
Inches	1	2	3	4	5	6	7	8	9	10	11

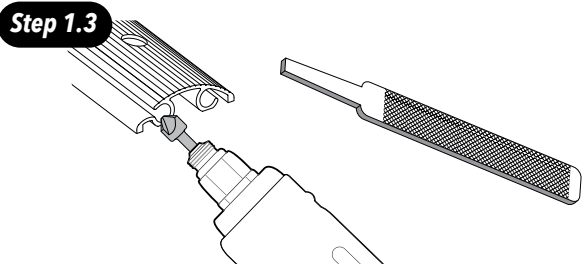
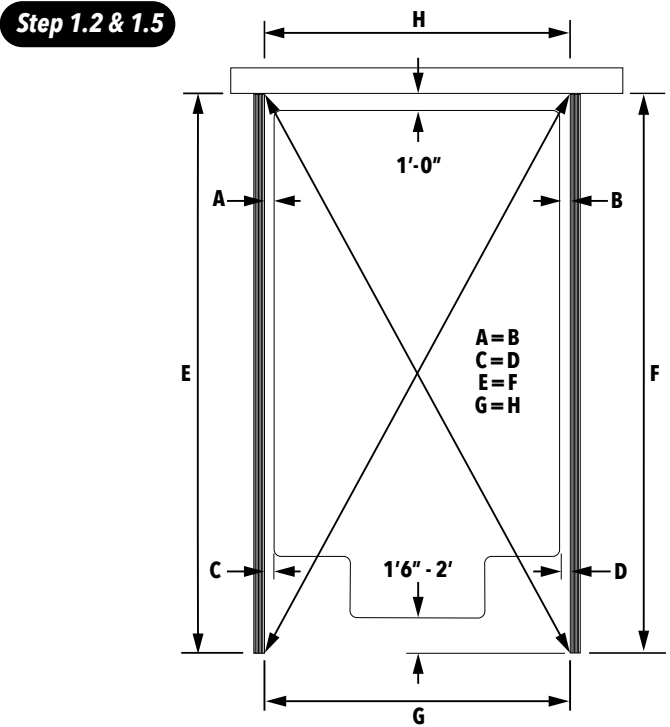

STEP 2: INSTALLING THE TRACK

INSTRUCTIONS

- 2.1 Locate kit KA-0006 and insert each track screw into the red anchors by twisting the track screw into the red anchor.
- 2.2 Starting at the unit end, use a hammer drill with a 1/4" masonry bit and drill through the closest hole 3" deep.
- 2.3 Install a track screws and anchors found in kit KA-0183 by tapping it through the track into the deck so that the anchor is flush to the top of the concrete. **Do not tighten down the track screw at this time.**
- 2.4 Insert a Track Splice at each location tracks meet and make sure the splice is snug. Walk down to the opposite end and drill the last hole 3" deep.
- 2.5 Install one of the track screws and anchors by tapping it through the track into the deck so that the anchor is flush to the top of the concrete. **Do not tighten down the track screw at this time.**

HINT: Stand on the track while drilling to prevent the track from shifting.

- 2.6 To keep the track straight, run a string down the track from one end to the other by using the track screws installed, allowing the rest of the holes in the tracks to line up.
- 2.7 Drill the remaining holes and insert the track screws and anchors. **Do not tighten down.**
- 2.8 Repeat steps for the opposite side.

NOTE: An angle drill may needed to drill holes under a slide.

- 2.9 When all the tracks are drilled and loosely secured with the track screws and anchors, find the pulley casting assembly in kit KA-0178 and insert the pulley casting assembly on the far end of the pool.
- 2.10 Tap the top of the pulley casting to create a mark in the concrete deck.
- 2.11 Remove the pulley casting and drill a 1/2" diameter hole 1/2" deep on the mark. This allows the pulley nut to recess into the deck.
- 2.12 Repeat the steps for the opposite side.

Step 2.2

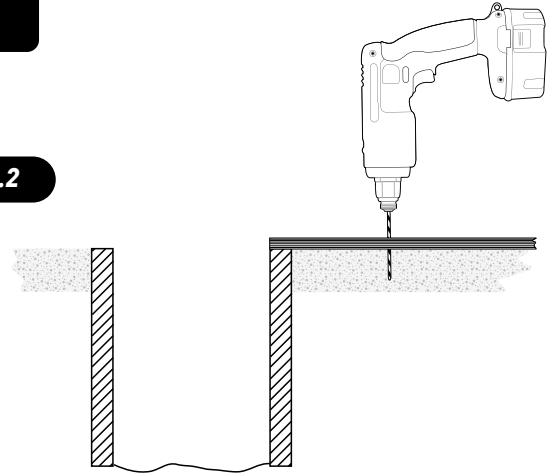

Step 2.4

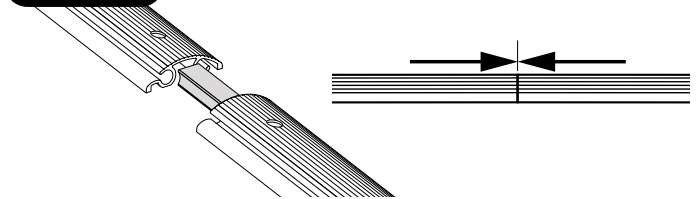

Step 2.5

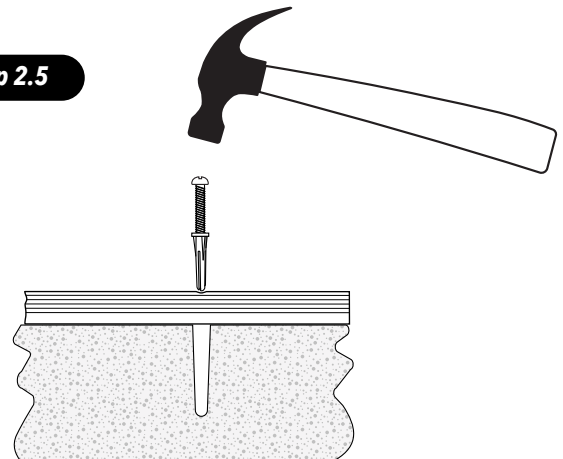

Step 2.10



Step 2.11

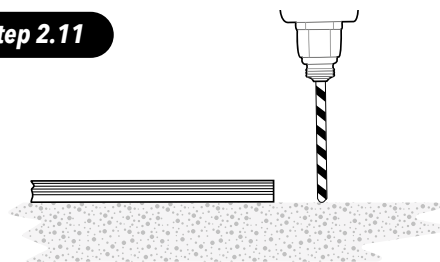

STEP 3: INSTALLING AUTOGUARD SYSTEM

INSTRUCTIONS

Install the Motor and Control panel following the Wiring Diagram enclosed with Motor

- 3.1 Attach the main tube to the mechanism end and opposite end castings with (4) 5/16"-18 x 0.75" bolts and lock washers found in kit KA-0183 with a 1/2" wrench.
- 3.2 Measure the distance between the two tracks and find the halfway point and mark it on the front of the recessed housing.
- 3.3 If using an APC, Inc. polymer box, install both channel plates for mechanism end and opposite end found in kit KA-0326. Install drop-in brackets using (2) 3/8"-16 x 0.75" bolts. Leave brackets loose to allow the unit to be centered from left to right.

NOTE: Make sure to use the holes marked "TT".

- 3.4 Set the unit into the recessed housing and align the center mark of the tube with the mark made on the front of the recessed housing.
- 3.5 Starting at the mechanism end, secure the mounting brackets to the recessed housing using the appropriate hardware. Lag bolts for wood housing, found in kit KA-0045, track screws/red anchors for concrete housing, found in kit KA-0044 and 3/8"-16 x 1.25" bolts (located in a heat sealed packaged located in the small kit box for APC, Inc. polymer box.) Repeat the process on the opposite side.

Tip: Usually the top of the mechanism brackets is mounted 1/2" from the top of the recessed housing. Use the rope angle to dictate how high to mount the mechanism and opposite end. The rope should come straight out of the back channel of the track into the pulley assembly, while maintaining a slight downward angle. This does not apply if using an APC, Inc. polymer box.

- 3.6 When the system is secured, make sure the unit is leveled and centered from front to back and left to right. Tighten all of the hardware on the mechanism with a 1/2" wrench. If system is mounted in an APC, Inc. polymer box, make sure to secure all of the 3/8"-16 with a 9/16" socket and ratchet.
- 3.7 Install two eyelets found in kit KA-0183 on the backside of the recessed housing at least 4' from each end of the track. Make sure the eyelets are in line with the pulleys on the mechanism end and opposite end mounting brackets.
- 3.8 Layout the lid bracket sleeves and space them out accordingly. The spacing should be 1' from the track on the outer lid bracket sleeves and the remaining lid bracket sleeves spaced equally.
- 3.9 Secure the lid bracket sleeves 1/4" down from the top of the recessed housing with supplied hardware. Lag bolts for wood housing located in kit KA-0045, track screws/red anchors for a concrete housing located in KA-0044 and if it is in an APC, Inc. polymer box, then insert the channel plates, and secure with (2) 3/8"-16 x 1.00" bolts.

Step 3.1

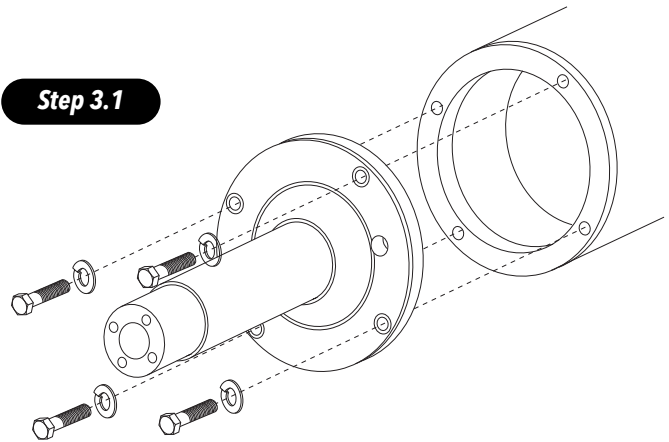

Step 3.2

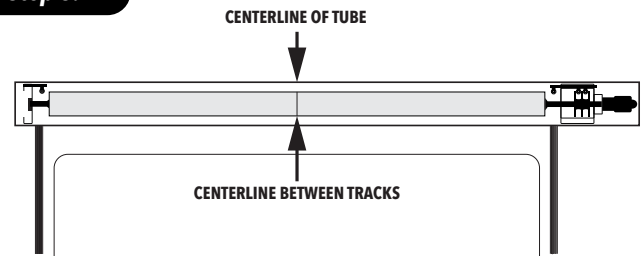

Step 3.7

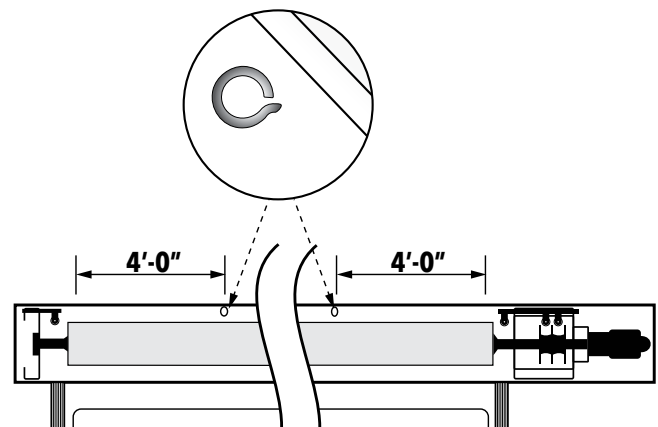

Step 3.8

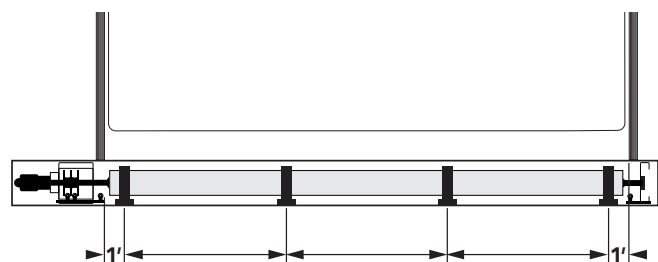

STEP 4: COVER INSTALLATION

INSTRUCTIONS

- 4.1 Lay the cover to the left side of the system and carefully remove the wrap. To allow the cover to unroll properly, be sure the label is facing the pool water.

NOTE: Make sure the matte side (smooth side) of the cover is facing upward showing the warning label.

- 4.2 Carefully unwind the ropes making sure they do not get tangled.
- 4.3 Starting on one side, with a 3' leader, snap the rope into the front channel (open) of the track and pull the rope down to the end pulley. Feed the rope around the end pulley, down the back channel (closed) of the track, while maintaining a 3' leader. Repeat for the other side.

TIP: Inserting the guide, found in kit KA-0178, will help keep the rope in the track channel and keep it from popping out.

- 4.4 Feed the opposite side rope through the opposite end pulley across the back of the box through the eyelets and through all 3 pulleys on the mechanism end and leave the extra length of rope lying on the deck.
- 4.5 Feed the motor side rope through the first 2 pulleys on the mechanism end and leave the extra length of rope lying on the deck.
- 4.6 Make sure the tracks on both sides are butted together at the splice and secure all of the track screws using a #3 bit.

NOTE: Make sure to not strip any of the screw heads, because this will leave a sharp burr.

- 4.7 Starting on the opposite side, gently pull on the rope so the rope tabs slide in the track channel.
- 4.8 Locate one of the rope sliders and (4) 5/16"-18 bolts in kit KA-0185, and insert the bolts through the rope slider and rope tabs. Make sure the tabs on the bottom of the rope slider slips into the track channel.
- 4.9 Locate one of the carriage plates and (4) 5/16" nuts and lock washers in kit KA-0185, install the carriage plate, squeezing the rope tabs between the rope slider and carriage plate using the lock washers and nuts to secure. **Do not over tighten bolts.**
- 4.10 Locate the lead edge bracket and carriage in kit KA-0185 and slide the small end of the bracket thru the slot in the carriage.
- 4.11 Locate the track slider and (2) 1/4"-20 flat head screws in kit KA-0185. Line up the holes of the track slider with the holes in the carriage and secure with the flat head screws. This will contain the lead edge bracket with the carriage assembly.

Step 4.3

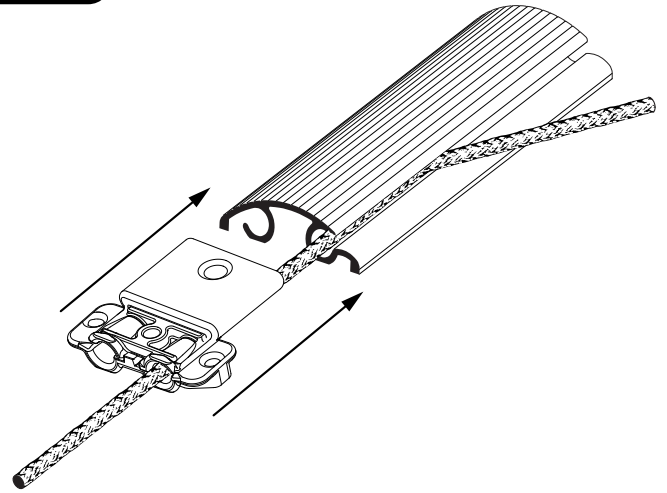

Step 4.4

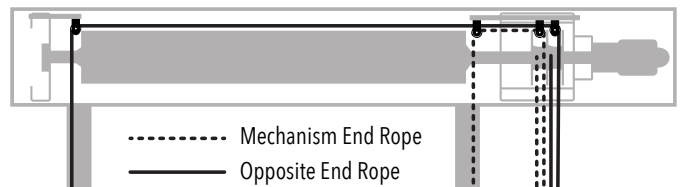

INSTRUCTIONS (CONTINUED)

- 4.12 Join the carriage assembly with the rope/carriage plate and secure together using (2) 1/4"-20 bolts in kit KA-0185. **Do not over tighten bolts.**
- 4.13 Locate the bottom half of the guide in kit KA-0178 and position the guide with the rope in one slot and the rope/webbing in the other slot. Slide the bottom half of the guide into the center channel of the track.
- 4.14 Locate the top half of the guide in kit KA-0178 and position it on the bottom half. Mark the center of the hole on the track.
- 4.15 Remove the guide and drill a hole at the mark on the track with a 5/16" drill bit.
- 4.16 Reinsert the bottom half and top half of the guide to the track and secure the halves together with the button head screw through the guide and flat head screw through the track.
- 4.17 Repeat steps 3-11 for the other side.

TIP: If your system is setup for a key switch, install the open magnet, found in kit KA-0184, into the front of the webbing on the motor side before installing the rope slider and carriage together. Pull the white strip off of the magnet and insert into the webbing. The magnets will travel approximately 1" past the sensor before the cover stops. Take this into consideration when installing the magnets.

- 4.18 Find the lead edge dowel in kit KA-0185 and insert into each end of the lead edge. Pre-drill an 11/64" hole through the lead edge and use the 1/2" screw to secure the dowels to the lead edge.
- 4.19 Starting on the motor side, slide the front edge of the cover into the lead edge channel. Hold the cover taut and slide the lead edge until it reaches the glider bracket. Insert the glider bracket into the middle slot of the lead edge dowel.
- 4.20 Adjust the cover corner in the lead edge and secure it with a 1/2" screw located in kit KA-0183.
- 4.21 With lead edge screw in place, starting at the opposite end pull cover slack and work towards the motor side. This will allow the slack to be even throughout the length of the lead edge.
- 4.22 Adjust the cover corner in the lead edge and secure it with a 1/2" screw found in kit KA-0183.
- 4.23 Repeat steps 3-11.

NOTE: Make sure the lead edge brackets are in the same slots of the lead edge dowel.

Step 4.17

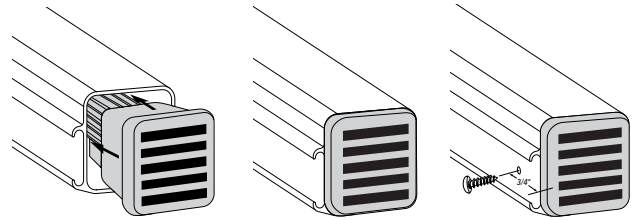

Step 4.18

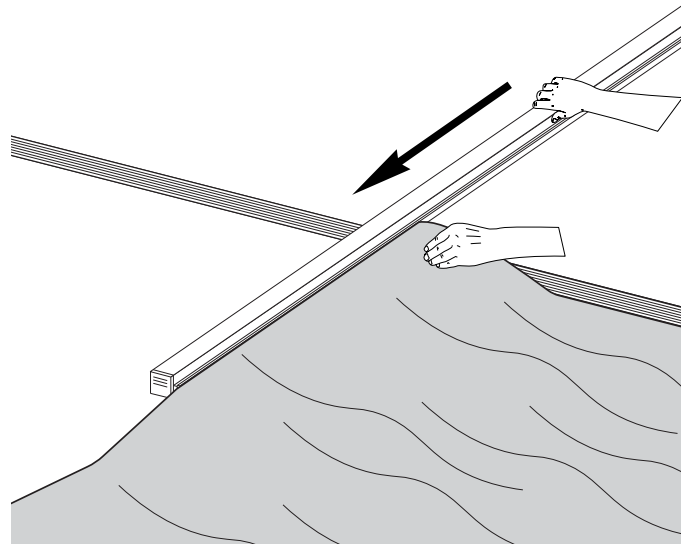

INSTRUCTIONS (CONTINUED)

- 4.24 Adjust the lead edge until it is parallel to the waters edge by gently pulling on the appropriate ropes. When satisfied with the position, cut the ropes evenly at 6' to 8' from the front edge of the recessed housing.
- 4.25 Tie knots at each end of the rope and insert the knot into the appropriate side of the rope reel. Use the controller to operate the system in the "close" direction to help guide the excess rope onto the rope reel evenly. **CAUTION: Keep hands clear so they do not get wrapped up in the rope reel.**
- 4.26 Continue to close the cover until the lead edge reaches the end of the pool. The cover should feed into the track smoothly and evenly. If the cover catches at the guide or if one side of the lead edge stops, release the controller and evaluate.
- 4.27 Attach the cover to the tube according to the diagram provided with 1/2" screws found in kit KA-0183. **Make sure to align the edge of the webbing with the edge of the tube.**
- 4.28 Use the controller to open the cover enough to take up the extra length of cover loosely around the tube. Cuff the edges of cover at each end. **If system is setup for a key switch, install the close magnet, found in kit KA-0184, in the tail end of the webbing on the motor side. Carefully cut a slit in the webbing 6" behind the guide. Pull the white strip off of the magnet and insert into the webbing. The magnets will travel approximately 1" past the sensor before the cover stops. Take this into consideration when installing the magnets.**
- 4.29 Run the cover 3 to 4 times open and close to ensure the magnets are set properly (if applicable) and the cover is running square to the pool. If not, follow the diagrams below on how to adjust the cover.
- 4.30 Find 4 hard stops, (8) #12 x 3.00" track screw and (8) red anchors in kit KA-0185. Position one hard stop near the far end of the track and the other one near the recessed housing at desired location for the lead edge bar to stop for both sides.
- 4.31 Lay the stop so the thicker end is flush with the front channel and the holes are at the center of the track. Mark the hole locations and drill the holes with a 1/4" drill bit.
- 4.32 Use a 1/4" masonry bit and drill 3" deep.
- 4.33 Insert each track screw into the red anchors by twisting the track screw into the red anchor.
- 4.34 Insert each track screw/anchor by tapping it through the hard stop and track so that the anchor is flush to the top of the concrete. Secure it with a #3 bit.

NOTE: Make sure that you do not strip any of the screw heads as this will leave a sharp burr.

Step 4.24

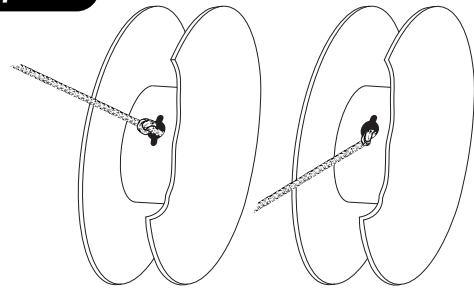

Step 4.26

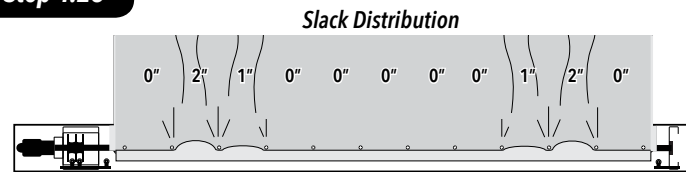

Step 4.29

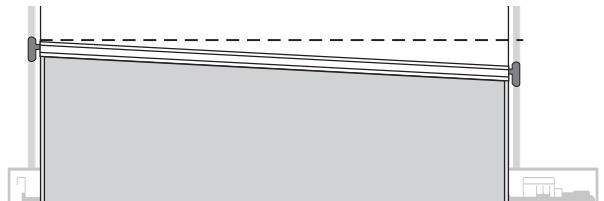

The **RIGHT** side rope need to be adjusted. Take all rope off the rope reel. **SHORTEN** the rope for this side by adjusting the location of the knot that is inserted into the rope reel approximately the same distance that the cover is crooked. Place rope back onto the reel and close cover.

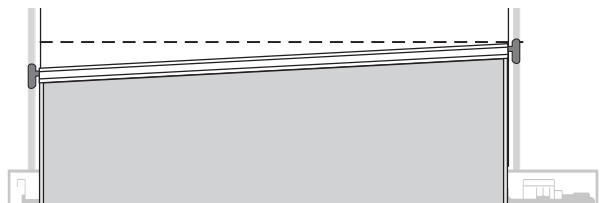

The **LEFT** side rope need to be adjusted. Take all rope off the rope reel. **SHORTEN** the rope for this side by adjusting the location of the knot that is inserted into the rope reel approximately the same distance that the cover is crooked. Place rope back onto the reel and close cover.

STEP 5: INSTALLING STANDARD MAIN LID

INSTRUCTIONS

- 5.1 Install the lid brackets into the lid bracket sleeves.
- 5.2 Slide the lid hinge onto the standard aluminum main lid.
- 5.3 Lay the lid assembly on top of the lid brackets centering the main lid between the tracks. Make sure there is equal distance on both sides of the track and that the lid assembly covers the front and back of the recessed housing. Cut any extra hinge with a hacksaw or circular saw making sure to leave approximately 1" of overhang on both ends of the housing. Make sure to file both ends of the hinge so there are no sharp edges or burrs.

NOTE: Cut the longer section of lid hinge if you have to use a 5' section of extra lid hinge.

- 5.4 With the main lid assembly set in place, drill 1/4" holes through the lid hinge so the holes line up with the wood box (if applicable) starting 3" to 4" from each end of the hinge and then space the other holes every 4'.
- 5.5 Secure the lid hinge with the appropriate supplied hardware:
Wood housing: Lid screws KA-0183
Concrete housing: Lid screws/red anchors in KA-0044 and KA-0183
- 5.6 Make sure the main lid is centered over the tracks and slide lid end on the motor side and mark it so it is even with the hinge. Cut the lid end with a jigsaw or circular saw and file both edges.

TIP: Cut the outside edge of the lid end to keep the manufactured cuts of the lid and lid end together.

- 5.7 Locate the correct lid triangle. Flip the lid end over and install the lid triangle by pre-drilling two 9/64" holes through the bottom of lid end and lid triangle.
- 5.8 Secure the lid triangle using 1/2" screws found in kit KA-0183.
- 5.9 Install the remaining portion of the lid end and slide it on the opposite side and mark it so it is even with the hinge. Cut the lid end with a jigsaw or circular saw and file both edges.

TIP: Cut the outside edge of the lid end to keep the manufactured cuts of the lid and lid end together.

NOTE: Double check to make sure the lid hinge, lid ends and main lid are filed thoroughly and do not have any sharp edges.

Make sure to put the cover pump on top of the cover when it is in the closed position and not being used.

Step 5.3



Step 5.4



Step 5.6

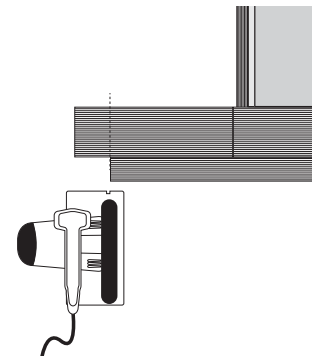

Step 5.9

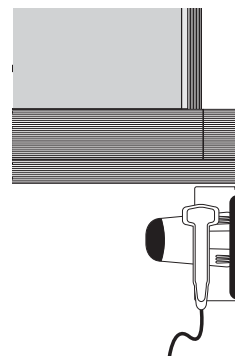

TECHNICAL SUPPORT

If you have any questions about these installation procedures, please contact Technical Support (800) 878-5789 Monday through Friday, 8 am - 5 pm EST.

Automatic Pool Covers_{Inc.}

(800) 878-5789 • automaticpoolcovers.com

TOOLS NEEDED

- | | | | |
|--|-----------------------------------|-------------------------------------|----------------------------|
| 1. Cordless drill | 2. Hammerdrill | 3. Phillips & Flat-head screwdriver | 4. Lighter |
| 5. Hammer | 6. Hacksaw (18 tooth blade) | 7. 12" Torpedo level | 8. 1/2" Round bastard file |
| 9. Wire strippers with cutters | 10. Circular Saw (aluminum blade) | 11. 25' & 100' tape measures | 12. 100' string |
| 13. Flat shovel | 14. Box knife | 15. Scissors | 16. Extension cords |
| 17. Drill bits: 1/4", 5/32", 11/64", #2 & #3 Phillips, 1/4" x 4" & 6" mason bit, 1/2" x 4" mason bit, 5/16" nut driver, 7/16" socket driver, & countersink | | | |
| 18. Wrenches/sockets: 7/16", 1/2", 9/16" | | | |

STEP 1: LAYING OUT THE TRACK

INSTRUCTIONS

Step 1.1 Verify the track space that was ordered for your system. This can be found on all of the packing slips. **Ex. T/W [FT] 20.25 T/L [FT] 43**
The mechanism, main tube, lead edge and cover are based off of the ordered track space.

Step 1.2 Determine **TRACK LENGTH**: 2. Measure 1' past the waters edge to the opposite end of the pool and add 2' for overlap.

Step 1.3 Layout the tracks on one side of the pool. Insert a track splice, found in kit KA-0178 or KA-0182. Cut off any excess track with a hacksaw or circular saw at the recessed housing end. **Make sure all ends of the tracks are filed and countersunk.**

HINT: Do not cut the track where two tracks will meet. It is best to keep the manufactured cuts at the splice.

NOTE: If the track length is over 44', splice a third piece of track per side. Never install a piece of track less than 5'. If needed, cut one of the full pieces of track down to accommodate the extra.

Step 1.4 Drill new holes 3" from the splice end if the manufactured holes are cut off. Use a 1/4" drill bit and countersink. File and countersink all ends of the tracks to make sure there are no sharp edges for the rope or webbing to rub on.

Step 1.5 Lay out tracks on both sides and measure the distance between the tracks. **This is the EDGE TO EDGE measurement. Add 1" for your TRACK WIDTH.**

Step 1.6 Place the tracks equal distance from each side of the pool. The track space needs to be the same at the recessed housing, the splice and the opposite end to make sure they are parallel.

Step 1.7 Take a diagonal measurement and adjust accordingly.

Foot Decimal to Inch Conversion

Decimal	.08	.17	.25	.33	.42	.50	.58	.67	.75	.83	.92
Inches	1	2	3	4	5	6	7	8	9	10	11

Step 1.2 & 1.5

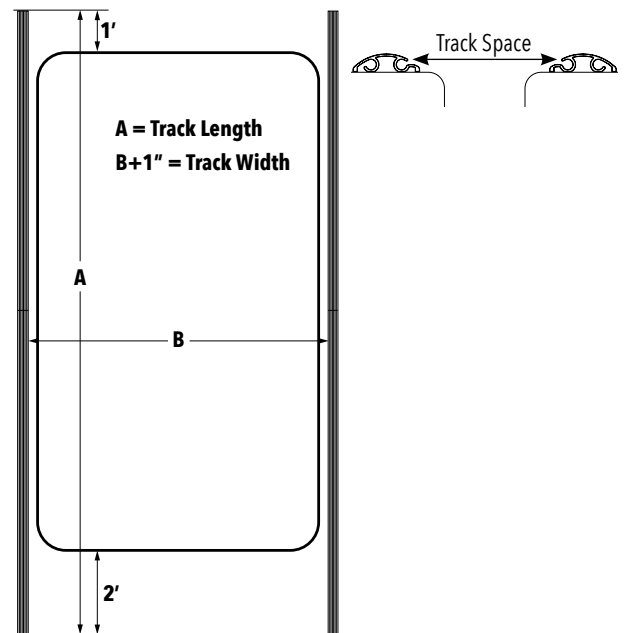

Step 1.3

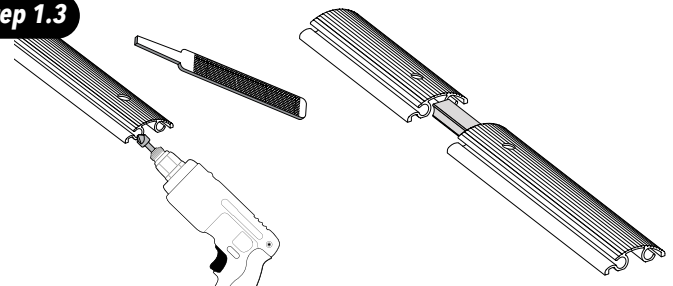

STEP 2: INSTALLING THE TRACK

INSTRUCTIONS

Step 2.1 Locate kit KA-0006 and insert each track screw into the red anchors by twisting the track screw into the red anchor.

Step 2.2 Starting at the unit end, position a cedar shim under the track. Use a hammer drill with a 1/4" masonry bit and drill through the closest hole 3" deep.

Step 2.3 Install track screws from kit KA-0183 and anchors found in kit KA-0006 (located in the small kit box) by tapping it through the track into the deck so that the screw is 1/2" above the track. **Do not tighten down the track screw at this time.**

Step 2.4 Make sure the track splice is snug together and walk down to the opposite end and drill the last hole 3" deep.

Step 2.5 Install one of the track screws and anchors by tapping it through the track into the deck so that the anchor is flush to the top of the concrete. **Do not tighten down the track screw at this time.**

HINT: Stand on the track while drilling to prevent the track from shifting.

Step 2.6 To keep the track straight, run a string down the track from one end to the other by using the track screws installed, allowing the rest of the holes in the tracks to line up.

Step 2.7 Drilling the remaining holes and insert the track screws and anchors **but do not tighten down.**

Step 2.8 Repeat these steps for the opposite side.

NOTE: An angle drill may need to be used to drill holes under a slide.

Step 2.9 When all the tracks are drilled and loosely secured with the track screws and anchors, locate the pulley casting assembly in kit KA-0178 or KA-0182 (located in the small kit box) and insert the pulley casting assembly in the far end of the pool.

Step 2.10 Tap the top of the pulley casting to create a mark in the deck, remove the pulley casting and drill a 1/2" diameter hole 1/2" deep on the mark to recess the pulley nut into the deck.

Step 2.11 Repeat the steps 9-10 for the opposite side.

Step 2.2

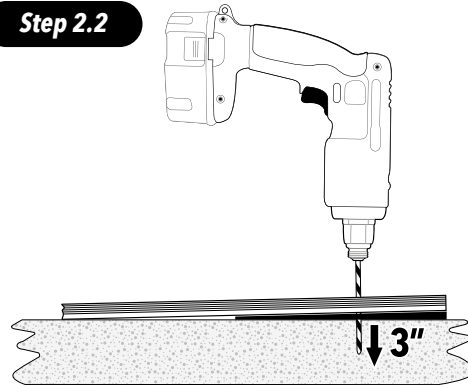

Step 2.3

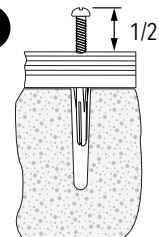

Step 2.4



Step 2.5

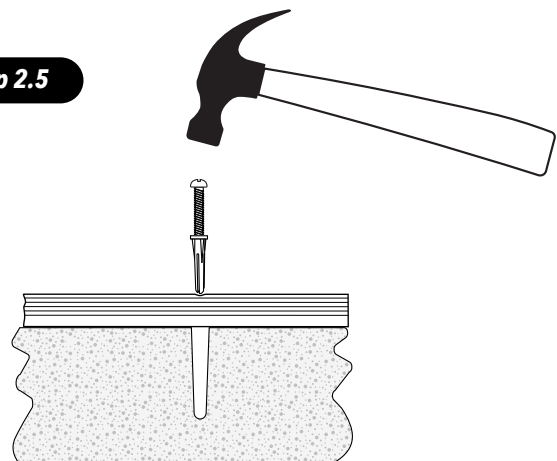

Step 2.9



STEP 3: INSTALLING THE AUTOGUARD

INSTRUCTIONS

Install the Motor and Control panel following the Wiring Diagram enclosed with Motor

Step 3.1 Attach the main tube to the mechanism end and opposite end castings with (4) 5/16" - 18 x 0.75" bolts and lock washers found in kit KA-0183 using a 1/2" wrench.

Step 3.2 Line up the assembled unit to the tracks.

Step 3.3 Starting on the mechanism end, measure 12" from the center of the bolt on the pulley casting to the end of the track.

Step 3.4 On the opposite end, measure 12" from the center of the bolt on the pulley casting to the end of the track.

Step 3.5 Measure the distance between the two tracks and find the halfway point and make a mark on the deck surface.

Step 3.6 Align the center mark of the tube to the center mark made on the deck surface. Check the alignment of the rope.

Step 3.7 On the opposite side, drill 4 holes through the mounting brackets into the deck by using a 1/4" masonry bit.

Step 3.8 Locate the heat seal package of red anchors and #12 x 1.75" screws in kit KA-0432 and insert the screw into the red anchor, by twisting the screw into the red anchor.

Step 3.9 Tap in the screw/anchor through the mechanism bracket into the deck until the screw is 1/2" above the track. Tighten using a #3 bit.

Step 3.10 Mark the mechanism or holes

Step 3.11 On the mechanism end, remove the 2 coupler bolts from motor and main shaft by using a 9/16" socket with a ratchet and extension.

Step 3.12 After removing the coupler, lift up the end casting and rope reel assembly.

Step 3.1

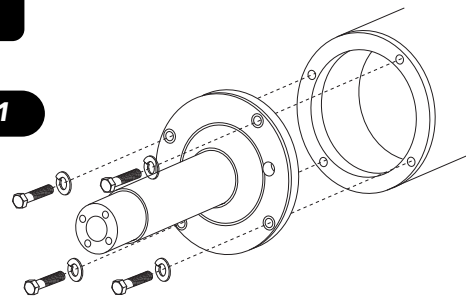

Step 3.3

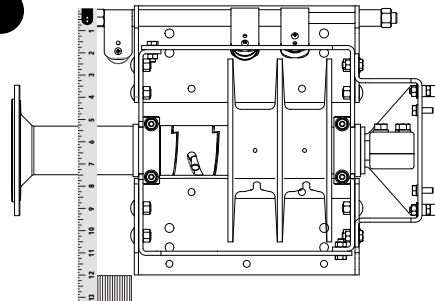

Step 3.4

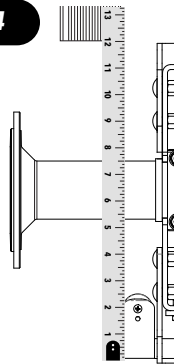

Step 3.6

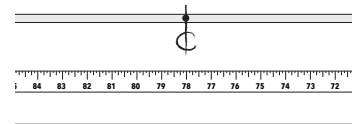

Step 3.7

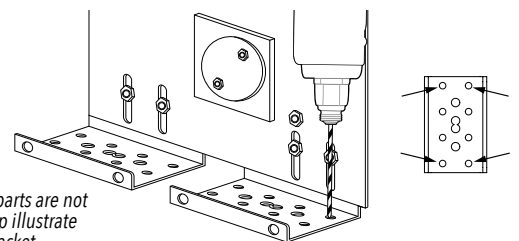

Note: Some parts are not shown to help illustrate mounting bracket.

Step 3.11

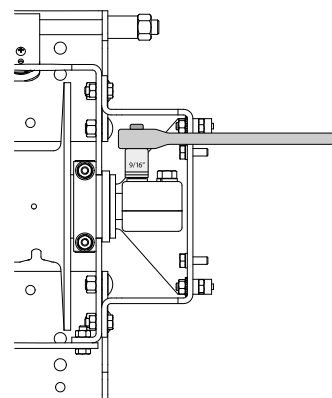

INSTRUCTIONS (CONTINUED)

Step 3.13 Double check the distance from the pulley bolt to the track to make sure it is 12". Drill 6 holes through the mounting brackets into the deck by using a 1/4" masonry bit.

Step 3.14 Use the same screw/anchor as the opposite side and tap in the screw/anchor through the mechanism bracket into the deck until the anchor is 1/2" above plate with the deck and tighten down using a #3 bit.

Step 3.15 On the opposite end, raise the unit frame approximately 2" (depending on deck crown or fall) and level front to back and side to side. Tighten down the hardware using a 1/2" wrench.

Step 3.16 Repeat for the mechanism end.

Step 3.17 Lift up on the end casting and reinstall the rope reel assembly and lower back into the mechanism frame.

Step 3.18 Reassemble the motor coupler and bolts back to the motor and main shaft.

Step 3.19 With a chalk line or a string, mark the deck from the opposite end pulley casting to the motor end pulley casting. Drill 2 holes with a 9/16" masonry bit 4' from each pulley casting.

Step 3.20 Locate the 2 eyelets in kit KA-0183 and insert them into the red anchors. Tap in the eyelet/anchor in the holes until the bottom of the eyelet is flush with the deck surface.

Step 3.13

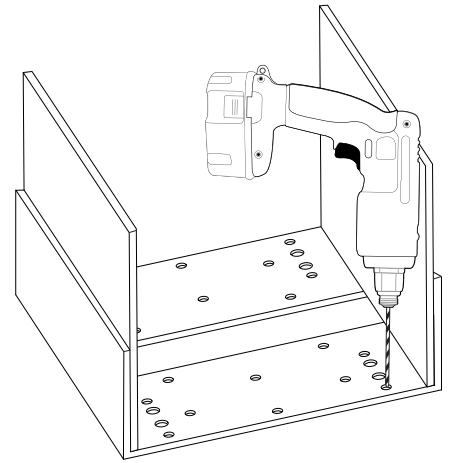

Step 3.15

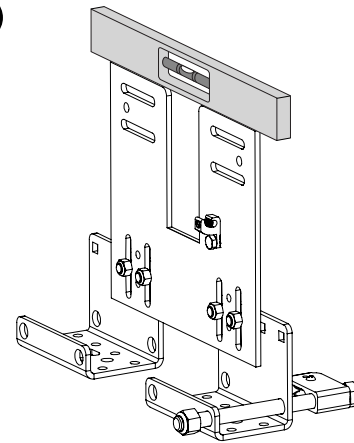

Step 3.19

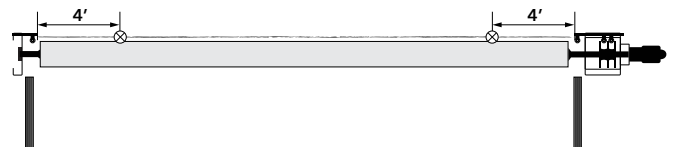

Step 3.20

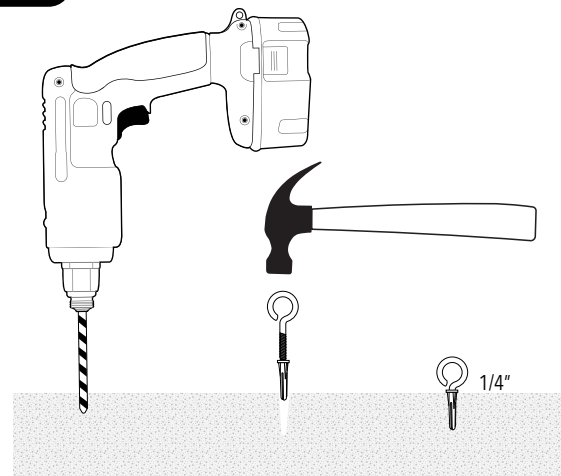

STEP 4: INSTALLING THE COVER

INSTRUCTIONS

Step 4.1 Lay the cover to the left side of the system and carefully remove the wrap. To allow the cover to unroll properly, be sure the label is facing the pool water.

NOTE: Make sure the matte side (smooth side) of the cover is facing upward showing the warning label.

Step 4.2 Carefully unwind the ropes making sure they do not get tangled.

Pro's Tip Inserting the guide, located in kit KA-0178 or KA-0182, will help the rope stay in the track channel and keep it from popping out.

Step 4.3 Starting on one side, with a 3' leader, snap the rope into the front channel (open) of the track and pull the rope down to the end pulley. Feed the rope around the end pulley, down the back channel (closed) of the track, while maintaining a 3' leader. Repeat for the other side.

Step 4.4 Route the opposite side rope through the opposite end pulley across the back of the unit through the eyelets and through all 3 pulleys on the mechanism end and leave the extra length of rope lying on the deck.

Step 4.5 Feed the motor side rope through the first 2 pulleys on the mechanism end and leave the extra length of rope lying on the deck.

Step 4.6 Make sure the tracks on both sides are butted together at the splice and secure all of the track screws using a #3 bit.

NOTE: Make sure to not strip any of the screw heads, because this will leave a sharp burr.

Step 4.7 Starting on the opposite side, gently pull on the rope so the rope tabs slide in the track channel.

For more detailed instructions for assembling the carriage assembly, refer to illustrated instructions sheet included with the kit.

Step 4.8 Locate one of the rope sliders and (4) 5/16" - 18 bolts in kit KA-0185, and insert the bolts through the rope slider and rope tabs. Make sure the tabs on the bottom of the rope slider slips into the track channel.

Step 4.9 Locate one of the carriage plates and (4) 5/16" nuts and lock washers in kit KA-0185, install the carriage plate, squeezing the rope tabs in between the rope slider and carriage plate using the lock washers and nuts to secure. **Do not over tighten bolts.**

Step 4.10 Locate the lead edge bracket and carriage in kit KA-0185 and slide the small end of the bracket through the slot in the carriage.

Step 4.3

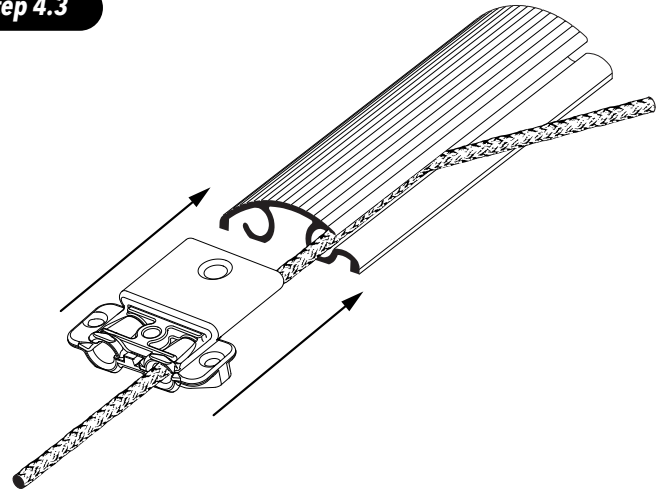

Step 4.4

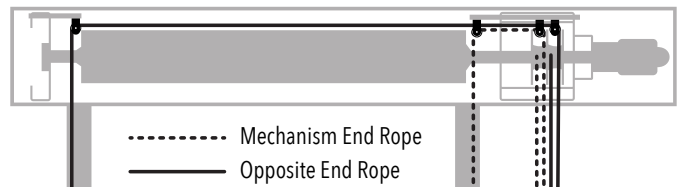

INSTRUCTIONS (CONTINUED)

Step 4.11 Locate the track slider and (2) 1/4"-20 flat head screws in kit KA-0185. Line up the holes of the track slider with the holes in the carriage and secure with the flat head screws. This will contain the lead edge bracket with the carriage assembly.

Step 4.12 Join the carriage assembly with the rope/carriage plate and secure together using (2) 1/4"-20 bolts in kit KA-0185. **Do not over tighten bolts.**

Step 4.13 Locate the bottom half of the guide in kit KA-0178 or KA-0182 and position the guide with the rope in one slot and the rope/webbing in the other slot. Slide the bottom half of the guide into the center channel of the track.

Step 4.14 Locate the top half of the guide in kit KA-0178 or KA-0182 and position it on the bottom half. Mark the center of the hole on the track.

Step 4.15 Remove the guide and drill a hole at the mark on the track with a 5/16" drill bit.

Step 4.16 Reinsert the bottom half and top half of the guide to the track and secure the halves together with the button head screw through the guide and flat head screw through the track.

Pro's Tip If your system is setup for a key switch, install the magnet, found in kit KA-0184, into the front of the webbing on the motor side before installing the rope slider and carriage together. Pull the white strip off of the magnet and insert into the webbing. The magnets will travel approximately 1" past the sensor before the cover stops. Take this into consideration when installing the magnets.

Step 4.17 Find the lead edge dowel in kit KA-0185 and insert into each end of the lead edge. Pre-drill an 11/64" hole through the lead edge and use the 1/2" screw to secure the dowels to the lead edge.

Step 4.18 Starting on the motor side, slide the front edge of the cover into the lead edge channel. Hold the cover taut and slide the lead edge until it reaches the glider bracket. Insert the glider bracket into the middle slot of the lead edge dowel.

Step 4.19 Adjust the cover corner in the lead edge and secure it with a 1/2" screw located in kit KA-0183.

Step 4.20 With lead edge screw in place, starting at the opposite end pull cover slack and work towards the motor side. This will allow the slack to be even throughout the length of the lead edge.

Step 4.21 Adjust the cover corner in the lead edge and secure it with a 1/2" screw found in kit KA-0183.

Step 4.17

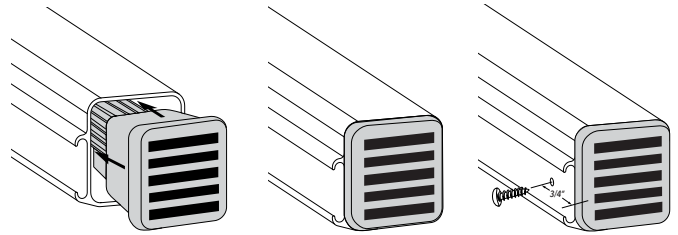

Step 4.18

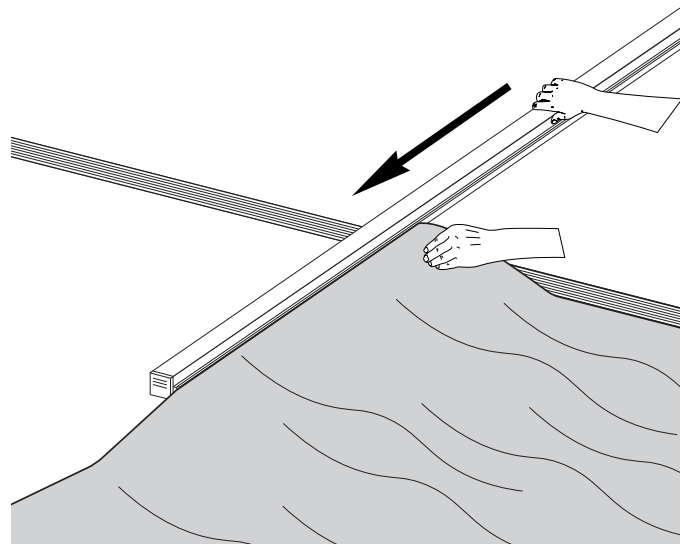

INSTRUCTIONS (CONTINUED)

Step 4.22 Repeat steps 11-16.

NOTE: Make sure the lead edge brackets are in the same slots of the lead edge dowel.

Step 4.23 Adjust the lead edge until it is parallel to the waters edge by gently pulling on the appropriate ropes. When satisfied with the position, cut the ropes evenly at 6' to 8' from the front edge of the mechanism.

Step 4.24 Tie knots at each end of the rope and insert them into the appropriate side of the rope reel. Use the controller to operate the system in the "close" direction to help guide the excess rope onto the rope reel evenly. **CAUTION: Be careful and make sure to remove your hands so they do not get wrapped up in the rope reel.**

Step 4.25 Continue to close the cover until the lead edge reaches the end of the pool. The cover should feed into the track smoothly and evenly. If the cover catches at the guide or if one side of the lead edge stops, release the controller and evaluate. If the system is setup for a key switch, install the close magnet, found in kit KA-0184, in the tail end of the webbing on the motor side. Carefully cut a slit in the webbing 6" behind the guide. Pull the white strip off of the magnet and insert into the webbing. The magnets will travel approximately 1" past the sensor before the cover stops. Take this into consideration when installing the magnets.

Step 4.26 Attach the cover to the tube according to the diagram provided with 1/2" screws found in kit KA 0183. **Make sure cover rolls under the tube and to align the edge of the webbing with the edge of the tube.**

Step 4.27 Use the controller to open the cover enough to take up the extra length of cover loosely around the tube. Cuff the edges of cover at each end.

Step 4.28 Open and close the cover 3 to 4 times to make sure the magnets are set properly (if applicable) and the cover is running square to the pool. If not, follow the diagrams on how to adjust the cover.

Step 4.29 Locate 4 hard stops, (8) #12 x 3.00" track screw and 8 red anchors in kit KA-0185 (located in the small kit box.) Position one hard stop near the far end of the track and the other one near the recessed housing where you would like the lead edge bar to stop for both sides.

Step 4.30 Lay the stop so the thicker end is flush with the front channel and the holes are at the center of the track. Mark the hole locations and drill the holes with a 1/4" drill bit.

Step 4.31 Use a 1/4" masonry bit and drill 3" deep.

Step 4.32 Insert each track screw/anchor by tapping it through the track so that the anchor is 1/2" above the track.

NOTE: Make sure not to strip any of the screw heads as this will leave a sharp burr.

Step 4.26

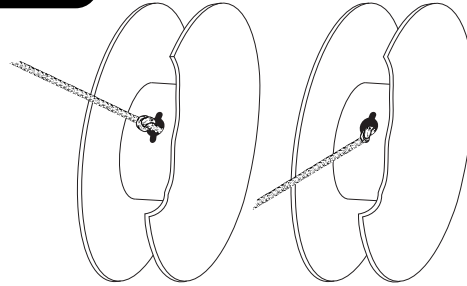

Step 4.26

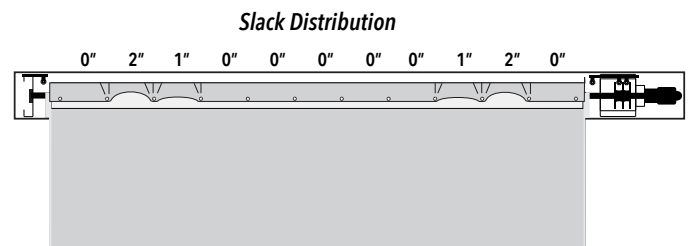

Step 4.28

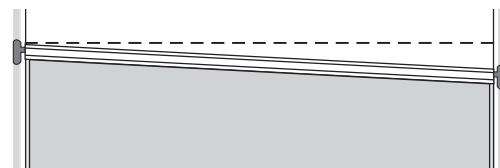

In this illustration, the **RIGHT** side rope need to be adjusted. Take all rope off the rope reel. **SHORTEN** the rope for this side by adjusting the location of the knot that is inserted into the rope reel approximately the same distance that the cover is crooked. Place rope back onto the reel and close cover.

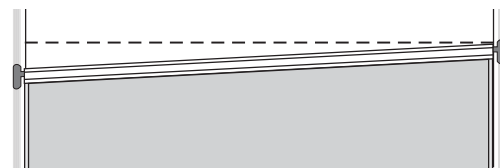

In this illustration, the **LEFT** side rope need to be adjusted. Take all rope off the rope reel. **SHORTEN** the rope for this side by adjusting the location of the knot that is inserted into the rope reel approximately the same distance that the cover is crooked. Place rope back onto the reel and close cover.

STEP 5: INSTALLING BENCH FRAME ASSEMBLY

INSTRUCTIONS

Step 5.1 On the opposite end, find the bench bracket base located in the small kit box and position the bracket side ways (the back of the upright should be facing on the outside) with the 7" pulley bolt center of the up right on the base.

Step 5.2 On the mechanism end, center the base next to the motor handle and measure 2.5" from the upright to the handle. The back of the upright should be facing away from the unit.

Step 5.3 Use a 1/4" masonry bit and drill through the holes of each base 2.5" deep.

Step 5.4 Find the 1/4" wedge anchors and 1.75" screws and red anchors in kit KA-0028. Insert each screw into the red anchor.

Step 5.5 Tap in the screw/anchor into the front holes of the base and 1/4" wedge anchor in the back of the base.

Step 5.6 Tighten down the hardware using a #3 bit for the screws and a 7/16" socket with ratchet and extension for the nuts on the wedge anchors.

Step 5.7 Layout and evenly space the remaining bases between the installed bases.

NOTE: If the track spacing is 20'5" or wider, aluminum angle pieces are required to be attached on the back of the bench arms. Locate the pieces and position on the back of the bench arm 9" away on the motor end where the angle ends. This is the position the base will be mounted. Be sure to use the bench arm that has the wider front and back flange to secure the angle.

Step 5.8 Run a string from each end bases to align the remaining bases, drill and secure in same manner as the two end bases.

Step 5.9 After all of the wedge anchors and screws are installed, locate the bench bracket arms and slide them onto the base to check for level front to back and side to side.

Step 5.1

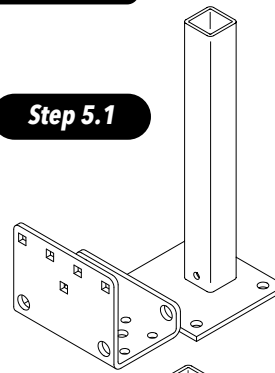

Step 5.2

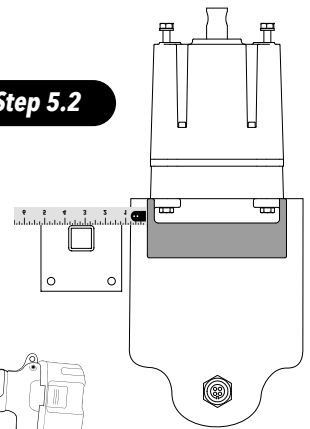

Step 5.3

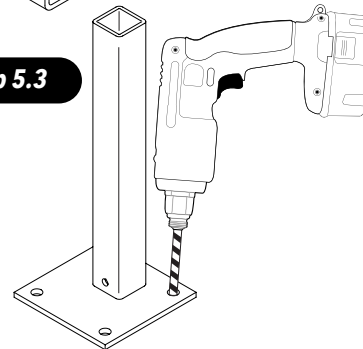

Step 5.7

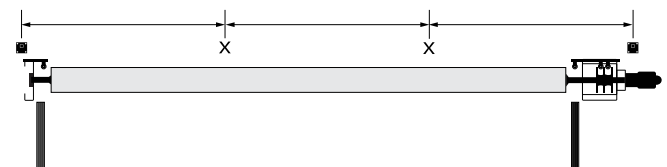

NOTE

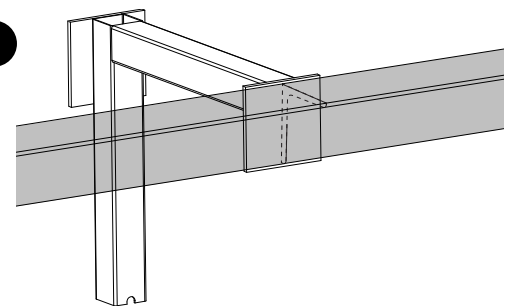

Step 5.8

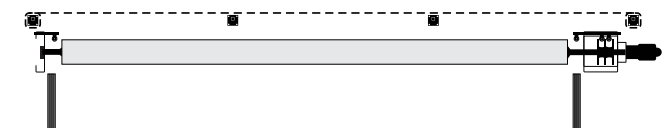

Step 5.9

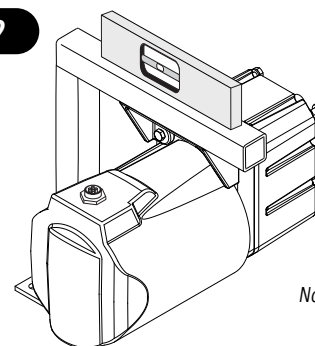

Note: Some parts are not shown to give unobstructed view.

INSTRUCTIONS (CONTINUED)

Step 5.10 Locate the angle aluminum and lay one piece at the front and the other piece at the back on top of the bench arms.

Step 5.11 Square up both ends and then measure 3" from the bracket on the opposite end and 9" on the motor end.

Step 5.12 Mark both angle aluminum pieces directly center of the bracket. Position the holes 3/4" away from the top of the angle.

Step 5.13 Drill a hole through the marked spot on the angle aluminum pieces using a 1/4" drill bit. Drill identical hole on opposite angle aluminum piece.

Step 5.14 Starting on the back side, attach the angle aluminum to the bench bracket with self taps found in kit KA-0028. Be sure the angle aluminum is 1/8" higher than the top of the bench bracket. Continue installing self taps until the angle is secured to the back of each bracket.

Step 5.15 Square the front piece of angle aluminum and secure as done with the back piece. Make sure the front piece is level with the back piece.

Step 5.16 Starting at the center most bench bracket, raise it up to 15" and secure with 2 self taps.

Step 5.17 Level all other brackets off of the center. Aluminum angle MUST be level.

Step 5.10

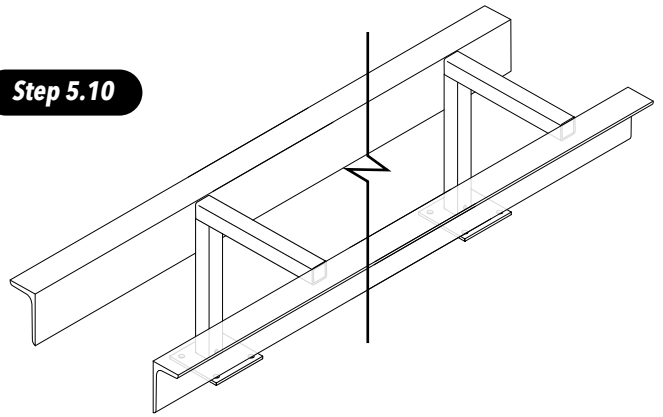

Step 5.11

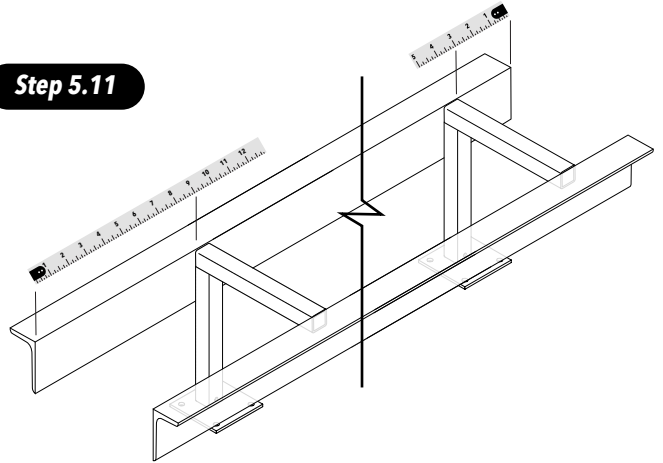

Step 5.12

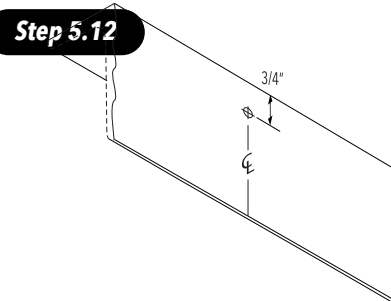

Step 5.14

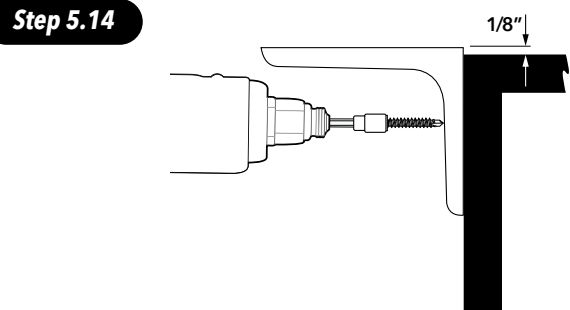

Step 5.15

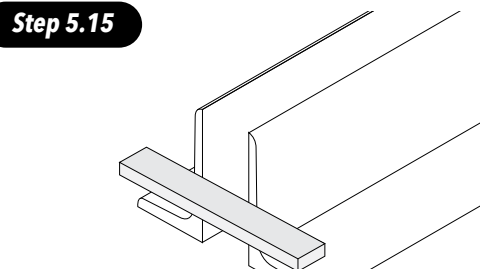

STEP 6: INSTALLING THE VINYL BENCH

INSTRUCTIONS

IMPORTANT: Be careful not to scratch the face of the vinyl pieces.

Step 6.1 Locate the front pieces of the vinyl bench and lay them out face down on top of the bench frame. Match up the like number sections and slide each one together and assemble them using two 1/2" screws found in a closed envelop taped to one of the vinyl sections per section.

HINT: Make sure to put the motor side and opposite side on the appropriate side.

Step 6.2 After all of the sections are assembled, orientate the entire section so the opening on the bottom of the vinyl is facing down. **Make sure that it is spaced equally over the tracks.**

Step 6.3 Push the vinyl up to the underside of the angled aluminum and drill through the vinyl and angled aluminum 1/2" down using a 1/4" drill bit.

Step 6.4 Locate the 1/4-20 x 2.00" bolt, washer and nut in kit KA-0030 and secure the panels making sure the nut is on the inside.

Step 6.5 Locate the back pieces of the vinyl bench and lay them out face down on top of the bench frame. Match up the like number sections and slide each one together and assemble them using two 1/2" screws per section.

NOTE: Make sure to square each end up from the back section to the front section.

Step 6.6 Repeat steps 2-4.

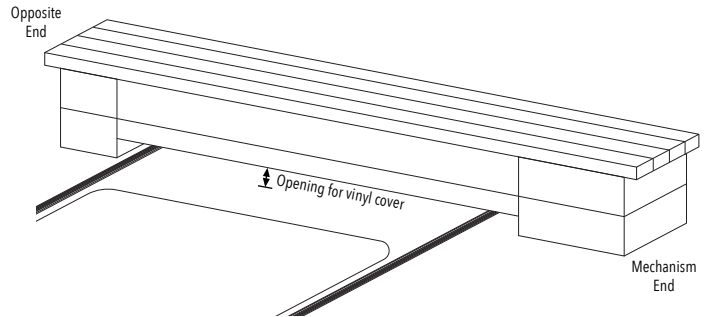

Step 6.1

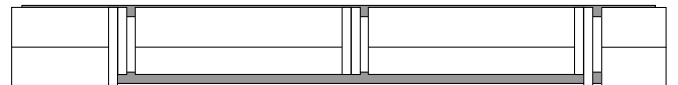

Step 6.2

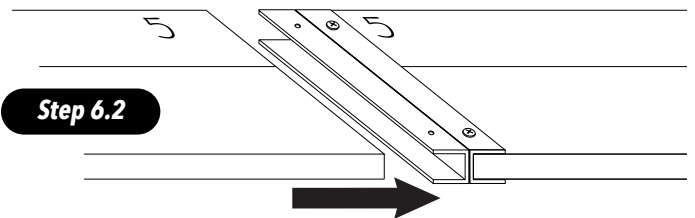

Step 6.2a

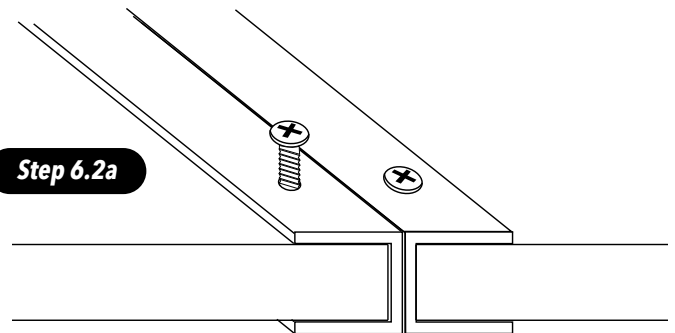

Step 6.3

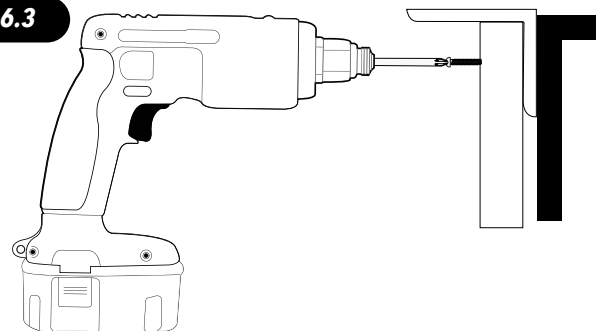

INSTRUCTIONS (CONTINUED)

Step 6.7 Slide the vinyl end pieces on and attach to the front and back sections using a total of (4) 1/2" screws per section. **Be sure corners are flush.**

Step 6.8 Lay out the top of the vinyl bench and evenly space over the top of the frame side to side and front to back and slide each panel together.

NOTE: Make sure to put the motor side and opposite side on the appropriate side.

Step 6.9 Looking up at the underside of the bench top, locate a cross member in each top panel and use a 11/64" drill bit to drill through the angled aluminum at the center of the cross member for the front and back. Install 2 - 4 screws per section.

Step 6.10 Locate the 1" screw in kit KA-0030 to secure the top to the angled aluminum.

NOTE: Make sure to put the cover pump on top of the cover when it is in the closed position and not being used.

Step 6.7a

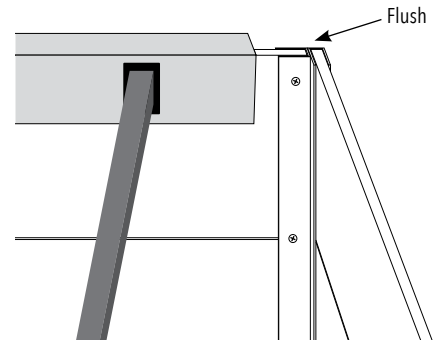

Step 6.7b

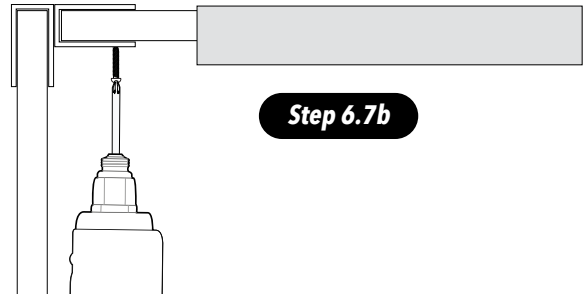

Step 6.8

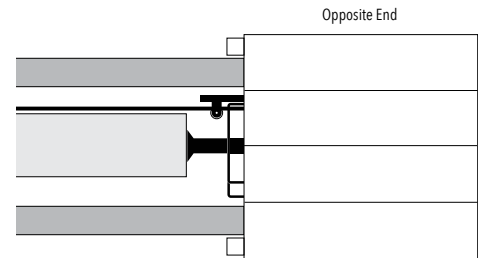

Step 6.9

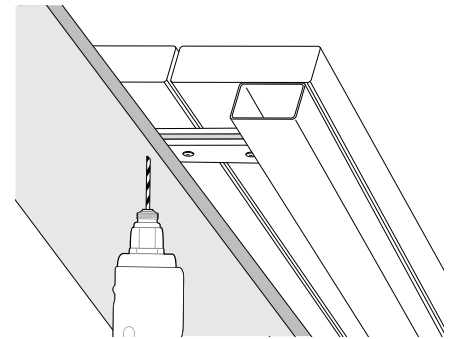

Step 6.10

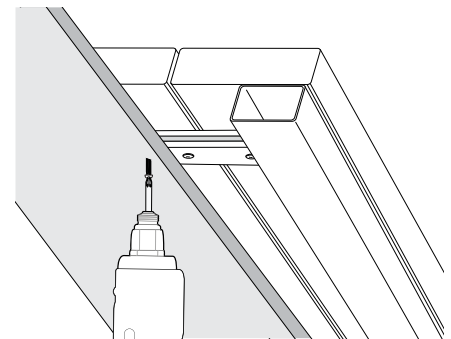

TECHNICAL SUPPORT

If you have any questions about these installation procedures, please contact Technical Support (800) 878-5789 Monday through Friday, 8 am - 5 pm EST.

Automatic Pool Covers^{Inc.}

(800) 878-5789 • automaticpoolcovers.com

TOOLS NEEDED

- | | | | |
|-----------------------------------|--|------------------------------|-----------------------------|
| 1. Cordless drill | 2. Hammer drill | 3. Phillips screwdriver | 4. Hammer |
| 5. Hacksaw with 18 tooth blade | 6. 1/2" Round bastard file | 7. Saw (with aluminum blade) | 8. 25' & 100' tape measures |
| 9. Box knife | 10. Scissors | 11. Extension cords | 12. Lighter |
| 13. Wrenches/sockets: 1/2", 9/16" | 14. Bits: 1/4", #2 & #3 Phillips, countersink, 1/4"x 6" & 3/8"x 6" mason | | |

STEP 1: TOP TRACK INSTALLATION

INSTRUCTIONS

Step 1.1 Verify the track space that was ordered for your system. This can be found on all of the packing slips. **Ex. T/W [FT] 20.25 T/L [FT] 43**
The mechanism, main tube, lead edge and cover are based off the ordered track space.

Step 1.2 Determine **TRACK LENGTH**: Measure 1' past the waters edge to the opposite end of the pool and add 2' for overlap.

Step 1.3 Layout the tracks on one side of the pool, insert a track splice, found in kit KA 0150, and cut off any excess track with a hacksaw or circular saw at the recessed housing end. **Make sure to file and countersink all ends of the tracks.**

HINT: Do not cut the track where the splices will meet. It is best to keep the manufactured cuts at the splice.

Step 1.4 If the manufactured holes are cut off after cutting, drill new holes 3" from the splice end. Use a 1/4" drill bit and countersink. File and countersink all ends of the tracks to make sure there are no sharp edges for the rope or webbing to rub on.

Step 1.5 Align the tracks on both sides and measure the distance between the tracks. **This is the edge to edge measurement. Add 1" for the track width.**

Step 1.6 Place the tracks equal distance from each side of the pool. The track space needs to be the same at the mechanism end, the splice and the opposite end to make sure they are parallel.

Step 1.7 To insure the layout is square, take a diagonal measurement and adjust accordingly.

Foot Decimal to Inch Conversion

Decimal	.08	.17	.25	.33	.42	.50	.58	.67	.75	.83	.92
Inches	1	2	3	4	5	6	7	8	9	10	11

Step 1.7

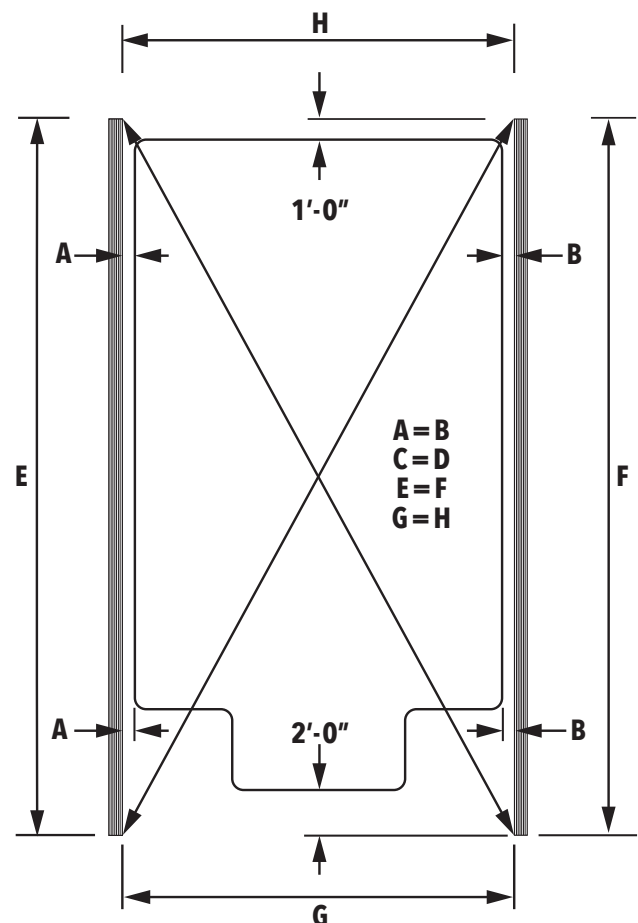

STEP 2: TOP TRACK INSTALLATION

INSTRUCTIONS

Step 2.1 Locate kit KA 0006 and insert each track screw into the red anchors by twisting the track screw into the red anchor.

Step 2.2 Starting at the unit end, position a cedar shim under the track. Use a hammer drill with a 1/4" masonry bit and drill through the closest hole 3" deep.

Step 2.3 Install track screws and anchors by tapping it through the track into the deck so that the anchor is flush to the top of the concrete. **Do not tighten down the track screw at this time.**

Step 2.4 Make sure the track splice is snug together and walk down to the opposite end and drill the last hole 3" deep.

Step 2.5 Install one of the track screws and anchors by tapping it through the track into the deck so that the anchor is flush to the top of the concrete. **Do not tighten down the track screw at this time.**

HINT: Stand on the track while drilling to prevent the track from shifting.

Step 2.6 To keep the track straight, run a string down the track from one end to the other by using the track screws installed, allowing the rest of the holes in the tracks to line up.

Step 2.7 Drill the remaining holes and insert the track screws and anchors. **Do not tighten down the track screw at this time.**

Step 2.8 Repeat Steps 2.1 - 2.7 on the opposite side.

NOTE: An angle drill may be necessary to drill holes under a slide.

Step 2.9 When all the tracks are drilled and loosely secured with the track screws and anchors, locate the pulley casting assembly in kit KA 0150 and insert the pulley casting assembly in the far end of the pool.

Step 2.10 Tap the top of the pulley casting to create a mark in the deck, remove the pulley casting and drill a 1/2" diameter hole 1/2" deep on the mark to recess the pulley nut into the deck.

Step 2.11 Repeat the steps 2.9 - 2.10 for the opposite side.

Step 2.1

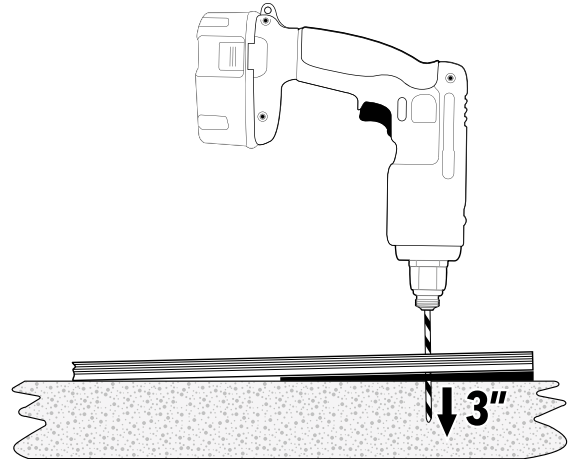

Step 2.4



Step 2.5

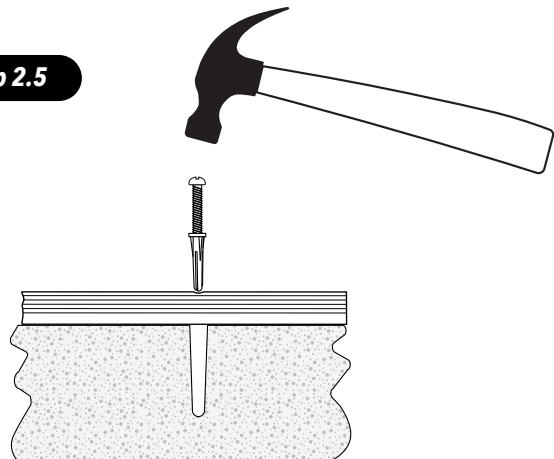

Step 2.10



STEP 3: INSTALLING THE COVER

INSTRUCTIONS

Step 3.1 Move the cover to the left side of the system. To allow the cover to unroll properly, be sure the label facing the pool water. Carefully remove the wrap.

NOTE: Make sure the matte side (smooth side) of the cover is facing upward showing the warning label.

Step 3.2 Starting on one side, insert the webbing at the front of the cover about 12".

Step 3.3 Locate the bottom half of the guide in kit KA 0150 and position the guide with the rope in one slot and the rope/webbing in the other slot. Slide the bottom half of the guide into the center channel of the track.

Step 3.4 Locate the top half of the guide in kit KA 0150 and position it on the bottom half. Mark the center of the hole on the track.

Step 3.5 Remove the guide and drill a hole where the mark is on the track with a 5/16" drill bit.

Step 3.6 Reinsert the bottom half and top half of the guide to the track and secure the halves together with the button head screw through the guide and flat head screw through the track.

Step 3.7 Repeat Steps 3.2 - 3.6 on the opposite side.

Step 3.8 Locate the lead edge and slide the front edge of the cover into the lead edge channel. Hold the cover taught and slide the lead edge until it reaches the other end.

Step 3.2

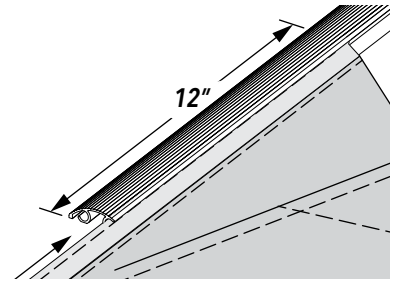

Step 3.3

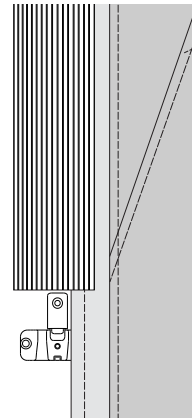

Step 3.4

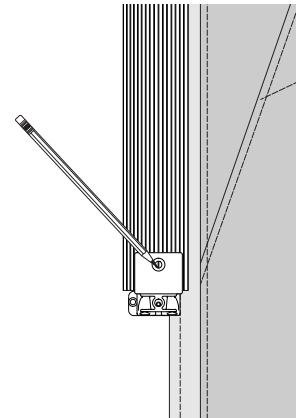

Step 3.5

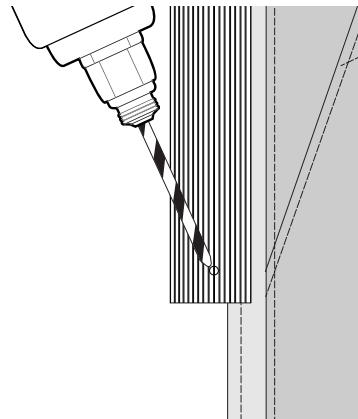

Step 3.6

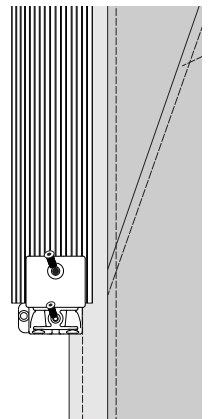

Step 3.8

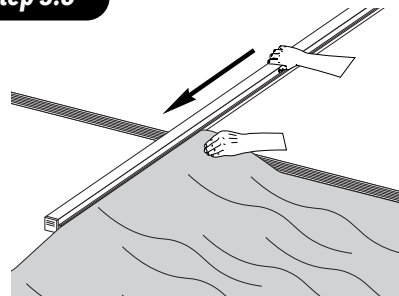

INSTRUCTIONS (CONTINUED)

Step 3.9 Locate the 2 long sections of ropes with handles in the small kit box. Insert the end of the rope through the pre-drilled hole in the front of the lead edge on both sides.

Step 3.10 Tie a knot at the end of the rope and pull until it bottoms against the inside of the lead edge.

Step 3.11 Locate the wheel assembly. Flip the lead edge over and install the wheel assembly on both sides.

Step 3.12 Secure wheel assembly with two 1/2" screws in kit KA 0150 through the pre-drilled holes in the lead edge into each wheel assembly.

Step 3.13 Flip the lead edge back over and secure the cover with two 1/2" screws, found in kit KA 0150, through the pre-drilled holes in the lead edge channel on both sides. The holes should be centered between the stitched corners of the cover.

Step 3.14 Grasp the rope handles and pull the cover closed. If alone, attach the center rope to the existing 2 handles by using the tack hooks to pull the cover closed.

Step 3.9 & 10

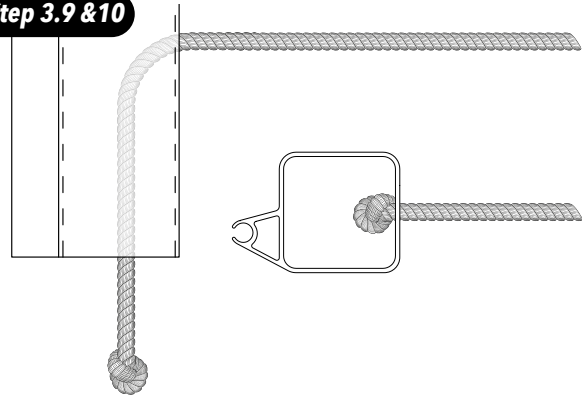

Step 3.11 & 12

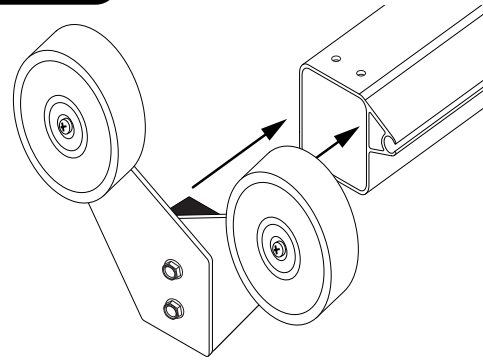

Step 3.13

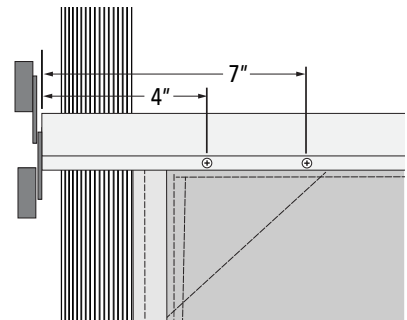

Step 3.14

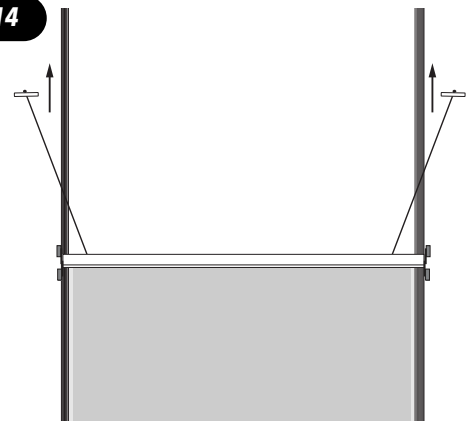

STEP 4: INSTALLING THE MECHANISM

INSTRUCTIONS

Step 4.1 Locate the kit that contains the A-frame and components for the Manual Guard unit.

Step 4.2 Assemble the tube, A-frame and cranks with the hardware provided by following the instructions inside the box. Make sure to position the hand cranks 180 degrees from each other.

HINT: By applying a marine grade lubricant (not provided) to both the inside and outside of the black bushing may help during operation.

Step 4.3 Place the assembled unit into place, 1" behind the track, and center unit with the tracks.

Step 4.4 Use a 3/8" masonry bit and drill into the deck 3" deep through the base of the A-frame on each side and secure them with the 3/8" edge anchors found in kit KA 0150 and tighten down the nuts until the washer meets the A-frame base.

Step 4.5 Position the tail end of the cover under the tube and attach the cover to the tube accordingly to the diagram provided with 1/2" screws found in kit KA 0150.

Step 4.6 Use the handles to open the cover.

NOTE: Place the pull rope and handles on the front of the cover when opening.

Make sure to put the cover pump on top of the cover when it is in the closed position and not being used.

Step 4.2

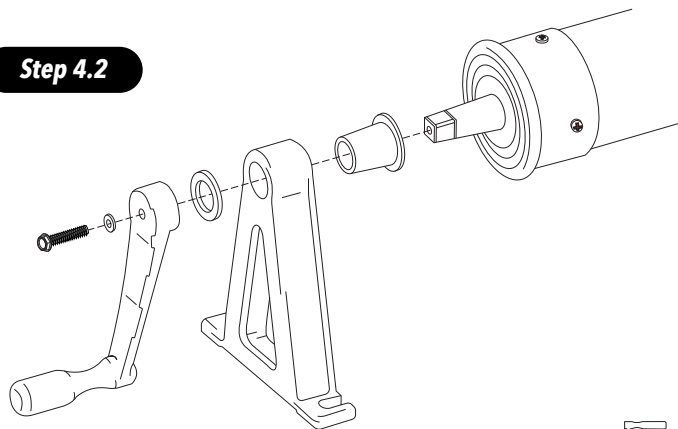

Step 4.3

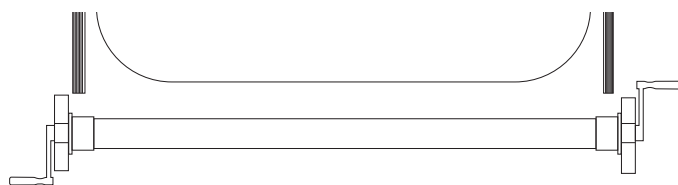

Step 4.4

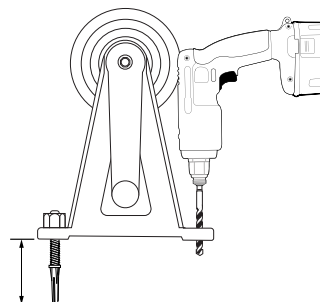

Step 4.5

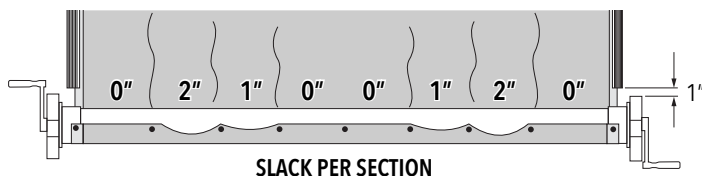

TECHNICAL SUPPORT

If you have any questions about these installation procedures, please contact Technical Support (800) 878-5789 Monday through Friday, 8 am - 5 pm EST.

Automatic Pool Covers, Inc.

(800) 878-5789 • automaticpoolcovers.com

FLUSH TRACK Installation Instructions

TOOLS NEEDED

- | | | | |
|----------------------------------|--|--------------------------------------|-----------------------------|
| 1. Cordless drill | 2. Hammer drill | 3. Flat-head & Phillips screwdrivers | 4. Hammer |
| 5. Hacksaw with 18 tooth blade | 6. 12" Torpedo level | 7. 1/2" Round bastard file | 8. Wire strippers w/cutters |
| 9. Saw (with aluminum blade) | 10. 25' & 100' tape measures | 11. 100' string | 12. Flat shovel |
| 13. Box knife | 14. Scissors | 15. Extension cords | 16. Countersink |
| 17. Wrenches: 7/16", 1/2", 9/16" | 18. Drill bits: 1/4", 5/32", 11/64" | 19. Driver bits: #2 & #3 Phillips | 20. 5/16" nut driver |
| 21. Socket driver: 7/16" | 22. Masonry bits: 1/4" x 4" & 6" & 1/2" x 4" | | |

STEP 1: INSTALLING THE MECHANISM

INSTRUCTIONS

Install the Motor Control panel following the Wiring Diagram enclosed with Motor.

Step 1.1 Verify the track space that was ordered for your system. This can be found on all of the packing slips. **Ex. T/W [FT] 20.25 T/L [FT] 43**
The mechanism, main tube, lead edge and cover are based off the ordered track space.

Step 1.2 Attach the main tube to the mechanism end and opposite end castings with four 5/16"-18 x 0.75" bolts and lock washers found in kit KA0183, using a 1/2" wrench.

Step 1.3 Measure the distance between the two tracks and find the halfway point and mark it on the front of the recessed housing.

Step 1.4 If using an APC, Inc. polymer box, install both channel plates for mechanism end and opposite end found in kit KA0326. Install drop in brackets using 2-3/8"-16 x 0.75" bolts, found in a heat sealed packaged in the small kit box. Leave brackets loose so you will be able to center the unit from left to right. **NOTE: Make sure to use the holes marked "TT".**

Step 1.5 Set the unit into the recessed housing and align the center mark of the tube to the mark that you placed on the front of the recessed housing.

Step 1.6 Starting at the mechanism end, secure the mounting brackets to the recessed housing using the appropriate hardware.
Wood housing: Lag bolts, found in kit KA0045
Concrete housing: track screws/red anchors, found in kit KA0044
APC, Inc. polymer box: 3/8"-16 x 1.25" bolts in a heat sealed package

Step 1.7 Repeat the process on the opposite side.

FOOT DECIMAL TO INCH CONVERSION

Decimal	.08	.17	.25	.33	.42	.50	.58	.67	.75	.83	.92
Inches	1	2	3	4	5	6	7	8	9	10	11

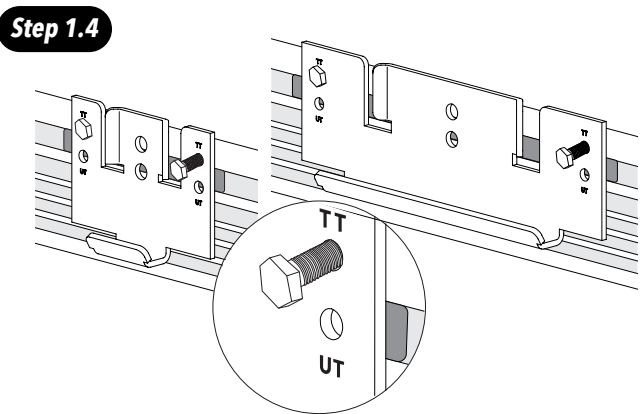
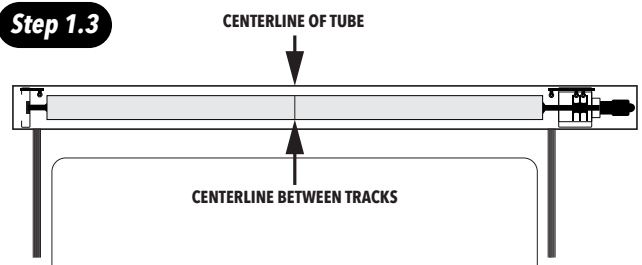
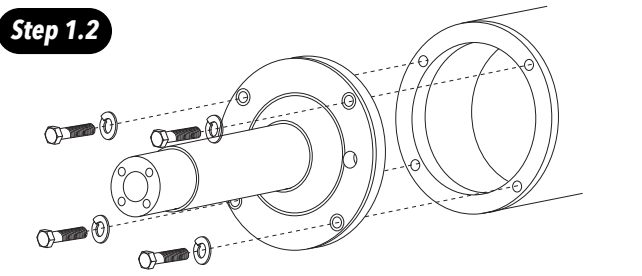

INSTRUCTIONS (CONTINUED)

Pro's Tip

Use the rope angle to dictate how high to mount the mechanism and opposite end. Typically, the top of the mechanism brackets is mounted $\frac{1}{2}$ " from the top of the recessed housing. The rope should come straight out of the track into the pulley assembly, while maintaining a slight downward angle. (This does not apply if using an APC, Inc. polymer box.)

Step 1.8

When system is secured, level and center unit from front to back and left to right. Tightened all hardware on the mechanism with a $\frac{1}{2}$ " wrench. If system is mounted in an APC, Inc. polymer box, make sure to secure all of the $\frac{3}{8}$ "-16 with a $\frac{9}{16}$ " socket and ratchet.

Step 1.9

Locate two eyelets found in kit KA0183, install on the backside of the recessed housing at least 4' from each end of the track. Make sure that the eyelets are in line with the pulleys on the mechanism end and opposite end mounting brackets.

Step 1.10

Layout the lid bracket sleeves found in the small kit box and space them out accordingly. The spacing should be 1' from the track on the outer lid bracket sleeves and then space the remaining lid bracket sleeves equally.

Step 1.11

Secure the lid bracket sleeves $\frac{1}{4}$ " down from the top of the recessed housing with supplied hardware.

Wood housing: Lag bolts located in kit KA0045

Concrete housing: Track screws/red anchors located in KA0044

APC, Inc. polymer box: insert the channel plates, and secure them with 2- $\frac{3}{8}$ "-16 x 1.00" bolts.

Step 1.9

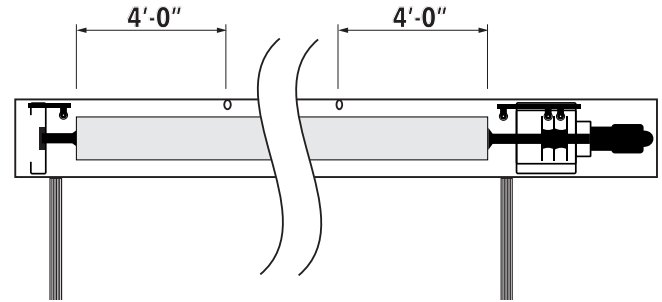

Step 1.10

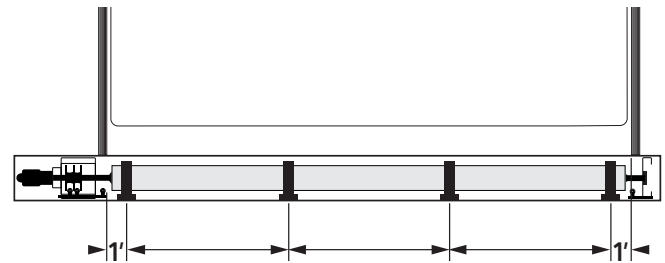

STEP 2: INSTALLING THE COVER AND TRACK

INSTRUCTIONS

Step 2.1 Layout the tracks on one side of the pool and insert the track splice and end pulley assembly found in kit KA0020.

Step 2.2 Insert the tracks into the U-channel and push the end pulley assembly all the way to the end.

Step 2.3 Cut off any excess track with a hacksaw or circular saw at the recessed housing end. Make sure all ends of the tracks are filed and countersunk.

Step 2.4 Repeat for the other side.

NOTE: If the track length is over 44', splice a third piece of track per side. Never install a piece of track less than 5'. If needed, cut one of the full pieces of track down to accommodate the extra.

Step 2.5 If the manufactured holes are cut off, drill new holes 3" from the splice end. Use a 1/4" drill bit and countersink. File and countersink all ends of the tracks for both sides to make sure there are no sharp edges to rub on the rope or webbing.

Step 2.6 Place the track onto the deck outside of the U-channel.

Step 2.7 Move the wrapped cover to the left side of the system. To allow the cover to unroll properly, position wrapped cover so the label is facing the pool water, and carefully remove the wrap.

NOTE: Make sure the matte side (smooth side) of the cover is facing upward showing the warning label.

Step 2.8 Carefully unwind the ropes making sure they do not get tangled.

Pro's Tip Insert the guide, located in kit KA0020, to help the rope stay in the track channel and not pop out. Keep a foot on top of the track, to keep it from moving while you pull the rope through.

Step 2.9 Starting on one side, with a 3' leader, snap the rope into the front channel (open) of the track and pull the rope down to the end pulley. Feed the rope around the end pulley, down the back channel (closed) of the track, while maintaining a 3' leader.

Step 2.10 Repeat for the other side.

Step 2.1

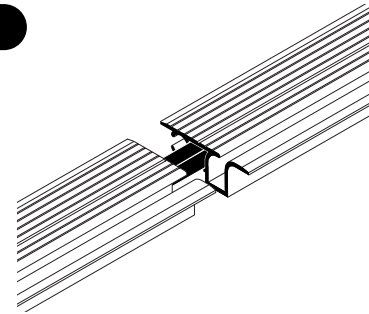

Step 2.2

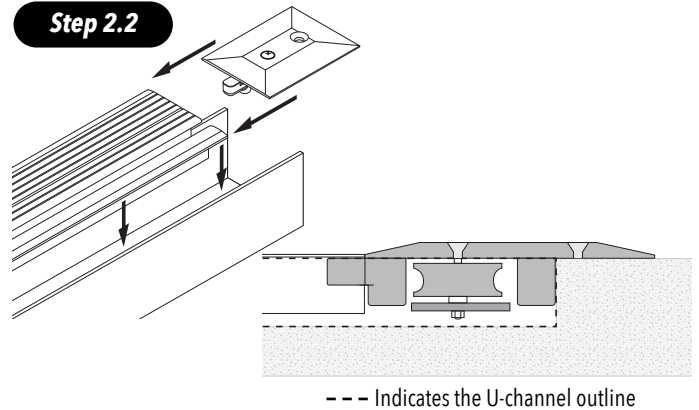

Step 2.5

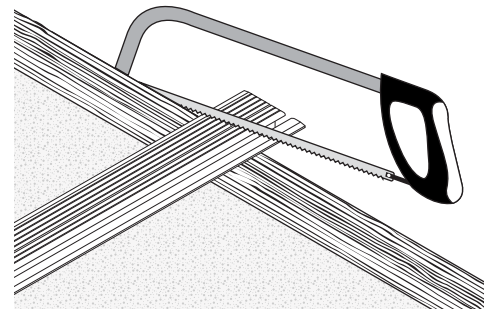

Step 2.9

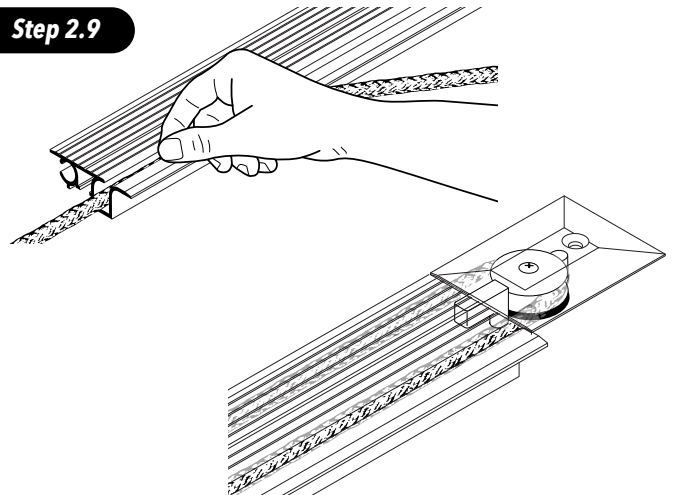

INSTRUCTIONS (CONTINUED)

Step 2.11 Route the opposite side rope through the opposite end pulley across the back of the box through the eyelets and through all 3 pulleys on the mechanism end and leave the extra length of rope lying on the deck.

Step 2.12 Route the motor side rope through the first 2 pulleys on the mechanism end and leave the extra length of rope lying on the deck.

Step 2.13 Insert the track into the U-channel making sure the end pulley assembly is pushed all the way to the end and the track splices are butted together.

Step 2.14 Use a 1/4" drill bit and drill through the pre-drilled holes in the track and into the U-channel. Do not drill into the concrete.

Step 2.15 Use a 1/4" masonry bit and drill 2" into the concrete below the U-channel.

Step 2.16 Locate kit KA0021 and insert each track screw into the red anchors by twisting the track screw into the red anchor.

Step 2.17 Install the track screws and anchors by tapping it through the track into the deck so that the top of the screw is 1/4" above the track.

Step 2.18 Make sure the tracks on both sides are butted together at the splice and secure all of the track screws using a #3 bit.

Pro's Tip To ensure the end pulley assembly will remain as flush as possible to the deck, drill a 1/4" hole through the end pulley assembly and secure it with a track screw and anchor.

NOTE: Make sure not to strip any of the screw heads, this will leave a sharp burr.

Step 2.11

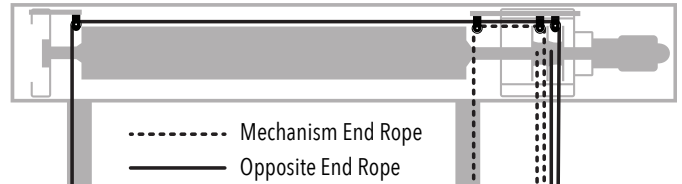

Step 2.13

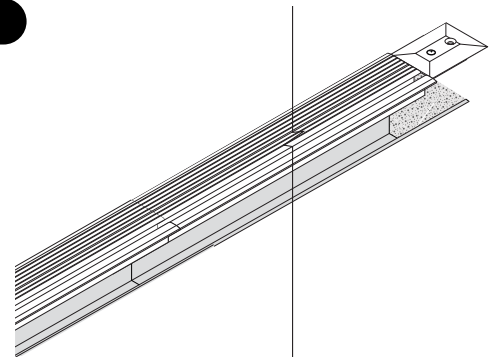

Step 2.14

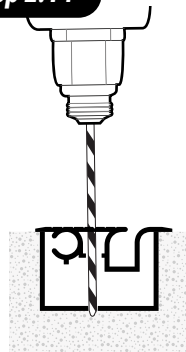

Step 2.15

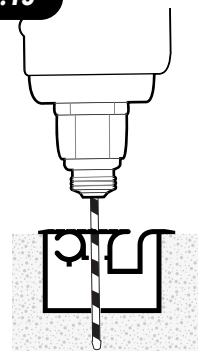

Step 2.17

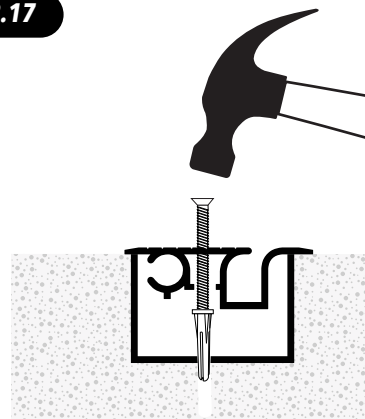

INSTRUCTIONS (CONTINUED)

Step 2.19 Starting on the opposite side, gently pull on the rope so the rope tabs slide in the track channel.

Step 2.20 Locate one of the rope sliders and four 5/16"-18 bolts in kit KA0187, and insert the bolts through the rope slider and rope tabs. Make sure the tabs on the bottom of the rope slider slips into the track channel.

Step 2.21 Find one of the carriage plates and four 5/16" nuts and lock washers in kit KA0187, install the carriage plate, squeezing the rope tabs in between the rope slider and carriage plate using the lock washers and nuts to secure all pieces. **DO NOT OVER TIGHTEN BOLTS.**

Step 2.22 Locate the lead edge bracket and carriage in kit KA0187, and slide the small end of the bracket through the slot in the carriage.

Step 2.23 Locate the track slider and two 1/4"- 20 flat head screws in kit KA0187, line up the holes of the track slider with the holes in the carriage and secure them with the flat head screws. This will contain the lead edge bracket with the carriage assembly.

Step 2.24 Join the carriage assembly with the rope/carriage plate and secure them together by using two 1/4"-20 bolts in kit KA0187. **DO NOT OVER TIGHTEN BOLTS.**

Step 2.25 Locate the bottom half of the guide in kit KA0020 and position the guide with the rope in one slot and the rope/webbing in the other slot. Slide the bottom half of the guide into the center channel of the track.

Step 2.26 Locate the top half of the guide in kit KA0020 and position it on the bottom half. Mark the center of the hole on the track.

Step 2.27 Remove the guide and drill a hole where the mark is on the track with a 1/4" drill bit.

Step 2.28 Reinsert the bottom half and top half of the guide to the track and secure the halves together with the button head screw through the guide and flat head screw through the track.

Step 2.25

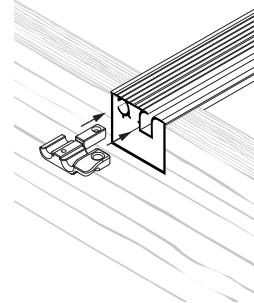

Step 2.26

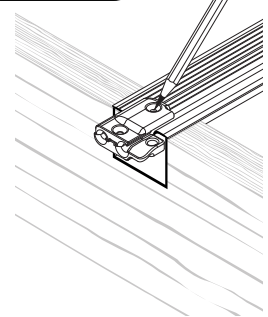

Step 2.27

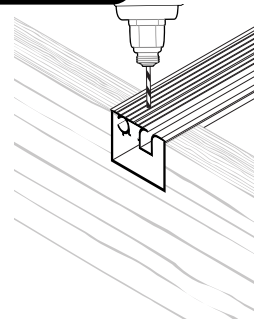

Step 2.28

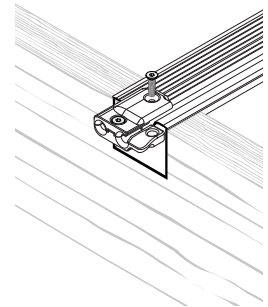

INSTRUCTIONS (CONTINUED)

Pro's Tip For a key switch system: install the open magnet, found in kit KA0184, into the front of the webbing on the motor side before you install the rope slider and carriage together. Pull the white strip off of the magnet and insert into the webbing. When positioning the magnets, take into consideration that the magnets will travel approximately 1" past the sensor before the cover stops.

Step 2.29 Locate the lead edge dowels in kit KA0187 and insert them into each end of the lead edge. Pre-drill an 11/64" hole through the lead edge and use the 1/2" screw to secure the dowels to the lead edge.

Step 2.30 Starting on the opposite side of the previously assembled carriage, slide the front edge of the fabric into the lead edge channel. Hold the fabric taut and slide the lead edge until it reaches the glider bracket.

Step 2.31 Insert the glider bracket into the middle slot of the lead edge dowel.

Step 2.32 Adjust the fabric corner in the lead edge and secure it with a 1/2" screw located in kit KA0183.

Step 2.33 Pull the fabric slack starting at the carriage side and work towards the opposite side. This will allow the slack to be even throughout the length of the lead edge.

Step 2.34 Adjust the fabric corner in the lead edge and secure it with a 1/2" screw, found in kit KA0183.

Step 2.35 Repeat steps 19 - 28.

NOTE: Make sure the lead edge brackets are in the same slots in the lead edge dowel on both ends.

Step 2.36 Gently pull the appropriate ropes to adjust the lead edge until it is parallel to the waters edge. When it is position correctly, cut the ropes evenly at 6' to 8' from the front edge of the recessed housing.

Step 2.37 Tie knots at each end of the rope and insert them into the appropriate side of the rope reel. Use the controller to operate the system in the "close" direction to help guide the excess rope onto the rope reel evenly. Be careful and make sure to remove your hands so they do not get wrapped up in the rope reel.

Step 2.38 Continue to close the cover until the lead edge reaches the end of the pool. The cover should feed into the track smoothly and evenly. If the cover catches at the guide, or if one side of the lead edge stops, release the controller and evaluate.

Step 2.29

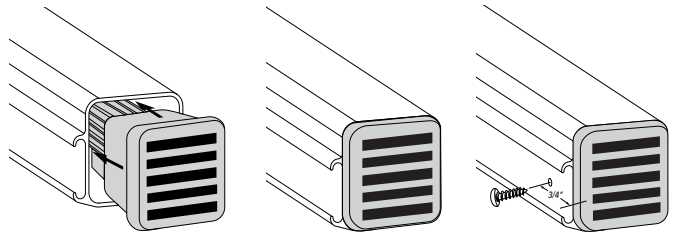

Step 2.30

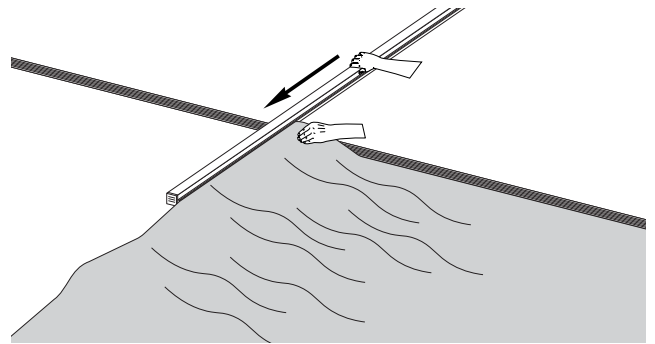

Step 2.36

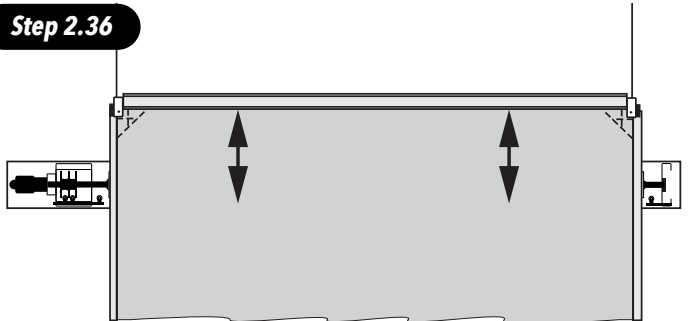

Step 2.37

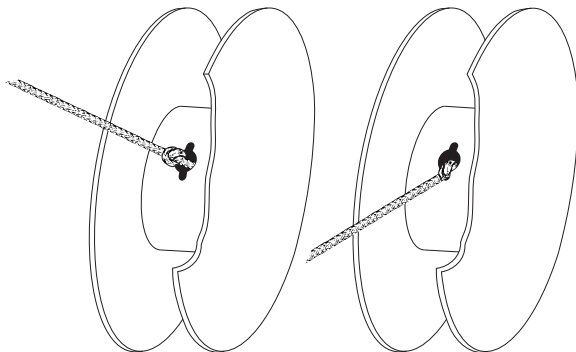

INSTRUCTIONS (CONTINUED)

Step 2.39 Attach the fabric to the drum with 1/2" screws found in kit KA0183. Make sure to align the edge of the webbing with the edge of the drum.

Step 2.40 Use the controller to open the cover enough to take up the extra length of fabric loosely around the drum. Cuff the edges of fabric at each end. If system is setup for a key switch, install the magnet, found in kit KA0184, in the tail end of the webbing on the motor side. Carefully cut a slit in the webbing 4" behind the guide. Pull the white strip off of the magnet and insert into the webbing. The magnets will travel approximately 1" past the sensor before the cover stops. Take this into consideration when installing the magnets.

Step 2.41 Open and close the cover 3 to 4 times to make sure the magnets are set properly (if applicable) and the cover is running square to the pool. If the cover is not square, adjust the cover as show.

Step 2.42 Locate four hard stops, eight #12 x 3.00" track screw and eight red red anchors in kit KA0187. Position one hard stop near the far end of the track and the other one near the recessed housing, at the magnet (if applicable), where you would like the lead edge bar to stop for both sides.

Step 2.43 Lay the stop so the notched end is flush with the front channel and the holes are at the center of the track. Mark the hole locations and drill the holes with a 1/4" drill bit. Drill into the U-channel and into the concrete.

Step 2.44 Insert each track screw into the red anchors. This is done by twisting the track screw into the red anchor.

Step 2.45 Insert each track screw/anchor by tapping it through the track so that the anchor is flush to the top of the concrete. Remove the track screw and line up the stop, insert the screw and secure with a #3 bit.

NOTE: Make sure not to strip any of the screw heads, this will leave a sharp burr.

Step 2.39

Slack Distribution

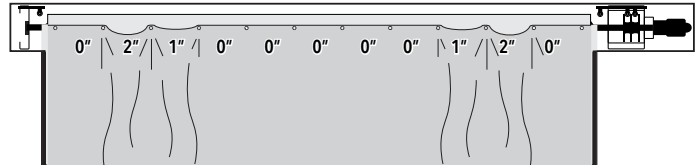

Step 2.43

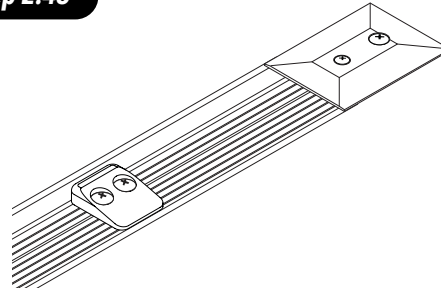

STEP 3: INSTALLING MAIN LID ASSEMBLY

INSTRUCTIONS

Step 3.1 Install the lid brackets found in the small kit box, into the lid bracket sleeves.

Step 3.2 Slide the lid hinge onto the standard aluminum main lid.

Step 3.3 Lay the lid assembly on top of the lid brackets centering the main lid between the tracks. Make sure there is equal distance on both sides of the track and that the lid assembly covers the front and back of the recessed housing. Cut any extra hinge with a hacksaw or circular saw making sure to leave approximately 1" of overhang on both ends of the housing. Make sure to file both ends of the hinge so there are no sharp edges or burrs.

NOTE: Cut the longer section of lid hinge if you have to use a 5' section of extra lid hinge.

Step 3.4 With the main lid assembly set in place, drill 1/4" holes through the lid hinge so the holes line up with the wood box (if applicable) starting 3" to 4" from each end of the hinge and then space the other holes every 4'.

Step 3.5 Secure the lid hinge with the appropriate supplied hardware:
Wood housing: Lid screws, found in kit KA0183
Concrete housing: lid screws/red anchors in kits KA0044 and KA0183

Step 3.6 Make sure the main lid is centered over the tracks and slide lid end on the motor side and mark it so it is even with the hinge. Cut the lid end with a jigsaw or circular saw and file both edges.

Step 3.7 Locate the correct lid triangle. Flip the lid end over and install the lid triangle by pre-drilling two 11/64" holes through the bottom of lid end and lid triangle.

Step 3.8 Secure the lid triangle using 1/2" screws found in kit KA0183.

Step 3.9 Install the remaining portion of the lid end and slide it on the opposite side and mark it so it is even with the hinge. Cut the lid end with a jigsaw or circular saw and file both edges.

Pro's Tip Cut the outside edge of the lid end to keep the manufactured cuts of the lid and lid end together.

NOTE: Double check to make sure the lid hinge, lid ends and main lid are filed thoroughly and do not have any sharp edges.

Make sure to put the cover pump on top of the cover when it is in the closed position and not being used.

Step 3.2

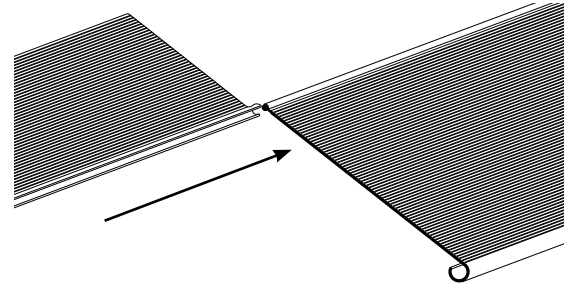

Step 3.4



Step 3.6

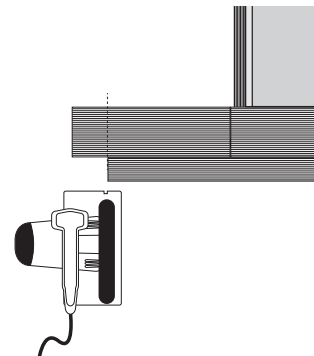

Step 3.9

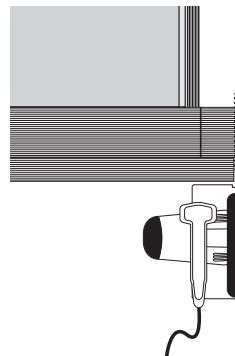

TECHNICAL SUPPORT

If you have any questions about these installation procedures, please contact Technical Support (800) 878-5789 Monday through Friday, 8 am - 5 pm EST.

Automatic Pool Covers, Inc.

(800) 878-5789 • automaticpoolcovers.com

TOOLS NEEDED

- | | | | |
|----------------------------------|-------------------------------------|--|-----------------------------|
| 1. Cordless drill | 2. Hammer drill | 3. Flat-head & Phillips screwdrivers | 4. Hammer |
| 5. Hacksaw with 18 tooth blade | 6. 12" Torpedo level | 7. 1/2" Round bastard file | 8. Wire strippers w/cutters |
| 9. Saw (with aluminum blade) | 10. 25' & 100' tape measures | 11. 100' string | 12. Flat shovel |
| 13. Box knife | 14. Scissors | 15. Extension cords | 16. Countersink |
| 17. Wrenches: 7/16", 1/2", 9/16" | 18. Drill bits: 1/4", 5/32", 11/64" | 19. Driver bits: #2 & #3 Phillips | 20. 5/16" nut driver |
| 21. Lighter | 22. Socket driver: 7/16" | 23. Masonry bits: 1/4" x 4" & 6" & 1/2" x 4" | |

STEP 1: LAYING OUT THE TRACK

INSTRUCTIONS

Step 1.1 Verify the track space that was ordered for your system. This can be found on all of the packing slips. **Ex. T/W [FT] 20.25 T/L [FT] 43**
The mechanism, main tube, lead edge and cover are based off the ordered track space.

Step 1.2 Determine **TRACK LENGTH**: Measure from the inside front of the recessed housing to the opposite end of the pool and add 2' for overlap.

Step 1.3 Lay the tracks out on one side of the pool, insert a track splice, found in kit KA 0178 and cut off any excess track with a hacksaw or circular saw at the recessed housing end. **Make sure to file and countersink all ends of the tracks.**

HINT: Do not cut the track where the splices will meet. It is best to keep the manufactured cuts at the splice.

NOTE: If the track length is over 44', splice a third piece of track per side. Never install a piece of track less than 5'. If needed, cut one of the full pieces of track down to accommodate the extra.

Step 1.4 If, after cutting, the manufactured holes are cut off, drill new holes 3" from the splice end. Use a 1/4" drill bit and countersink. File and countersink all ends of the tracks to make sure there are no sharp edges for the rope or webbing to rub on.

Step 1.5 Align the tracks with the inside edge of the recessed housing on both sides and measure the distance between the tracks. **This is the edge to edge measurement. Add 1" for your track width.**

Step 1.6 Place the tracks equal distance from each side of the pool. The track space needs to be the same at the recessed housing, the splice and the opposite end to make sure they are parallel.

Step 1.7 To insure the layout is square, take a diagonal measurement and adjust accordingly.

FOOT DECIMAL TO INCH CONVERSION

Decimal	.08	.17	.25	.33	.42	.50	.58	.67	.75	.83	.92
Inches	1	2	3	4	5	6	7	8	9	10	11

Step 1.2 & 1.5

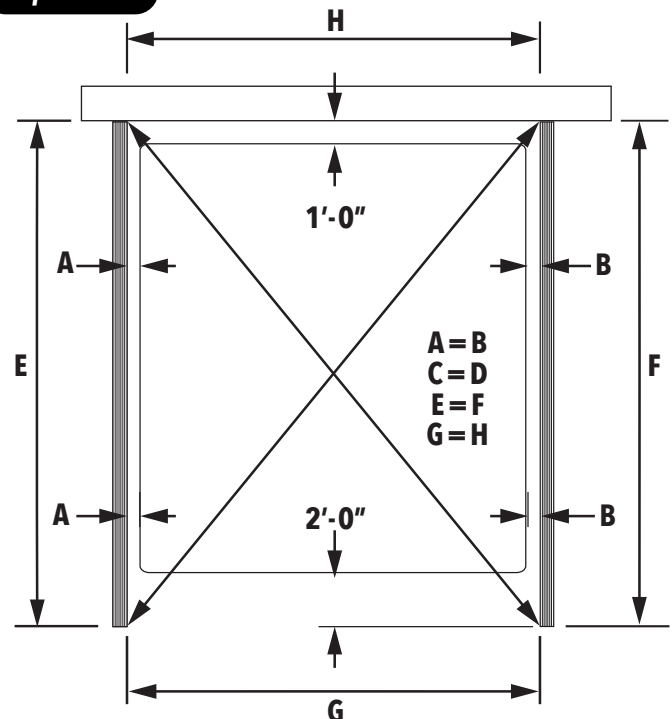

Step 1.3

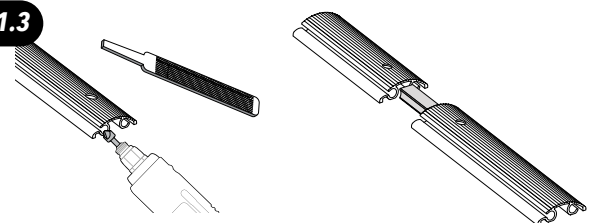

STEP 2: INSTALLING THE TRACK

INSTRUCTIONS

Step 2.1 Locate kit KA 0006 and insert each track screw into the red anchors by twisting the track screw into the red anchor.

Step 2.2 Starting at the unit end, use a hammer drill with a 1/4" masonry bit and drill through the closest hole 3" deep.

Step 2.3 Install a track screw and anchor by tapping it through the track into the deck. **Do not tighten down the track screw at this time.**

Step 2.4 Make sure the track splice is snug together and walk down to the opposite end and drill the last hole 3" deep.

Step 2.5 Install one of the track screws and anchors by tapping it through the track into the deck. **Do not tighten down the track screw at this time.**

HINT: Stand on the track while drilling to prevent the track from shifting.

Step 2.6 To keep the track straight, run a string down the track from one end to the other by using the track screws installed, allowing the rest of the holes in the tracks to line up.

Step 2.7 Drill the remaining holes and insert the track screws and anchors. **Do not tighten down.**

Step 2.8 Repeat steps for the opposite side.

NOTE: An angle drill may needed to drill holes under a slide.

Step 2.9 When all the tracks are drilled and loosely secured with the track screws and anchors, find the pulley casting assembly in kit KA 0178 and insert the pulley casting assembly on the far end of the pool.

Step 2.10 Tap the top of the pulley casting to create a mark in the concrete deck.

Step 2.11 Remove the pulley casting and drill a 1/2" diameter hole 1/2" deep on the mark. This allows the pulley nut to recess into the deck.

Step 2.12 Repeat the steps for the opposite side.

Step 2.2

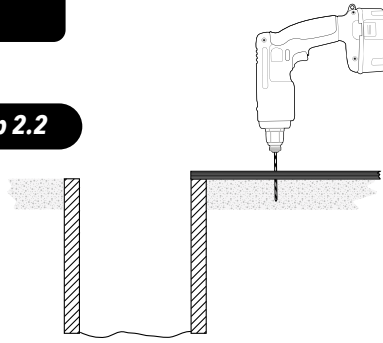

Step 2.3

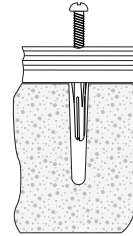

Step 2.4



Step 2.5

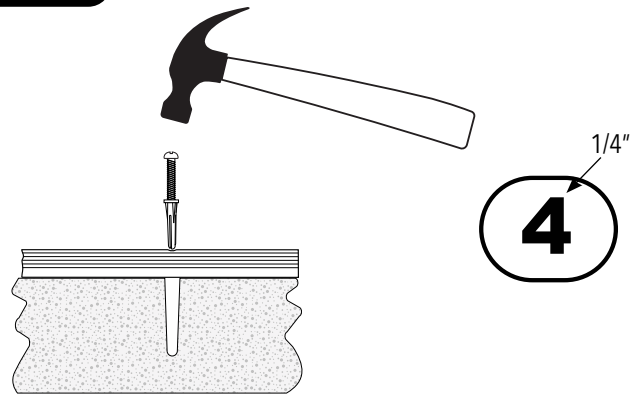

Step 2.10



Step 2.11

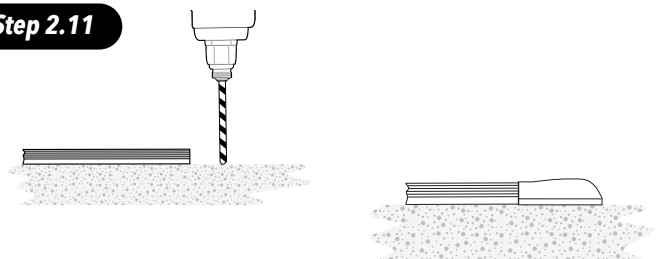

STEP 3: INSTALLING AUTO GUARD SYSTEM

INSTRUCTIONS

Install the Motor and Control panel following the Wiring Diagram enclosed with Motor.

Step 3.1 Attach the main tube to the mechanism end and opposite end castings with 4 bolts and lock washers found in kit KA 0183 with a 1/2" wrench.

Step 3.2 Measure the distance between the two tracks and find the halfway point and mark it on the front of the recessed housing.

Step 3.3 Set the unit into the recessed housing and align the center mark of the tube with the mark made on the front of the recessed housing.

Step 3.4 When the system is secured, make sure the unit is leveled and centered from front to back and left to right. Tighten all of the hardware on the mechanism with a 1/2" wrench.

Step 3.5 Starting at the mechanism end, secure the mounting brackets to the recessed housing using the appropriate hardware. Lag bolts for wood housing, found in kit KA 0045, track screws/red anchors for concrete housing, found in kit KA 0044.

Tip: Usually the top of the mechanism brackets is mounted 1/4" from the top of the recessed housing. Use the rope angle to dictate how high to mount the mechanism and opposite end. The rope should come straight out of the back channel of the track into the pulley assembly, while maintaining a slight downward angle. This does not apply if using an APC, Inc. polymer box.

Step 3.6 Install two eyelets found in kit KA 0183 on the backside of the recessed housing at least 4' from each end of the track. Make sure the eyelets are inline with the pulleys on the mechanism end and opposite end mounting brackets.

Step 3.7 Layout the lid bracket sleeves and space them out accordingly. The spacing should be 1' from the track on the outer lid bracket sleeves and the remaining lid bracket sleeves spaced equally.

Step 3.8 Secure the lid bracket sleeves 1/4" down from the top of the recessed housing with supplied hardware. Lag bolts for wood housing located in kit KA 0045, track screws/red anchors for a concrete housing located in KA 0044, or use 1/4" x 3" wedge anchors.

Step 3.1

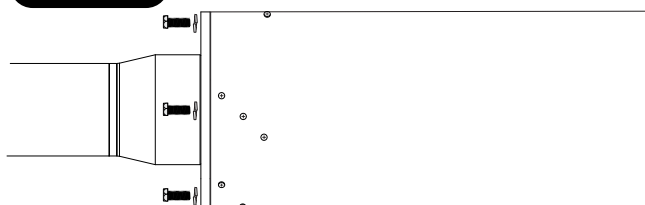

Step 3.2

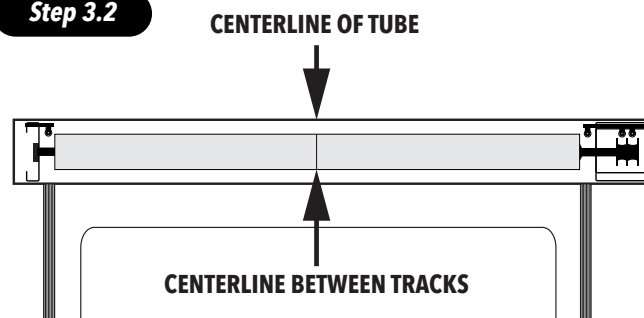

Step 3.6

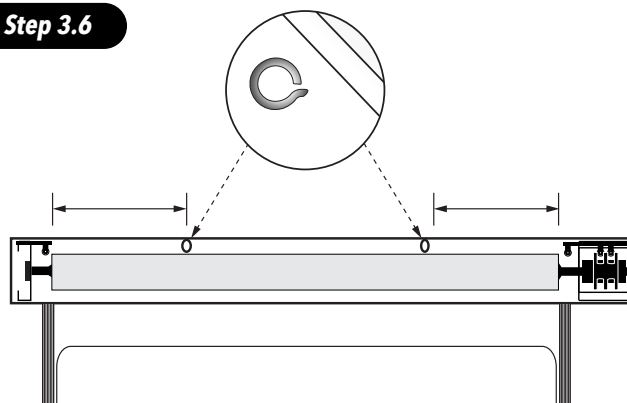

Step 3.7

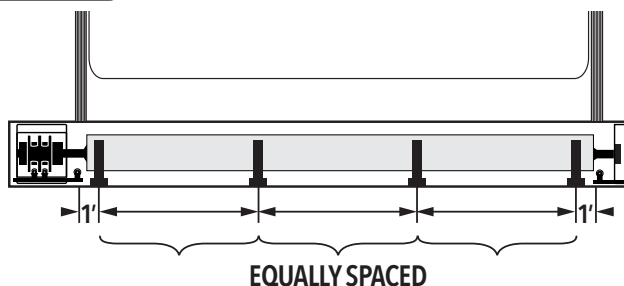

STEP 4: COVER INSTALLATION

INSTRUCTIONS

Step 4.1 Lay the cover to the left side of the system and carefully remove the wrap. To allow the cover to unroll properly, be sure the label is facing the pool water.

NOTE: Make sure the matte side (smooth side) of the cover is facing upward showing the warning label.

Step 4.2 Carefully unwind the ropes making sure they do not get tangled.

Step 4.3 Starting on one side, with a 3' leader, snap the rope into the front channel (open) of the track and pull the rope down to the end pulley. Feed the rope around the end pulley, down the back channel (closed) of the track, while maintaining a 3' leader. Repeat for the other side.

TIP: Inserting the guide, found in kit KA 0178, will help keep the rope in the track channel and keep it from popping out.

Step 4.4 Feed the opposite side rope through the opposite end pulley across the back of the box through the eyelets and through all 3 pulleys on the mechanism end and leave the extra length of rope lying on the deck.

Step 4.5 Feed the motor side rope through the first 2 pulleys on the mechanism end and leave the extra length of rope lying on the deck.

Step 4.6 Make sure the tracks on both sides are butted together at the splice and secure all of the track screws using a #3 bit.

NOTE: Make sure to not strip any of the screw heads, because this will leave a sharp burr.

Step 4.7 Starting on the opposite side, gently pull on the rope so the rope tabs slide in the track channel.

Step 4.8 Locate one of the rope sliders and (4) 5/16"-18 bolts in kit KA 0185, and insert the bolts through the rope slider and rope tabs. Make sure the tabs on the bottom of the rope slider slips into the track channel.

Step 4.9 Locate one of the carriage plates and (4) 5/16" nuts and lock washers in kit KA 0185, install the carriage plate, squeezing the rope tabs in between the rope slider and carriage plate using the lock washers and nuts to secure. **Do not over tighten bolts.**

Step 4.10 Locate the lead edge bracket and carriage in kit KA 0185 and slide the small end of the bracket through the slot in the carriage.

Step 4.11 Locate the track slider and (2) 1/4"-20 flat head screws in kit KA 0185. Line up the holes of the track slider with the holes in the carriage and secure with the flat head screws. This will contain the lead edge bracket with the carriage assembly.

Step 4.3

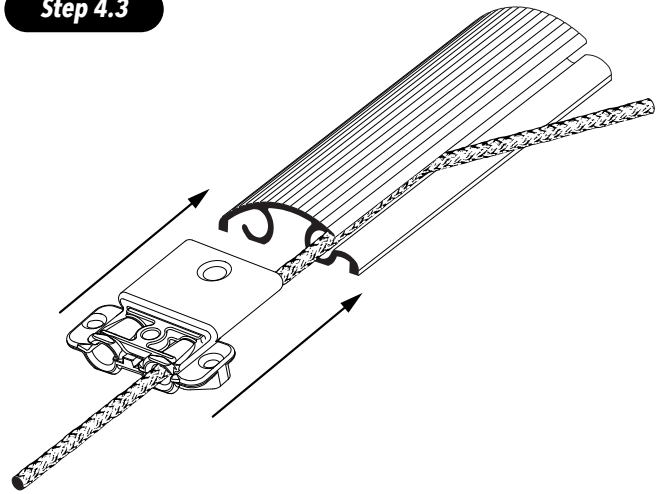

Step 4.4



INSTRUCTIONS (CONTINUED)

Step 4.12 Now join the carriage assembly with the rope/carriage plate and secure together using (2) 1/4"-20 bolts in kit KA 0185. **Do not over tighten bolts.**

Step 4.13 Locate the bottom half of the guide in kit KA 0178 and position the guide with the rope in one slot and the rope/webbing in the other slot. Slide the bottom half of the guide into the center channel of the track.

Step 4.14 Locate the top half of the guide in kit KA 0178 and position it on the bottom half. Mark the center of the hole on the track.

Step 4.15 Remove the guide and drill a hole at the mark on the track with a 5/16" drill bit.

Step 4.16 Reinsert the bottom half and top half of the guide to the track and secure the halves together with the button head screw through the guide and flat head screw through the track.

Step 4.17 Repeat steps 3-11 for the other side.

TIP: If your system is setup for a key switch, install the open magnet, found in kit KA 0184, into the front of the webbing on the motor side before installing the rope slider and carriage together. Pull the white strip off of the magnet and insert into the webbing. The magnets will travel approximately 1" past the sensor before the cover stops. Take this into consideration when installing the magnets.

Step 4.18 Find the lead edge dowel in kit KA 0185 and insert into each end of the lead edge. Pre-drill an 11/64" hole through the lead edge and use the 1/2" screw to secure the dowels to the lead edge.

Step 4.19 Starting on the motor side, slide the front edge of the cover into the lead edge channel. Hold the cover taut and slide the lead edge until it reaches the glider bracket. Insert the glider bracket into the middle slot of the lead edge dowel.

Step 4.20 Adjust the cover corner in the lead edge and secure it with a 1/2" screw located in kit KA 0183 (found in the small kit box.)

Step 4.21 With lead edge screw in place, starting at the opposite end pull cover slack and work towards the motor side. This will allow the slack to be even throughout the length of the lead edge.

Step 4.22 Adjust the cover corner in the lead edge and secure it with a 1/2" screw found in kit KA 0183.

Step 4.23 Repeat steps 4.12 - 4.16 on opposite end.

NOTE: Make sure the lead edge brackets are in the same slots of the lead edge dowel.

Step 4.19

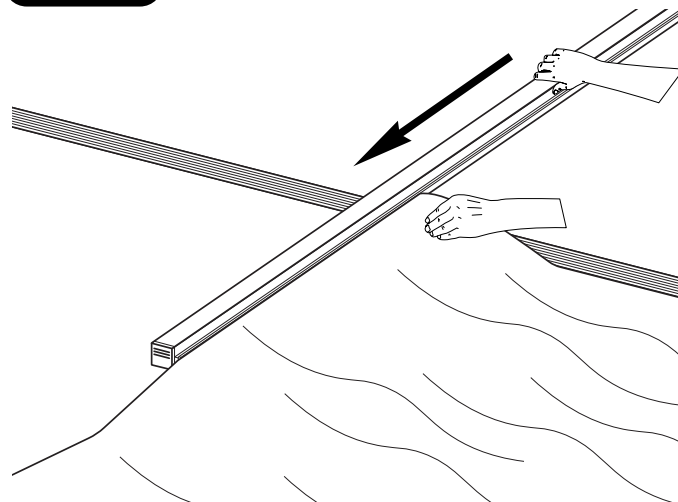

INSTRUCTIONS (CONTINUED)

Step 4.24 Adjust the lead edge until it is parallel to the pool edge by gently pulling on the appropriate ropes. When satisfied with the position, cut the ropes evenly at 6' from the front edge of the recessed housing.

Step 4.25 Melt end of rope with a lighter and round the melted tip. On the inside of the appropriate reel, feed the end of the rope through the first hole, and back into the second. Repeat for the other rope, using the remaining holes.

Step 4.26 Use the controller to operate the system in the "close" direction to help guide the rope onto the rope reels evenly. **CAUTION: Keep hands clear so they do not get wrapped up in the rope reel.**

Step 4.27 Continue to close the cover until the lead edge reaches the end of the pool. The cover should feed into the track smoothly and evenly. If the cover catches at the guide or if one side of the lead edge stops, release the controller and evaluate.

Step 4.28 Attach the cover to the tube according to the diagram provided with 1/2" screws found in kit KA 0183. **Make sure to align the edge of the webbing with the edge of the tube.**

Step 4.29 Use the controller to open the cover enough to take up the extra length of cover loosely around the tube. Cuff the edges of cover at each end. **If system is setup for a key switch, install the close magnet, found in kit KA 0184, in the tail end of the webbing on the motor side. Carefully cut a slit in the webbing 6" behind the guide. Pull the white strip off of the magnet and insert into the webbing. The magnets will travel about 1" past the sensor before the cover stops. Take this into consideration when installing the magnets.**

Step 4.30 Run the cover 3 to 4 times open and close to ensure the magnets are set properly (if applicable) and the cover is running square to the pool. If not, follow the diagrams below on how to adjust the cover.

Step 4.31 Find 4 hard stops, (8) #12 x 3.00" track screw and (8) red anchors in kit KA 0185. Position one hard stop near the far end of the track and the other one near the recessed housing at desired location for the lead edge bar to stop for both sides.

Step 4.32 Lay the stop so the thicker end is flush with the front channel and the holes are at the center of the track. Mark the hole locations and drill the holes with a 1/4" drill bit.

Step 4.33 Use a 1/4" masonry bit and drill 3" deep.

Step 4.34 Insert each track screw into the red anchors by twisting the track screw into the red anchor.

Step 4.35 Insert each track screw/anchor by tapping it through the hard stop and track so that the screw is 1/4" off the track. Secure with a #3 bit.

NOTE: Make sure that you do not strip any of the screw heads as this will leave a sharp burr.

Step 4.25

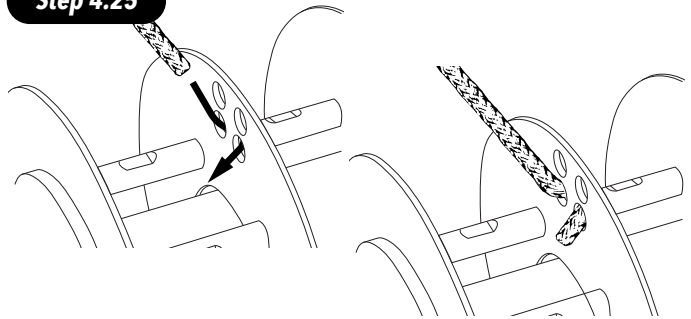

Step 4.28

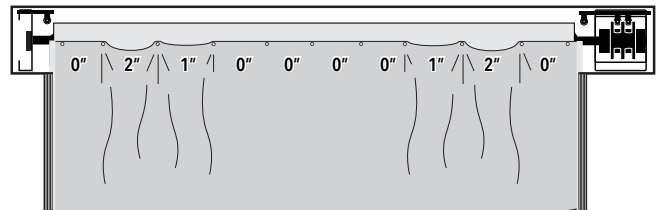

Step 4.29

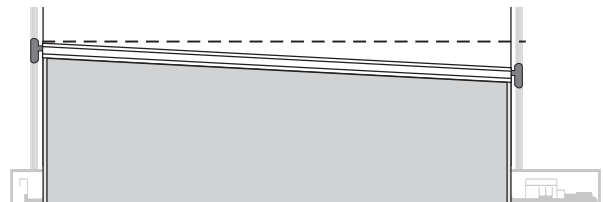

The **RIGHT** side rope need to be adjusted. Take all rope off the rope reel. **SHORTEN** the rope for this side by adjusting the location of the knot that is inserted into the rope reel approximately the same distance that the cover is crooked. Place rope back onto the reel and close cover.

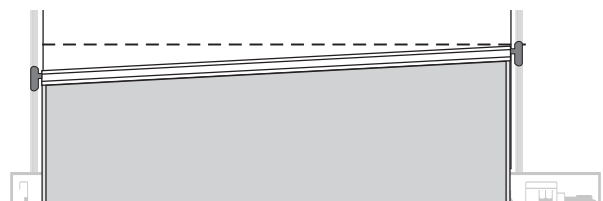

The **LEFT** side rope need to be adjusted. Take all rope off the rope reel. **SHORTEN** the rope for this side by adjusting the location of the knot that is inserted into the rope reel approximately the same distance that the cover is crooked. Place rope back onto the reel and close cover.

STEP 5: INSTALLING STANDARD MAIN LID

INSTRUCTIONS

- Step 5.1** Install the lid brackets into the lid bracket sleeves.
- Step 5.2** Slide the lid hinge onto the standard aluminum main lid.
- Step 5.3** Lay the lid assembly on top of the lid brackets centering the main lid between the tracks. Make sure there is equal distance on both sides of the track and that the lid assembly covers the front and back of the recessed housing. Cut any extra hinge with a hacksaw or circular saw making sure to leave approximately 1" of overhang on both ends of the housing. Make sure to file both ends of the hinge so there are no sharp edges or burrs.

NOTE: It is best to cut the longer section of lid hinge if you have to use a 5' section of extra lid hinge.

- Step 5.4** With main lid assembly set in place, drill 1/4" holes through the lid hinge lining up holes with the wood box (if applicable) starting 3"-4" from each end of the hinge and space the other holes every 4'.
- Step 5.5** Secure the lid hinge with the supplied hardware. Lid screws for a wood housing found in kit KA 0183 or lid screws/red anchors for a concrete housing in kits KA 0044 and KA 0183.

- Step 5.6** Make sure the main lid is centered over the tracks. Measure for the mechanism end lid end and opposite end lid end.

TIP: Make sure that the cut end of the lid end is closest to the main lid. This allows lid triangles to be secured and to hide any imperfection in cuts.

- Step 5.7** Locate the correct lid triangle for both sides. Flip the lid end over and install the lid triangle by pre-drilling two 11/64" holes through the bottom of lid end and lid triangle.
- Step 5.8** Secure the lid triangle using 1/2" screws found in kit KA 0183.

NOTE: Double check to make sure the lid hinge, lid ends and main lid are filed thoroughly and do not have any sharp edges.

Make sure to put the cover pump on top of the cover when it is in the closed position and not being used.

Step 5.2

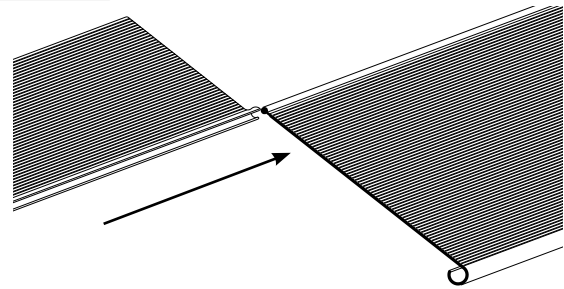

Step 5.4

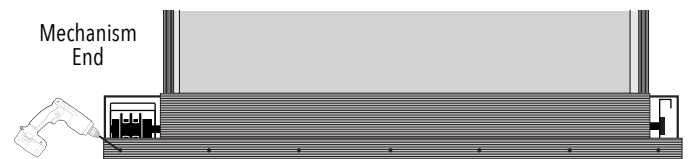

Step 5.6

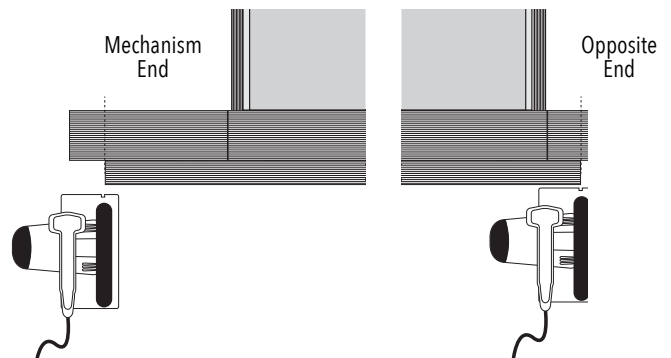

TECHNICAL SUPPORT

If you have any questions about these installation procedures, please contact Technical Support (800) 878-5789 Monday through Friday, 8 am - 5 pm EST.

Automatic Pool Covers^{Inc.}

(800) 878-5789 • automaticpoolcovers.com

REPLACEMENT COVER

Removal and Installation Instructions

IMPORTANT

Prior to removing old cover, measure track space and verify the track space that was ordered matches the track space listed on replacement cover label. This can be found on all of the packing slips. This is important because after the cover is removed and the pool is exposed, safety is compromised.

Ex. T/W [FT] 20.25 T/L [FT] 43

There are several different types of automatic pool cover systems and each system has some unique parts and characteristics. Although these instructions are based on the Automatic Pool Covers, Inc. product, most steps will apply to all of the cover systems.

FOOT DECIMAL TO INCH CONVERSION											
Decimal	.08	.17	.25	.33	.42	.50	.58	.67	.75	.83	.92
Inches	1	2	3	4	5	6	7	8	9	10	11

ATTENTION

Different styles of systems (Top Track, Under Track, etc.) and components (gliders, etc.) have subtle differences while installing covers. Instruction manuals for all these different variations are available with specific directions and illustrations. Please contact Technical Support (800) 878-5789 if you require these additional manuals.

REMOVING OLD COVER

1. Remove lid and lid brackets and place to the side of pool.
2. Open cover completely.
3. Disconnect ropes from reels and remove the track guides.
4. Remove the Lead Edge from fabric.
5. Pull cover out of track.
6. **Cut the ropes off of fabric KEEPING THE OLD ROPE IN THE TRACK.**
7. Remove and dispose of old cover.

PREPARATION FOR NEW COVER

1. Suggested items to be replaced
 - Pulleys
 - Guides
 - Gliders (if applicable)
 - Wheels (if applicable)
2. Check/Repair
 - Box walls - Secure if they are collapsing or pulling away from the surrounding pool deck
 - Tube - Re-drill for the fasteners if they have been stripped
3. Inspection points
 - Mechanism
 - Drive shaft - should be free of scale or other buildup of debris
 - Drive pin/clutch
 - Unit alignment - unit should be centered and level across entire width
 - Bearings - should be free of scale or debris and properly tensioned
 - Tracks - tighten/replace fasteners as needed
4. Clear the box of debris
 - Check track at end pulley for debris

INSTALLING NEW COVER

- Step 1** Unroll cover behind box from left to right with the packing slip facing the housing.
- Step 2** Uncoil ropes and pull new ropes through tracks or attach to old rope left in track and pull.
- Step 3** Insert front magnets (if required.)
- Step 4** Insert one corner of cover into track (with glider if applicable.)
- Step 5** Install lead edge and lead edge hardware (i.e. glider bodies.)
- Step 6** Insert remaining corner of cover into track and attach new guides and sensor (if equipped.)
- Step 7** Pull rope until Lead Edge is approximately 6" into track and straight to pool.
- Step 8** Run ropes through pulleys and cut ropes to length (6' - 8' past rope reel.)
- Step 9** Attach ropes to reel.
- Step 10** Close cover, watch to assure it feeds into track without catching.
- Step 11** Attach the cover to the tube, allowing the slack as shown, into the holes pre-drilled every 18". Make sure to align the edge of the webbing with the edge of the tube. It is important that the sections with 0" of slack be taut.
- Step 12** Use the controller to open the cover enough to take up the extra length of cover loosely around the tube. Cuff the edges of cover at each end.
- Step 13** Fold the fabric/webbing under itself at both ends of the drum.
- Step 14** Open cover completely and barring any issues, open and close 2 or 3 times.
- Step 15** Adjust as needed.
- Step 16** Re-install lid brackets and lid.

NOTE: Lid brackets may need bent during re-installation of lid. Bend brackets so lid is not rubbing or touching vinyl.

Step 11

Slack Distribution

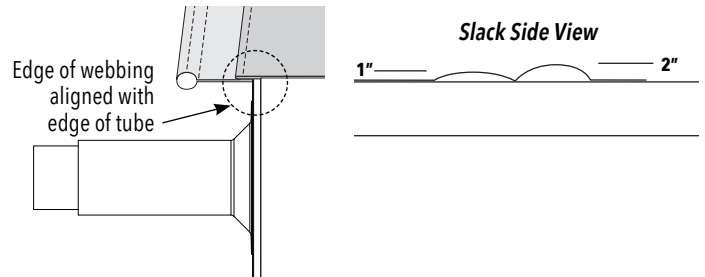
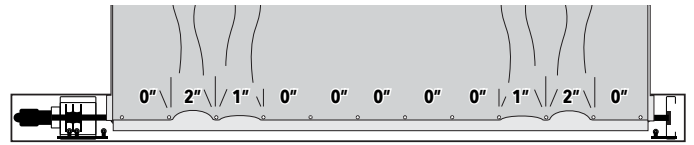

Step 15

If the cover opens crookedly, adjust the rope that corresponds to the side that is closest to the lid.

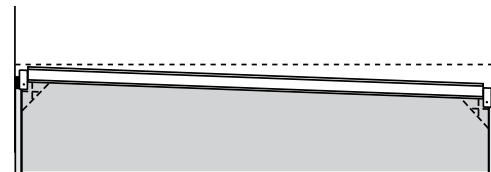

The **RIGHT** side rope need to be adjusted. Take all rope off the rope reel. **SHORTEN** the rope for this side by adjusting the location of the knot that is inserted into the rope reel approximately the same distance that the cover is crooked. Place rope back onto the reel and close cover.

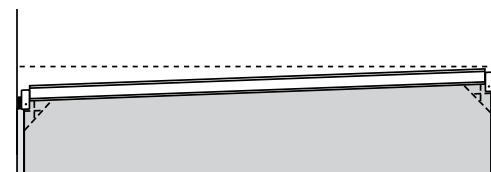

The **LEFT** side rope need to be adjusted. Take all rope off the rope reel. **SHORTEN** the rope for this side by adjusting the location of the knot that is inserted into the rope reel approximately the same distance that the cover is crooked. Place rope back onto the reel and close cover.

TECHNICAL SUPPORT

If you have any questions about these installation procedures, please contact Technical Support (800) 878-5789 Monday through Friday.

Automatic Pool Covers, Inc.

(800) 878-5789 • automaticpoolcovers.com